

LED-Pinball-Display 10101

Board Part Number / Platinenbauteilenummer 2003001 Rev.D

Schematics - Schaltpläne

© 2007 by PinLED

Contents - Inhalt

Page 3 / Seite 3.....	Strobes / Stellen.....	
Page 4 / Seite 4.....	Digits / Segments.....	Upper Row
Page 5 / Seite 5.....	Digits / Segmente.....	Upper Row
Page 6 / Seite 6.....	Digits / Segmente.....	Lower Row
Page 7 / Seite 7.....	Digits / Segmente.....	Lower Row
Page 8 / Seite 8.....	Board / Platine.....	

!!!!!!! CAUTION / VORSICHT !!!!!!!!

**Ensure that the HIGH VOLTAGE FUSES are removed
from the Power Supply Board !**

**Stellen Sie sicher, dass die HOCHSPANNUNGSSICHERUNGEN
von der Spannungsversorgungsplatine entfernt sind !**

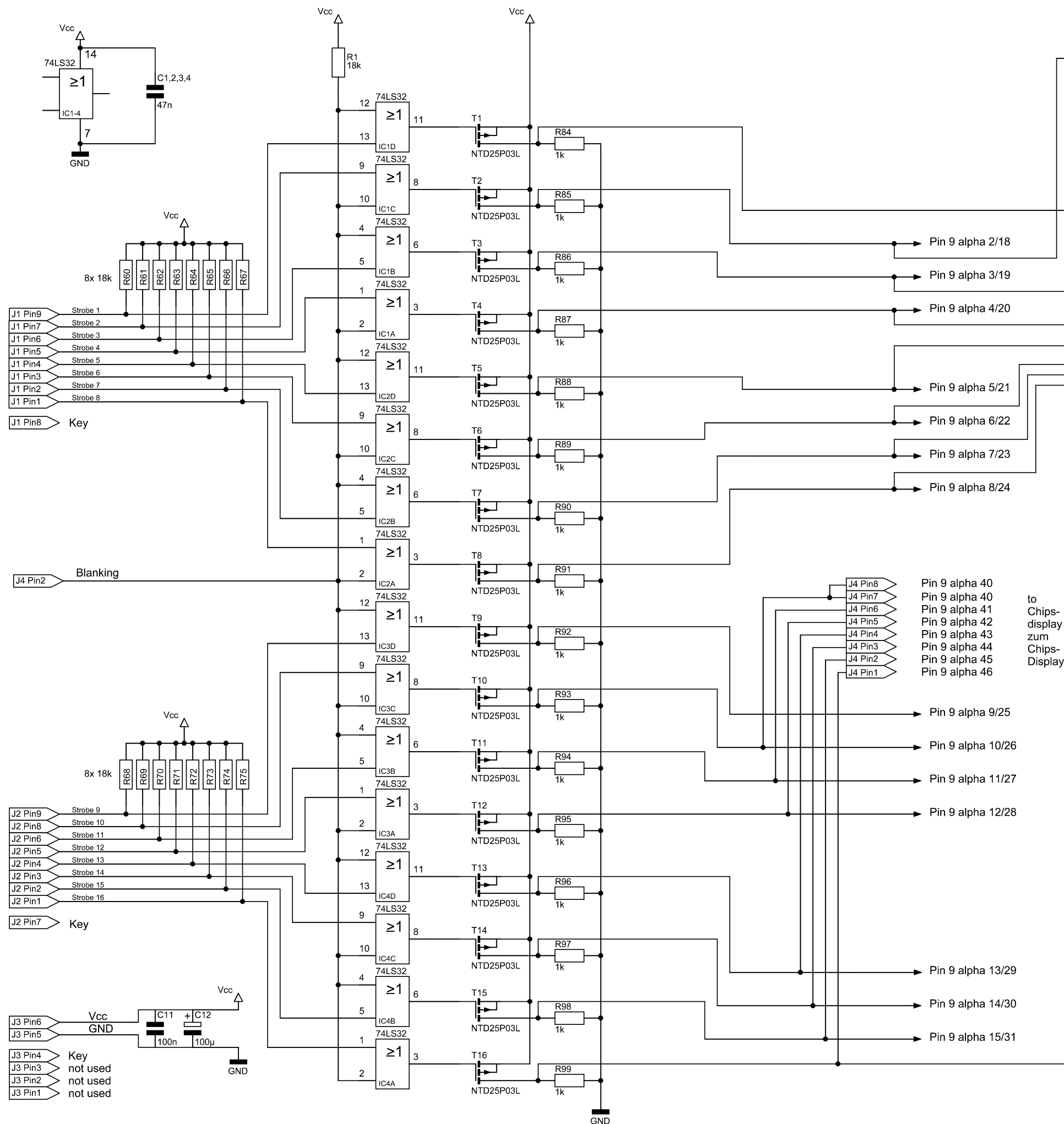

J6 Pin8 → Pin 9 alpha 33
 J6 Pin7 → Pin 9 alpha 33
 J6 Pin6 → Pin 9 alpha 34
 J6 Pin5 → Pin 9 alpha 35
 J6 Pin4 → Pin 9 alpha 36
 J6 Pin3 → Pin 9 alpha 37
 J6 Pin2 → Pin 9 alpha 38
 J6 Pin1 → Pin 9 alpha 39

to Jackpot-display zum Jackpot-Display

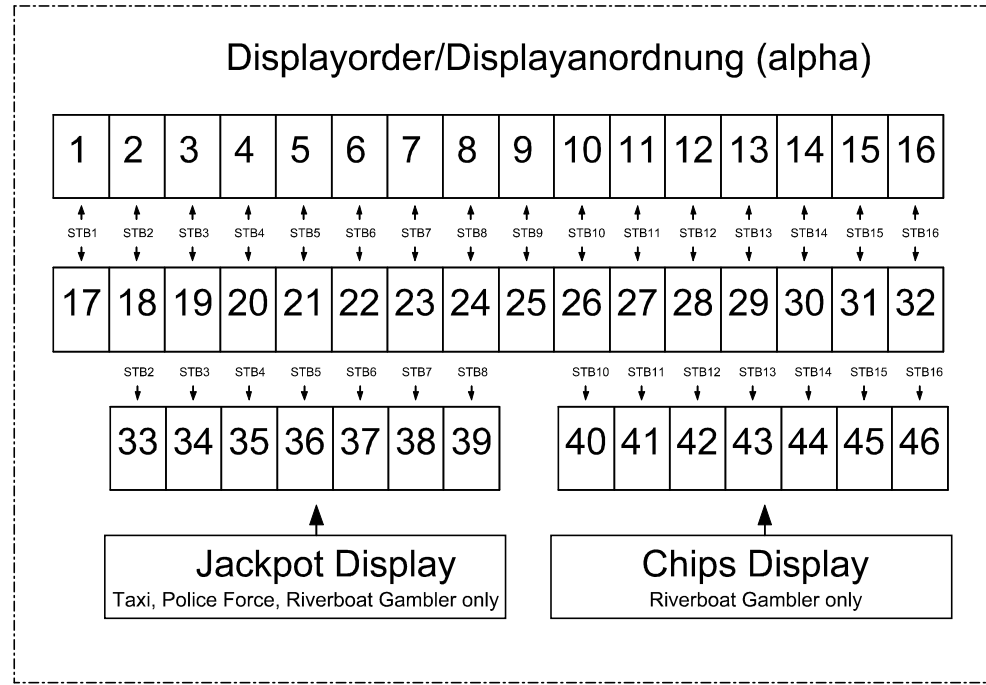
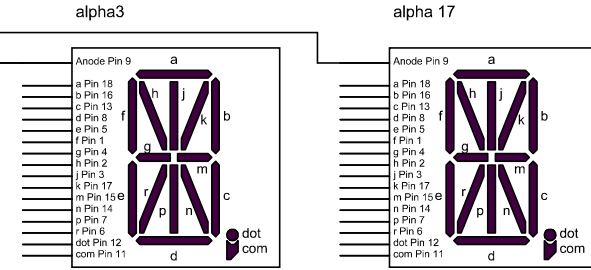

to Chips-display zum Chips-Display

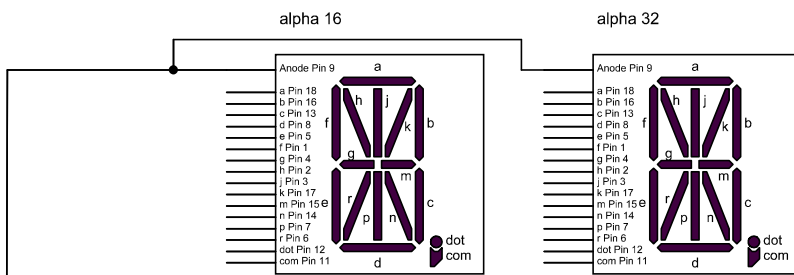

Notes:

Date: 02/03/07
 Name: A.Förster
 Copyright 2007 by A.Förster

Strobes

PinLED

PN: 2003001
 Rev: 05
 Boardname: 10101

SWITCH SETTINGS:
 S1,S2,S3,S4 to OFF => Data East
 S1 to ON, S2,S3,S4 to OFF => Williams
 S1,S2,S3,S4 to ON => Williams (only TAXI, POLICE FORCE
 and RIVERBOAT GAMBLER)

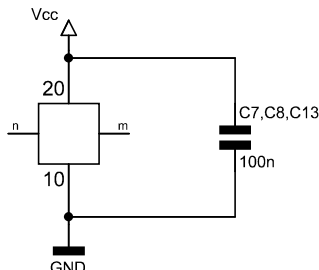
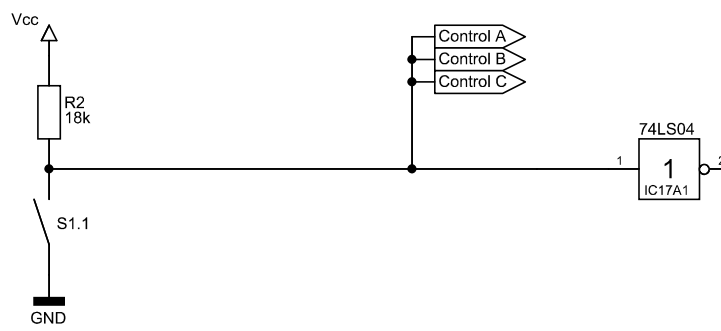
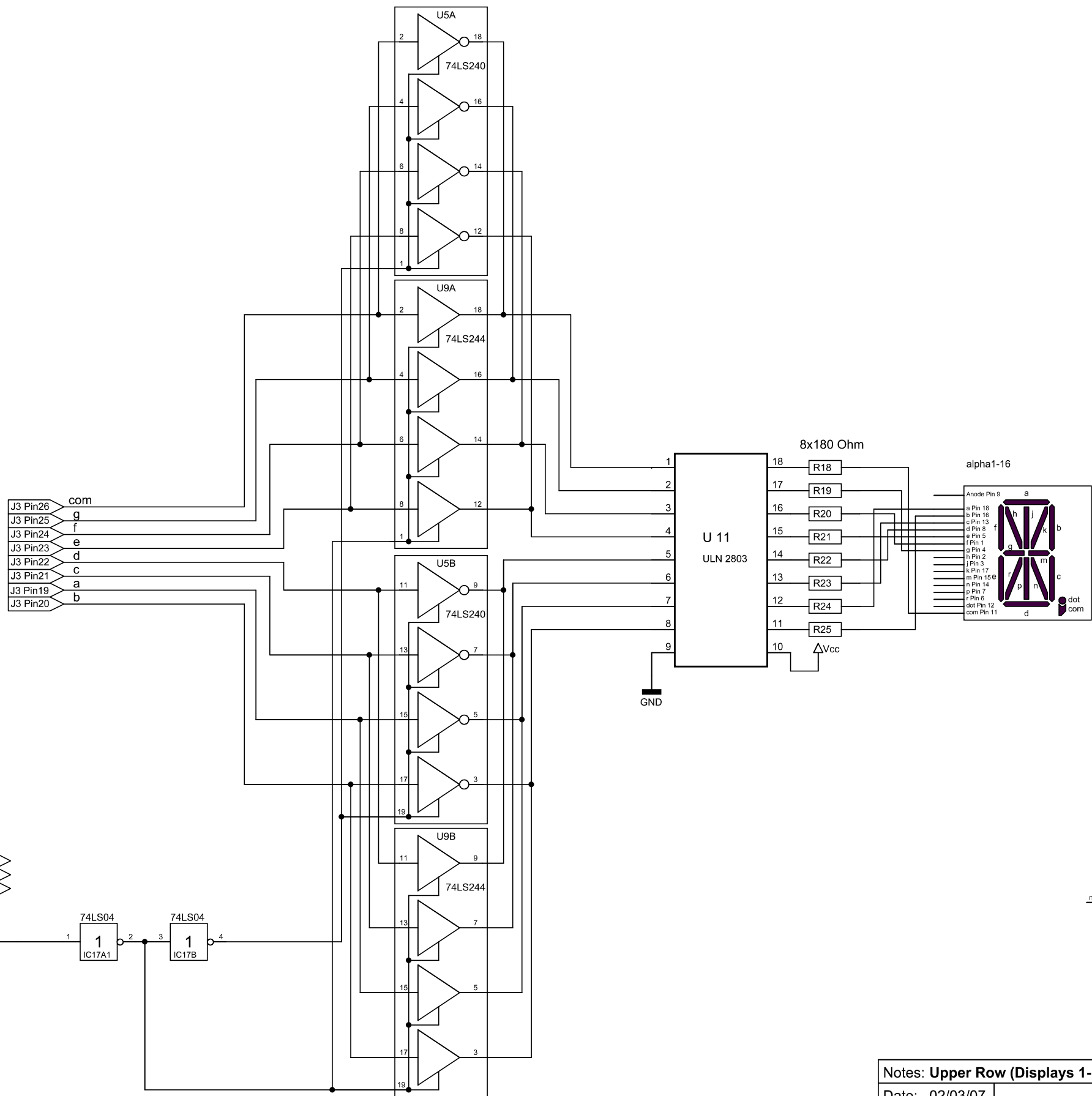

Notes: Upper Row (Displays 1-16)		
Date: 02/03/07	Digits PinLED	PN: 2003001
Name: A.Förster		Rev: 05
Copyright 2007 by A.Förster		Boardname: 10101

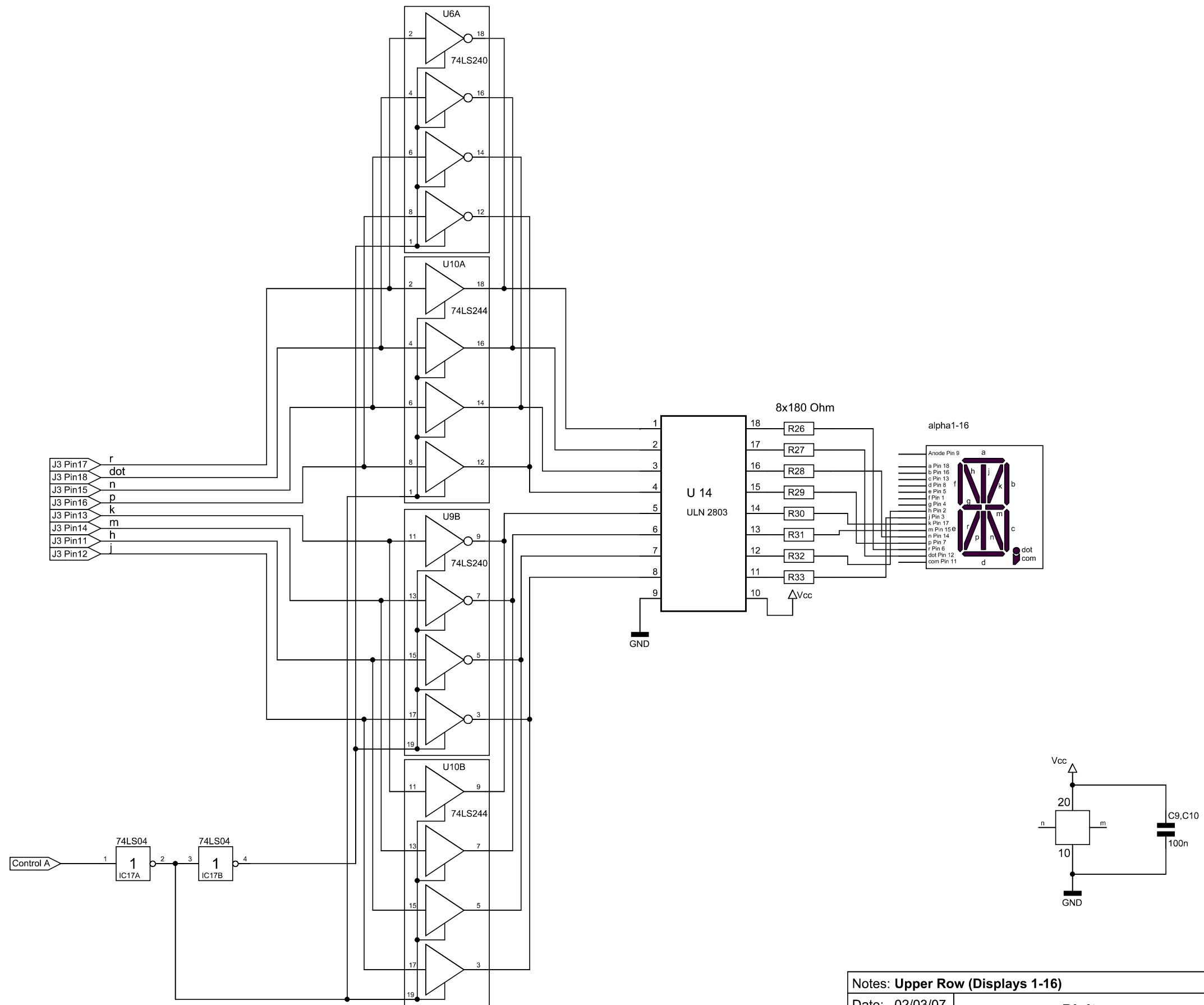

Notes: Upper Row (Displays 1-16)		
Date: 02/03/07	Digits	PN: 2003001
Name: A.Förster		Rev: 05
Copyright 2007 by A.Förster	PinLED	Boardname: 10101

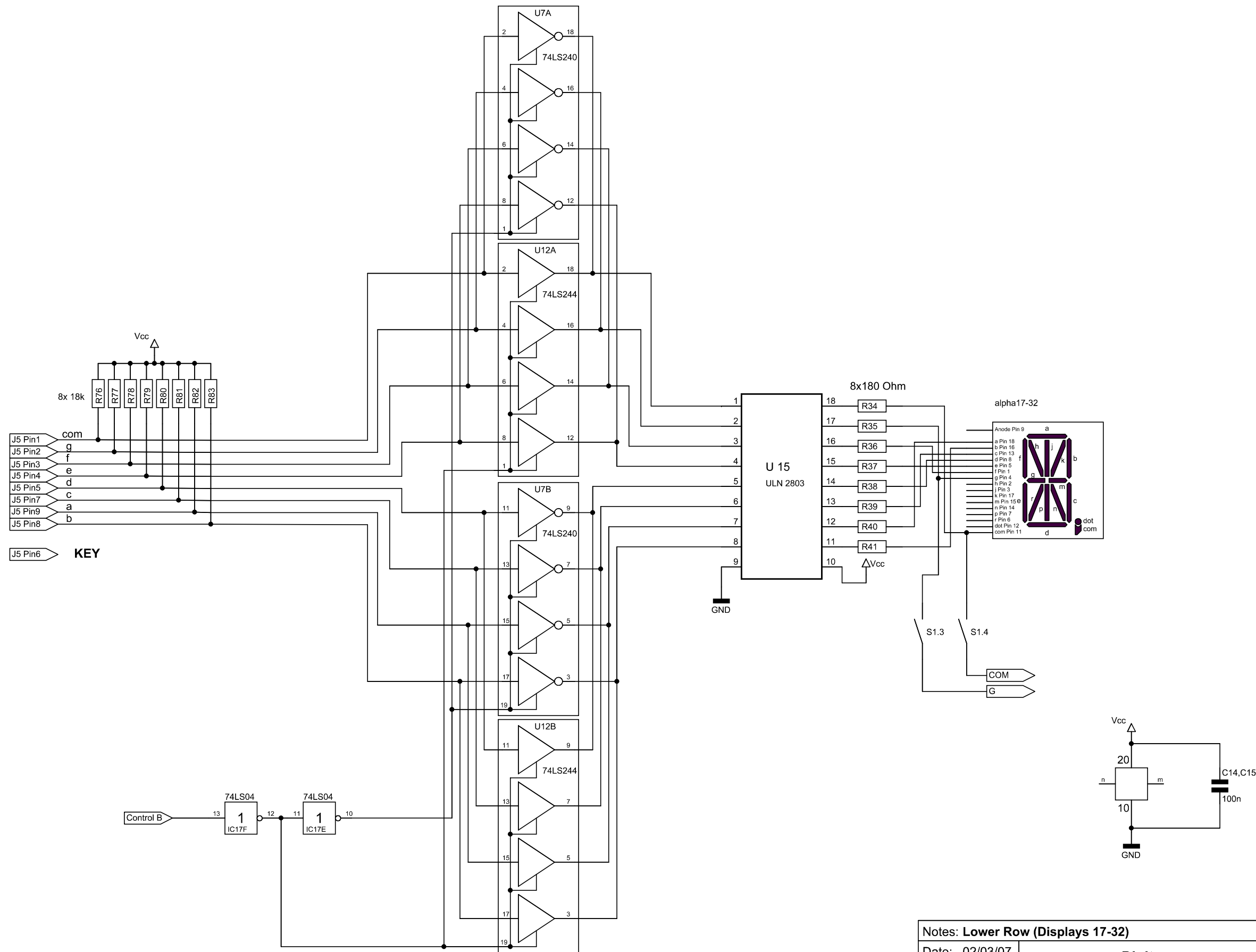

Notes: Lower Row (Displays 17-32)		
Date: 02/03/07	Digits	PN: 2003001
Name: A.Förster		Rev: 05
Copyright 2007 by A.Förster	PinLED	Boardname: 10101

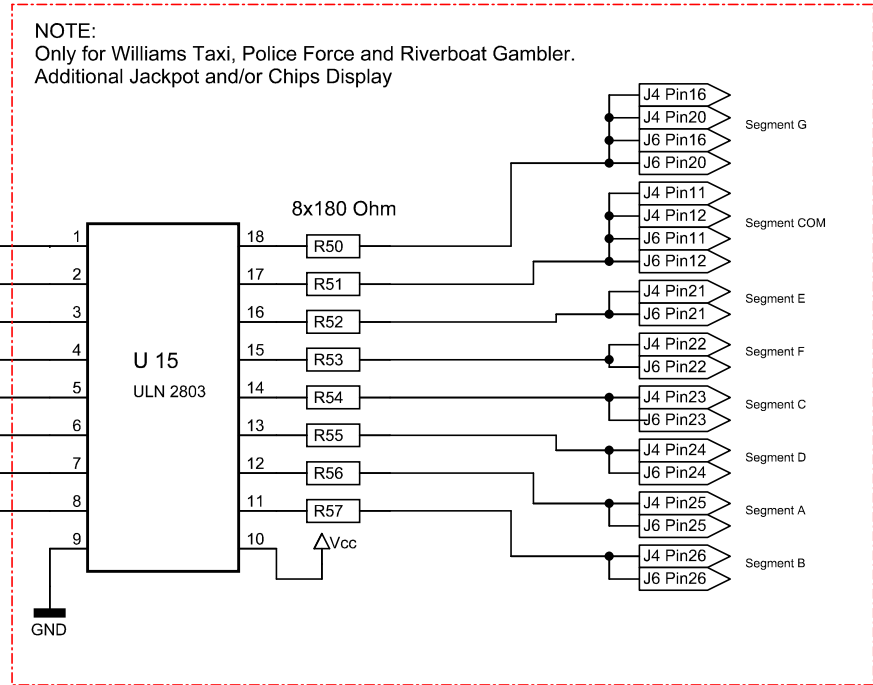
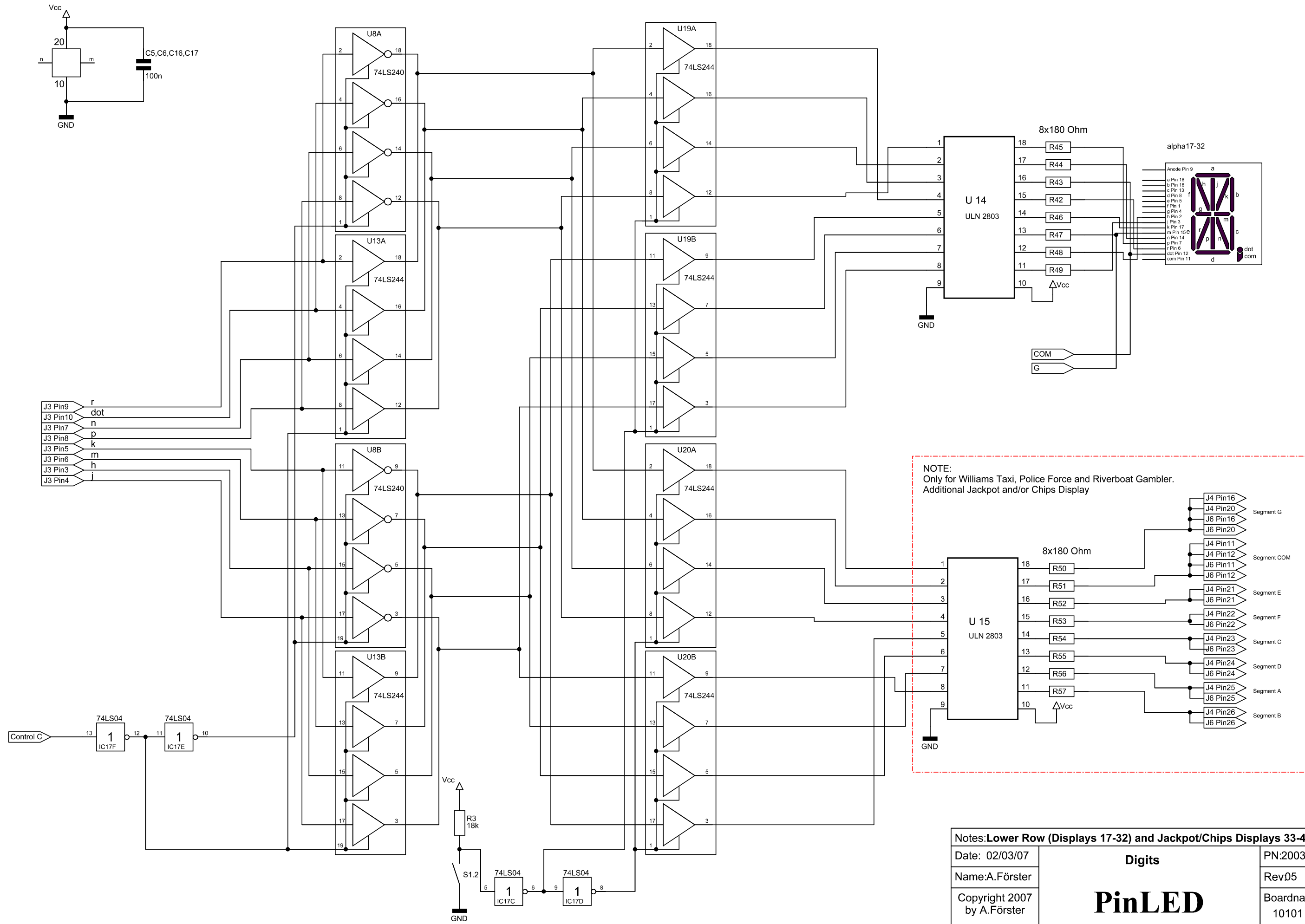

Notes: Lower Row (Displays 17-32) and Jackpot/Chips Displays 33-42		
Date: 02/03/07	Digits	PN:2003001
Name: A.Förster		Rev:05
Copyright 2007 by A.Förster	PinLED	Boardname: 10101

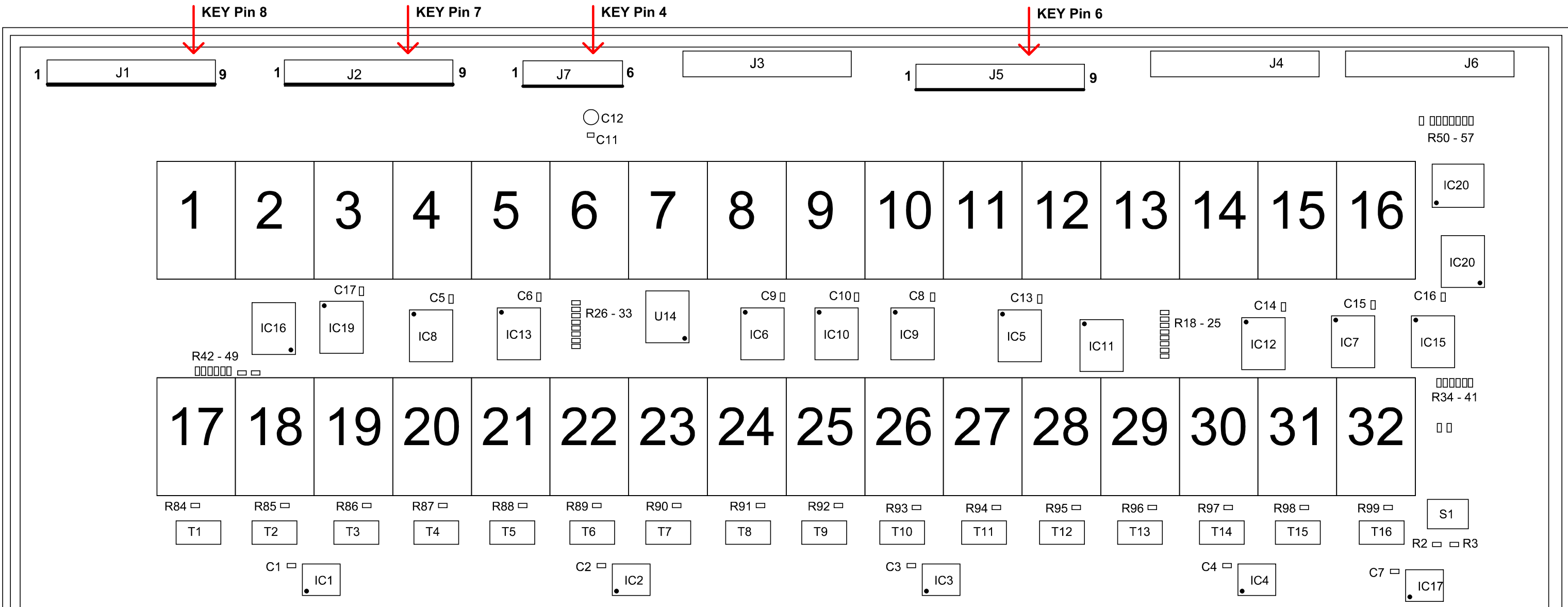

LED-Display Board PN: 2003001 Rev D 10101

- IC1, IC2, IC3, IC4.....74LS32
- IC11, IC14, IC15, IC16, IC18.....UDN 2803
- IC17.....74LS04
- IC5, IC6, IC7, IC8.....74LS240
- IC9, IC10, IC12, IC13, IC19, IC20.....74LS244
- T1 - T16.....NTD25P03L
- C1 - C11, C13 - C17.....100nF.....0805
- C12.....100µF/16Volt
- R1 - R3, R60 - R83.....18k Ohm.....1206
- R18 - R 57.....180 Ohm.....1206
- R84 - R99.....1k Ohm.....1206
- S1.....4x DIP SW

All Resistors are 1/4 W.....Alle Widerstände 1/4 W

Notes:	10101	
Date: 02/04/07	PinLED	PN: 2003001
Name: A.Förster		Rev: 05
Copyright 2007 by A.Förster		Boardname: 10101