

1990 Janice Avenue
Melrose Park, IL 60160
708-345-7700
FAX 708-345-7718
1-800-KICKERS

DATA EAST PINBALL, INC. ®

Joe Blackwell
Technical Support Manager

Eric Winston
Technical Support

Jay Alfer
Technical Documentation Administrator

CPU JUMPER TABLE

Game	CPU* ROM		JUMPERS	
	Version	Position	INSTALLED	REMOVED
Laser Wars	Ver 1	5C	J1b, J3, J4, J6a, J7a, & J8	J1a, J2, J5, J6, J7b
	Ver 2	5B, 5C	J1b, J3, J4, J5a, J6a, J7b & J8	J1a, J2, J5, J5b, J6b & J7b
Secret Service	Ver 2	5B, 5C	J1b, J3, J4, J5b, J6b, J7b & J8	J1a, J2, J5, J5a, J6a & J7a
Torpedo Alley	Ver 2	5B, 5C	J1b, J3, J4, J5b, J6b, J7b & J8	J1a, J2, J5, J5a, J6a & J7a
Time Machine	Ver 2	5B, 5C	J1b, J3, J4, J5b, J6b, J7b & J8	J1a, J2, J5, J5a, J6a & J7a
Playboy	Ver 2	5B, 5C	J1b, J3, J4, J5b, J6b, J7b & J8	J1a, J2, J5, J5a, J6a & J7a
ABC M.N. Football	Ver 2	5B, 5C	J1b, J3, J4, J5b, J6b, J7b & J8	J1a, J2, J5, J5a, J6a & J7a
Robocop	Ver 2	5B, 5C	J1b, J3, J4, J5b, J6b, J7b & J8	J1a, J2, J5, J5a, J6a & J7a
Phantom of the Opera	Ver 2	5B, 5C	J1b, J3, J4, J5b, J6b, J7b & J8	J1a, J2, J5, J5a, J6a & J7a
Back to the Future	Ver 3	5B, 5C	J1b, J3, J4, J5b, J6b, J7b & J8	J1a, J2, J5, J5a, J6a & J7a
The Simpsons	Ver 3	5B, 5C	J1b, J3, J4, J5b, J6b, J7b & J8	J1a, J2, J5, J5a, J6a & J7a
Checkpoint	Ver 3	5B, 5C	J1b, J3, J4, J5b, J6b, J7b & J8	J1a, J2, J5, J5a, J6a & J7a
Teen. Mut. Ninja Turtles	Ver 3	5B, 5C	J1b, J3, J4, J5b, J6b, J7b & J8	J1a, J2, J5, J5a, J6a & J7a
Batman	Ver 3	5B, 5C	J1b, J3, J4, J5b, J6b, J7b & J8	J1a, J2, J5, J5a, J6a & J7a
Star Trek	Ver 3	5C	J1b, J3, J5, J5b, J6b, J7b & J8	J1a, J2, J4, J5a, J6a & J7a
Hook	Ver 3	5C	J1b, J3, J5, J5b, J6b, J7b & J8	J1a, J2, J4, J5a, J6a & J7a
Lethal Weapon 3	Ver 3	5C	J1b, J3, J5, J5b, J6b, J7b & J8	J1a, J2, J4, J5a, J6a & J7a
Star Wars	Ver 3	5C	J1b, J3, J5, J5b, J6b, J7b & J8	J1a, J2, J4, J5a, J6a & J7a
Rocky & Bullwinkle	Ver 3	5C	J1b, J3, J5, J5b, J6b, J7b & J8	J1a, J2, J4, J5a, J6a & J7a
Jurassic Park	Ver 3	5C	J1b, J3, J5, J5b, J6b, J7b & J8	J1a, J2, J4, J5a, J6a & J7a
Last Action Hero	Ver 3	5C	J1b, J3, J5, J5b, J6b, J7b & J8	J1a, J2, J4, J5a, J6a & J7a
Tales from the Crypt	Ver 3	5C	J1b, J3, J5, J5b, J6b, J7b & J8	J1a, J2, J4, J5a, J6a & J7a
The Who's Tommy	Ver 3	5C	J1b, J3, J5, J5b, J6b, J7b & J8	J1a, J2, J4, J5a, J6a & J7a
* Version 1 hat ein 2K RAM und ist einem 24-poligen IC in Position 5D.			* Version 2 & 3 hat ein 8K RAM und ist einem 28-poligen IC in Position 5D.	

Power-Up CPU Self Tests

Upon power-up, the CPU Board performs a series of self tests of major components. Turn the game on while observing the LEDs on the CPU Board. Tests of the PIAs, RAM, and EPROMs are performed automatically and results of the tests are indicated by the PIA LED.

With all tests passed, the LEDs illuminate in the following sequence at power turn-on. The PIA and +5v LED illuminate immediately. Approximately 1/2-second later, the PIA LED goes out and the Blanking LED illuminates. The +5v and Blanking LEDs remain illuminated until the game is turned off. Test failures are indicated with the PIA LED:

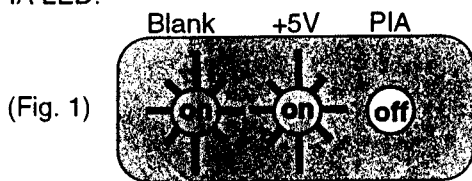

PIA LED	SUSPECT COMPONENT
Stays On	One of the 6821 PIAs
Flashes 1 Time	6264 RAM at location D5
Flashes 2 Times	EPROM at location C5

DISPLAY READS "OPEN THE DOOR" -- This indicates a faulty memory condition in RAM. Opening the Coin Door will initiate a Factory Restore, by opening the Memory Protect Switch. Check battery voltage at CMOS RAM with power off.

QUICK REFERENCE FUSE CHART

PPB BOARD	POWER SUPPLY BOARD
F1 5A Slo-Blo G.I. 6.3VAC	F1 7A Slo-Blo +5VDC Regulator Input (9VAC)
F2 5A Slo-Blo G.I. 6.3VAC	F2 7A Slo-Blo +5VDC Regulator Input (9VAC)
F3 5A Slo-Blo G.I. 6.3VAC	F3 Not Used
F4 5A Slo-Blo G.I. 6.3VAC	F4 8A Slo-Blo Switched Illumination Buss (18VDC)
F5 5A Slo-Blo Flipper Power & 50VOLT coils	F5 5A Slo-Blo Solenoid (34VDC) Bumpers Slingshots e
F6 5A Slo-Blo Flash Lamps (34VDC)	F6 5A Slo-Blo Solenoid Buss (34VDC)
F7 3A Slo-Blo Flipper Power & 32VOLT coils	F7 0.5A Slo-Blo Display Reg. Input (90VAC)
F8 4A Slo-Blo 50VOLT coils	
F9 5A Slo-Blo 50VOLT coils	

The Who's Tommy TABLE OF CONTENTS

GAME SPECIFICATIONS	1
Power Requirements	1
PROM Summary	1
Transportation	1
Overall Dimensions	1
Game Assembly Procedures.....	2
Easy Access Service System.....	3
Backbox Layout, Fuse & Relay Locations.....	4
GAME OPERATION & FEATURES	5
Standard Features.....	5
Extra Ball (EB) Buyin Feature	5
Manual Percentaging	5
Instruction Card & Game Rules.....	5
AUDIT FUNCTIONS	13
General	13
Audits - 'Quick Look' Functions (1- 12)	13
Audit Table	14
Audits - Expanded Generic Functions (13 - 45)	15
Audits - Game Specific Functions (46 - 64)	16
GAME ADJUSTMENTS.....	19
General	19
Replay and Generic Features, Replays (Adj. 1-6).....	19
Game Adjustment Table.....	20
Single-Function Difficulty Adjustments (Adj. 7)	21
Novelty/5-Ball/Add-A-Ball Settings	21
Game Price (Adj. 8)	22
Custom Pricing Table	22
Standard Pricing Table.....	23
Additional Generic Features (Adj. 9 - 39).....	24
Game Specific Features (Adj. 40 - 58, & 99).....	26
GAME DIAGNOSTICS	29
Entering Diagnostics	29
Service Credits.....	29
Tech Alert.....	29
Easy Trough Clear	30
Burn In Minutes	30
Sound Tests & Chart	30
Speaker Phase Testing	30
Digital Display Test.....	31
Dot Matrix Display Test	31
Mirror Up & Down Test.....	31
Arch Motor Test.....	31
Switch Tests & Switch Matrix Chart	32
Switch Matrix Locations, Descriptions & Switch Part Numbers	33
Lamp Tests & Lamp Matrix Chart.....	34
Lamp Matrix Locations & Descriptions	35
Flash Lamp/Coil Tests.....	36
Switch, CPU Controlled Auxillary & Constant Power Chart	37
Coil Chart	38
PARTS IDENTIFICATION	39
Cabinet Parts Illustration	39
Playfield - Major Assemblies	40
Playfield - Major Ramp Assemblies & Related Parts	41

Continued on the next page.

Parts Identification Cont.	
Playfield - Backbox Parts	42
Playfield - Rubber Parts	42
Playfield Top Parts	43
Socket Part Numbers & Illustrations	44
Lamp Board Layouts & Lamp Bulb Part Numbers.....	45
UNIQUE PARTS (BLUE SECTION)	47
6-Ball Switch Assembly (500-5683-01)	47
Lock Ball Assembly (500-5684-01).....	47
Deflector (535-6606-01).....	47
Flipper Assembly Lower (500-5693-01 Right; -02 Left)	48
Flipper Assembly Upper (500-5756-02, Left).....	49
Slingshot Assembly (500-5226-00)	50
Turbo Bumper (500-5227-00)	51
Knocker Assembly (500-5081-00)	51
Shooter/Kicker (Auto Ball Launch) Assembly (500-5797-00)	52a
Shooter Assembly Long Shaft (500-5744-00-04)	52a
Shooter/Kicker (Auto Ball Launch) Assembly (500-5769-00* used in early production games).....	52b
Super VUK Assembly (500-5116-06)	53
Super VUK/Scoop Assembly (500-5716-00)	54
Ball Deflector (500-5788-00).....	55
Motor, Cam & Switch Assembly (500-5742-01)	56
Target Back Plate Guide Assembly (515-5905-XX)	57
Blinder Assembly (Top & Side View) (500-5775-00)	58
Airplane (Bomber) Assembly (515-5949-00)	59
SCHEMATICS/TROUBLESHOOTING (YELLOW SECTION)	61
Power Wiring Diagram.....	61
Cabinet Wiring Diagram	62
Backbox Wiring Diagram	63
Playfield Coil/Flashlamp Wiring Diagram	64
Playfield Special Coil Diagram	65
Playfield Switch Wiring Diagram	66
Playfield Lamp Wiring Diagram	67
CPU Board Assembly Diagram	68
CPU Board Logic Diagram (Sheets 1-4)	69-72
Power Supply Board Schematic	73
Sound Board (520-5077-00) Schematic	74
Combined Display Connections	75
Display Controller Board Component Layout	76
Display Controller Board Schematic.....	77
Display Driver, Drawing 1 (CHERRY)	78
Display Driver, Drawing 2 (BABCOCK)	79
Display Driver, Drawing 3 (DALE)	80
NEW Solid State Flipper Coils & Wiring Diagram	81
NEW Solid State Flipper Board Schematic	82
NEW Solid State Flipper Switch Wiring Diagram & Theory of Operation	83
NEW Solid State Flipper Circuit Troubleshooting Flowchart	84
Pinball Servo Controller Board Theory of Operation & Schematic	85
Pinball Servo Controller Adjustment Procedure for Blinders	86-87

GAME SPECIFICATIONS

POWER REQUIREMENTS

This game is provided with a 3-prong plug and **must be connected to a properly grounded outlet to reduce shock hazard** and insure proper game operation. Refer to AC Power Wiring Diagram for transformer connections required for normal, high, and low line conditions.

Normal Line: 109 to 129 -Volts AC (211 to 225 -Volts AC)
High Line: (226 to 235 -Volts AC)-- European, International
Low Line: 95 to 108 -Volts AC (200 to 210 -Volts AC)

PROM SUMMARY

CPU Board: Location C5
Sound Board: Locations U17 (Voice ROM 1), U21 (Voice ROM 2), U36 (Voice ROM 3), U37 (Voice ROM 4) and U7 (Sound ROM)
Display Controller Board: Location U12, ROM 0

TRANSPORTATION

To reduce the possibility of damage, observe the following precautions whenever transporting the game. Lower the backbox and secure it to the cabinet. Remove the legs and secure the game within the transporting vehicle.

OVERALL DIMENSIONS

Please Note
 An addition of a Marquee to the top of the backbox will increase the overall height of the back dimensions.

Shipping Crate Dimensions	
Height	55-1/2"
Width	30-1/2"
Length	31"
Approx. Wt.	250lbs.

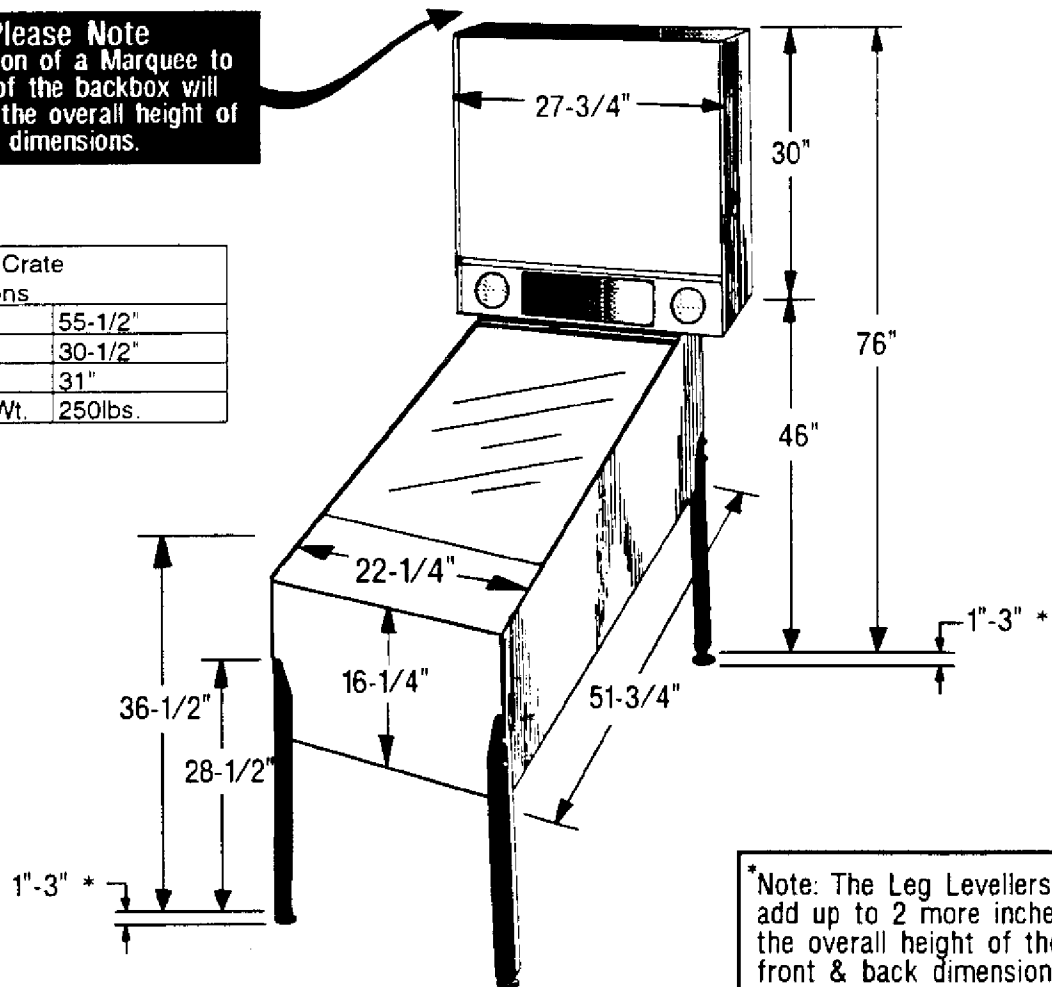

GAME ASSEMBLY PROCEDURES

(Refer to the Illustrations on pages 3 & 4)

1. Open the top of the carton and lay it on its side with the bottom of the cabinet down. Using the plastic banding strip as a handle, slide the game out of the carton.
 2. Remove all packing material. Cabinet legs are located on top of the front moulding above the coin door and the assembly parts package is in the cashbox. There should be four leg levelers, eight leg bolts, six pinballs and a large Allen Wrench, used for securing the backbox, is inserted & taped to the rear of cabinet.
 3. Attach leg leveler from the parts package to each leg, make sure that each leveler is threaded through a hex nut before threading it into the leg.
 4. Support rear of cabinet and attach rear legs using two leg bolts for each leg.
 5. Support front of cabinet and attach front legs using two leg bolts for each leg.
 6. While assuring that no cables are being pinched, carefully raise the backbox and secure it in its upright position with the Allen Wrench in the hole in the back of the cabinet and rotating the wrench 270 degrees(3/4 turn).
 7. Remove the backbox keys from the playfield glass, unlock and carefully remove the backglass. Set the backglass aside.
 8. Check all connectors in the backbox for loose wire terminations. Reseat any loose wire by pushing in on the terminal. Push on all connectors plugged into the CPU board, Sound Board, Power Supply Boards, and (on insert board) Display board to check that they are properly seated.
 9. Check that the fuses on the Power Supply board, PPB board and fuse panel are seated properly.
 10. Carefully remove the playfield glass and set it aside.
 11. Raise the playfield and support it, by lifting the Stay Arm on the Right Side of the Cabinet and locking it into the slotted bracket on the playfield. (Use the instruction sheet provided in the game to see alternative methods of accessing the playfield bottom.)
 12. Check all cabinet cable and playfield lamp board connector terminations.
 13. Remove all shipping tie downs.
 14. Remove the Plumb Bob tilt from the parts package and install on the pendulum wire on the inside left of the cabinet. (See Cabinet Parts Illustration.)
 15. Lower the playfield and level the playfield side-to-side by adjusting leg levelers.
 16. Using a level or slope indicator, adjust the pitch of the playfield to approximately 6.5 degrees.
- THE PLAYFIELD INCLINE AFFECTS DIFFICULTY OF PLAY. USE THE RECOMMENDED INCLINE; GAME DIFFICULTY IS BEST VARIED USING GAME ADJUSTMENTS.**
17. Check the plumb tilt and adjust as required.
 18. If desired, perform any self tests at this time. With the insert door closed, carefully reinstall and lock the backglass.
 19. Place the six pinballs on the playfield near the outhole and carefully reinstall the playfield glass.
 20. If desired, make game pricing and Add-A-Ball, Novelty, or 5-Ball Play adjustments at this time.

EASY ACCESS SERVICE SYSTEM

PREVENTIVE MAINTENANCE

Lubricate slide rails with light oil periodically to assure smooth operation.

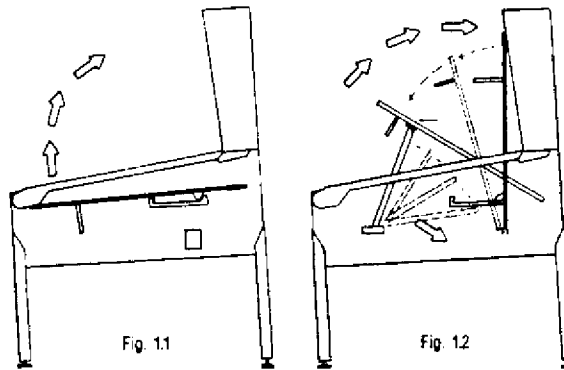

This position is useful to service:

Transformer, Cabinet Bottom Components, Playfield Bottom Components, etc.

SERVICE POSTION 1

Lift the playfield **using the left and right ball guides** upward and toward the backbox (Fig. 1.1) until the playfield can be supported with one hand. With your free hand, lift up support bar, while simultaneously lowering the playfield until the playfield and the support bar meet. Position it into the slotted bracket under the playfield. (Fig. 1.2) This bar will secure the playfield for servicing in an upward position. (Fig. 1.2). **Reverse procedure when service is complete.**

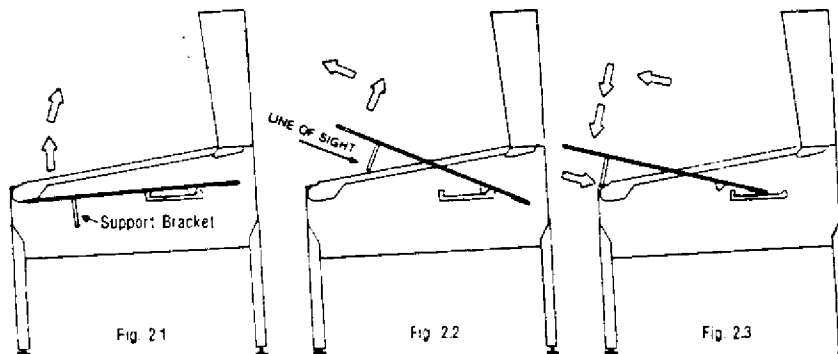

This position is useful to service:

Trough Switches, Connectors at back of cabinet, Cleaning the Playfield, etc.

SERVICE POSTION 2

Lift the playfield **using the left and right ball guides** upward (Fig. 2.1) until the playfield support brackets can be seen to clear cabinet front (Fig. 2.2). At this time, pull playfield toward the front of the cabinet, checking that the mechanical components clears the cabinet front (Fig. 2.3). Then rest the playfield on the support brackets at the front channel of cabinet. **Reverse procedure when service is complete.**

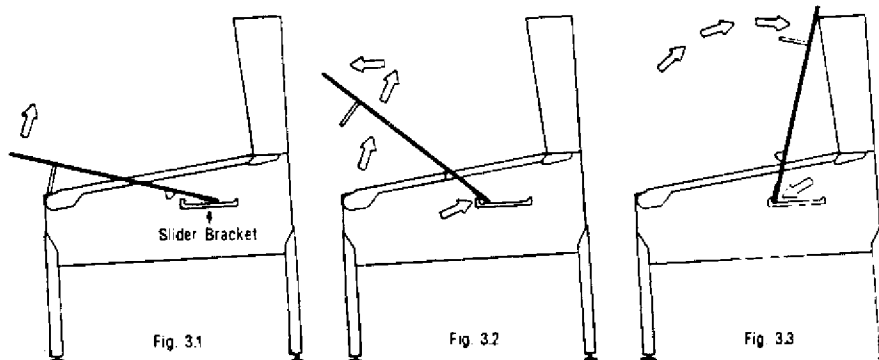

This position is useful to service:

All Playfield Bottom Components, Cabinet Components, etc.

SERVICE POSTION 3

With the playfield at rest (Fig. 3.1), hold sides of playfield and pull toward the front of the cabinet (approximately 6-8"), until resistance is felt from the slider brackets located on either side of the cabinet (Fig. 3.2). At this time, swivel playfield toward the backbox, then rest on top edge of the backbox. **Reverse procedure when service is complete.**

BACKBOX LAYOUT, FUSE & RELAY LOCATIONS

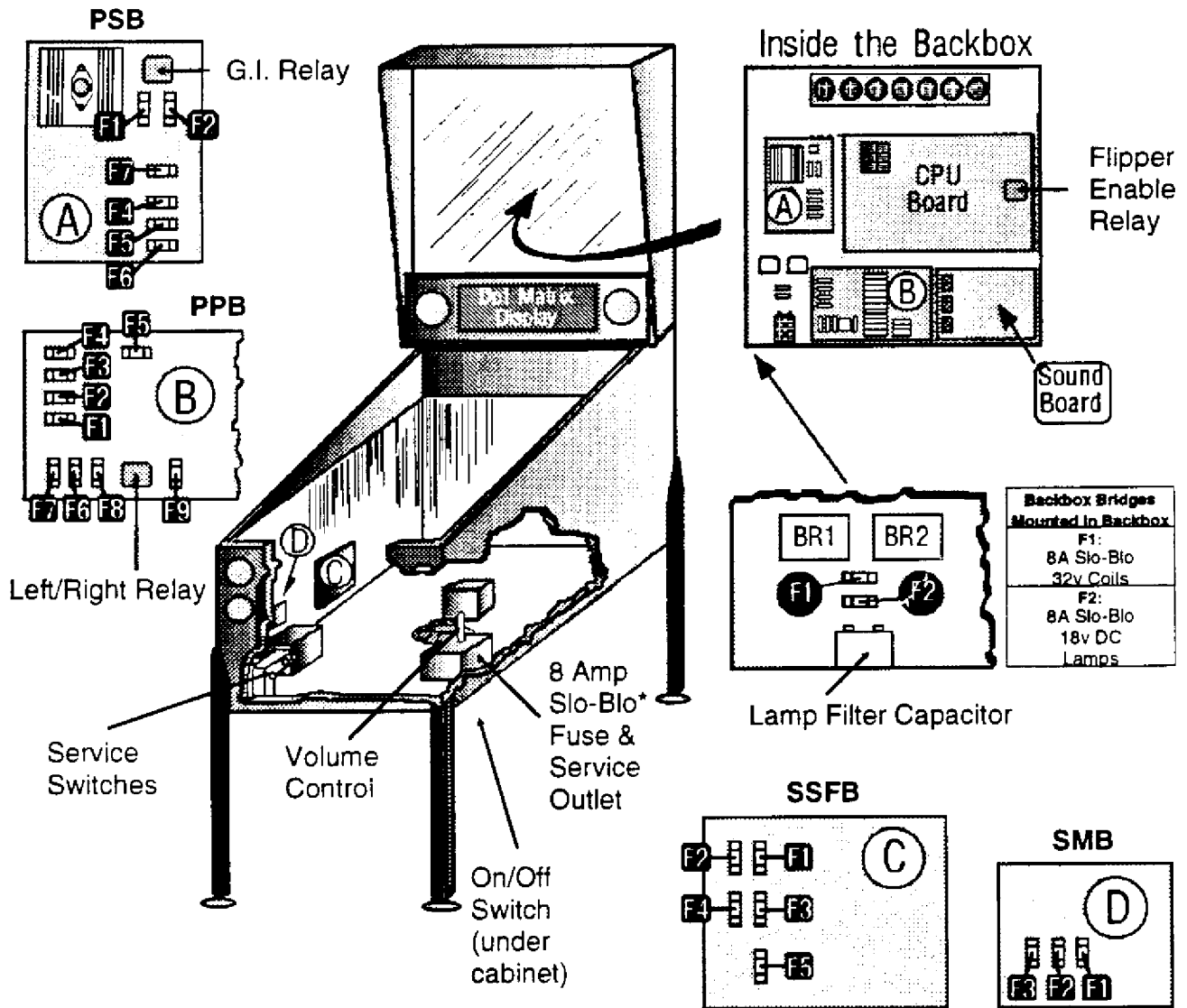

A: In the Backbox	
Power Supply Board PSB	
F1	7A Slo-Blo +5vDC Regulator Input (9vAC)
F2	7A Slo-Blo +5vDC Regulator Input (9vAC)
F3	Not Used
F4	8A Slo-Blo Switched Illumination Buss (18vDC)
F5	5A Slo-Blo Solenoid (34vDC) Bumpers, Slingshots, etc.
F6	5A Slo-Blo Solenoid Buss (34vDC) L/R Relay Coils/Flash
F7	0.5A 250v Slo-Blo Display Reg. Input (90vAC)

B: In the Backbox	
Playfield Power Board PPB	
F1	G.I. 5A Slo-Blo Playfield
F2	G.I. 5A Slo-Blo Backbox Dr./Spkr. Panel
F3	G.I. 5A Slo-Blo Playfield & Coin Door
F4	G.I. 5A Slo-Blo Backbox Door
F5	50v 5A Flippers /All 50v Coils
F6	32v Flash Lamps /Right
F7	32v 3A Coils /Left
F8	50v 4A / 50v Coils
F9	50v 5A Laser Kick

C: In the Cabinet	
Solid State Flipper Bd. SSFB	
F1	3A 250v Slo-Blo 50v DC Output (All Fuses) Lower RT Flipper
F2	3A 250v Slo-Blo 9v AC Holding
F3	3A 250v Slo-Blo 50v DC Output LT Flipper
F4	3A 250v Slo-Blo 9v AC Holding
F5	3A 250v Slo-Blo 50v DC Output Upper Flipper

D: In the Cabinet	
Shaker Motor Board SMB	
F1	2.5Amp Slo-Blo Airplane Motor
F2	Not Used
F3	Not Used
* Cabinet Fuses	
Main Fuse Line:	
8Amp 250v Slo-Blo	
International:	
4Amp 250v Slo-Blo	

GAME OPERATION & FEATURES

STANDARD FEATURES

Insert coin(s), the game makes a sound for the first credit and generates sounds for each subsequent coin and the display indicates the number of credit(s) posted. Depress the credit button and a start-up sound is produced, the posted credit(s) are reduced by one. The display now indicated the player or # of players selected from the total depressions of the credit button. The display indicates the ball in play, and a ball is served to the shooter lane. Additional players may be added by depressing the Credit button before the end of ball 1. At game start, an introduction is shown followed by Skill Shot Graphics.

The second closure (adjustable) or prolonged closure of the plumb bob tilt switch tilts the ball in play. Closure of the slam tilt switch in the coin door ends the current game(s).

At the end of each ball, earned bonuses are collected. At the end of the last ball for the last player and after bonuses are collected. The EB Buyin Feature* countdowns awaiting for player to enable. If countdown reaches zero the system produces a random 2-digit number (a multiple of 10; 00 to 90) for a Match feature (adjustable). Matching the last two digits of a player score with this number awards a credit. Players exceeding high score levels receive free credits (adjustable) and are able to enter their initials with the new High Score achieved. To enter your initials, use the left & right flipper buttons to choose letter or character as seen on the Visual Display. Hitting the Start Button locks the letter or character in. Proceed with the 2nd & 3rd letter. The game then proceeds into the game-over mode and then to the attract mode. A custom message (adjustable) can be displayed during the attract mode.

*EXTRA BALL (EB) BUYIN FEATURE

An option to add an extra ball after game is finished, prior to completion of "countdown." For the same credit, player may choose to continue the game at the same score and features active by depressing the E-Ball Button. The number of extra balls which can be added to a game can be adjusted with Adj. 57.

MANUAL PERCENTAGING

This game is equipped with Manual Percentage Adjustment. As previously with our games, you can either set operator adjustments for a replay percent or you can set a fixed replay score.

If you set operator adjustments for a particular replay percent, the game will compute a recommended score to keep the game at that replay percentage. If a change is recommended and the game coin door is opened, the displays will indicate a recommended replay score to beat and make a sound to alert the operator. By pressing the start button, the score to beat will be changed to the recommended level. If you close the coin door or go into audit or adjustment mode, no score change will be made.

You may choose to ignore the recommended change; for example, you may not think last week's players were the usual crowd. Just close the door and the message will disappear without altering the existing level. Or you may choose to make a different score to beat adjustment; this is done by utilizing Adjustment 02.

<i>Holder of this ticket agrees to the following:</i>	
Skill Shot : Plunge the ball into the secret hole behind the parachute.	8:00PM FRIDAY FEBRUARY 4, 1994 No Refunds/Exchanges
Multiball : Spell T-O-M-M-Y by shooting the mirror, then enter the mirror for 4-Ball Play.	Data East Theatre 1990 Janice Ave.
Jackpot : Shoot ramps to collect Jackpots, then spell T-O-M-M-Y at Mirror to light Super Jackpots.	<i>Presenting</i> The Who's TOMMY PINBALL
Union Jack : Orbit shot lights "Union Jack Collect"; Shoot "Union Jack Collect" to start flashing Feature.	
Genius Hole: Shoot the "eject" to collect various Skill Level awards.	
Mystery: Shoot the right ramp to light Mystery award at "eject."	
Hint : You can become <i>Tommy</i> by holding in the Extra Ball Button when starting your game!	
Part No. 755-5048-00	
GENERAL ADMISSION Admit One Per Credit	ROW J SEAT 21

INSTRUCTION CARD & GAME RULES

*Card may be
photocopied as a
temporary
replacement.*

GAME RULES

UNION JACK FEATURES:

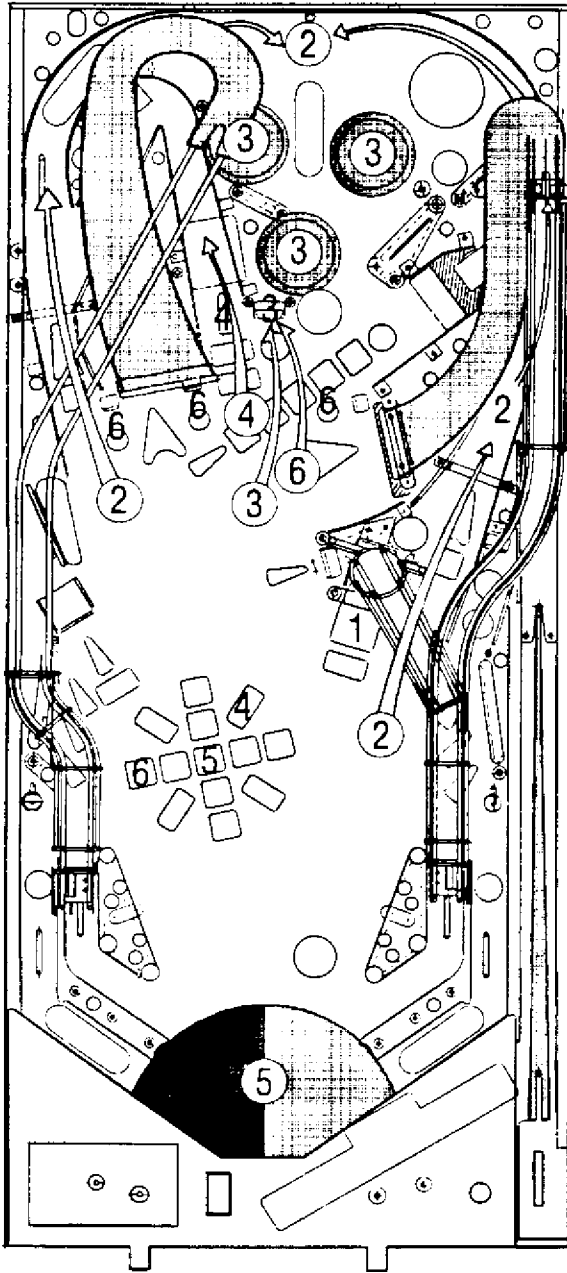

1

Collect Union Jack

Collect flashing Union Jack feature at VUK (Right Hole) when lit for "Collect Union Jack."

2

Light Union Jack

The left or right orbits relight "Collect Union Jack". The left or right return lanes may relight "Collect Union Jack" temporarily.

3

Change Union Jack

The switch closures on the Turbo Bumpers and Silver Ball Target change the lit Union Jack Feature.

GRID FEATURES:

4

Light Extra Ball

Extra Ball is collected at "Eject,"

5

Pinball Wizard

Blinder is extended out in this 6-Ball mode. Left ramp is worth 10M, right ramp is worth 20M, other switches are worth 1M. Pass switch closure checkpoints to spell WIZARD and earn WIZARD Letter Awards. Round ends when only 1-Ball remains in play.

6

Silver Ball Multi-Millions

20-second timed mode, more time available. Small targets lit for 5M each. Center target lit for 10M, increases by 5M each time hit and increases value at all small targets by 5M.

GAME RULES

Grid Features Continued:

7

Acid Queen

Untimed mode, more time not available. Countdown on eject, scoop, and VUK begins at 25M. If award is collected, 10M is added to countdown. Mode is over when countdown reaches 10M or all three shots are made.

8

Sally Simpson

20-second timed mode, more time available. Both left & right ramps initially score 5M and the left ramp scores double increments when shot (e.g. 5M, 7M, 9M, 11M, etc.) The right ramp awards ramp value and doubles awarded ramp value. (i.e. Example Shoot: Left Ramp --> 5M Awarded; Left Ramp --> 7M Awarded; Right Ramp --> 9M Awarded and both ramps now worth 18M.

9

Smash the Mirror

Untimed mode. 2-Ball multiball with balls recycled for 20-seconds. Mirror shots score 5M, 10M, 15M, 20M, and 25M. Mirror then lowers for a 50M shot. After this shot the cycle repeats. Mode ends when one ball remains in play.

10

Fiddle About

20-second timed mode, more time available. Shoot 3-Bank Targets. Value of bank 3-Bank Targets are 5M a piece (and increment by 1M per hit, to a maximum of 10M). Mode ends when timer expires.

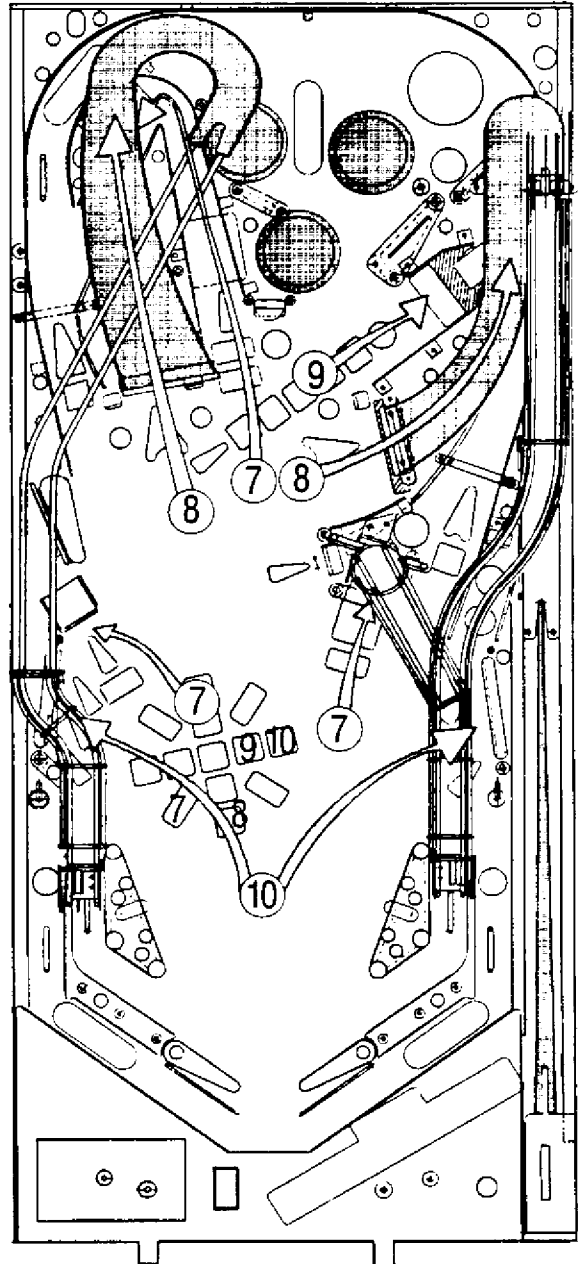

GAME RULES

Grid Features Continued:

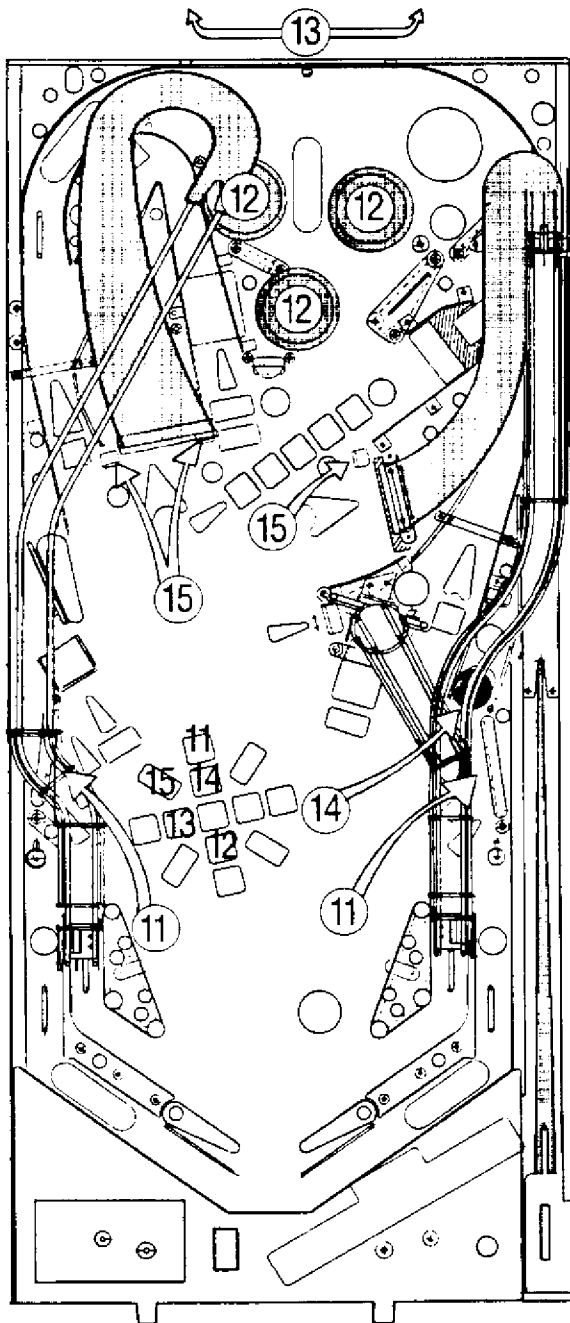

11

Christmas

20-second timed mode, more time available. Fast scoring, all switch closures initially 300K. 1 roving target on each 3-Bank adds 5M to fast scoring total. Any 3-Bank Target boosts increment by 100K. Mode ends when time expires.

12

There's A Doctor

25-second timed mode, more time available. 1M per Pop Bumper, 20 Pops total required for completion. 25M bonus for completion (20 hits), 5M Base, maximum total is 50M. Mode ends when timer expires or 20 pops made.

13

Captain Walker

Video Mode: Use flippers to drop bombs on the video targets below. Each target destroyed scores 1M.

14

Holiday Camp

Untimed mode, more time NOT available. Captive ball count up, 1M...20M, can collect multiple times. Mode ends when captive ball value reaches 20M.

15

Cousin Kevin

20-second timed mode, more time available. During the time period, ramp targets add-a-ball and score 5M X Balls-in-play. Each target may only add one ball. If all 3 targets are completed, then base value increases by 5M. If only 1 ball is in play when the timer expires, then the mode ends. If multiple balls are in play when the time is up, then the mode continues with ramp targets scoring Base value X Balls-in-play. Add-a-ball and increase in target value are no longer available once time is expired. In this case, the mode ends when only 1 ball is still in play.

GAME RULES

Grid Features Continued:

16

Tommy

Three ball fast scoring mode with arch active, more time NOT available. 3 Balls are fed into play with switch closures worth 500K. Round ends when only 1-Ball remains in play.

MULTIBALL RULES:

17

Collecting Multiball

Spell T-O-M-M-Y at the mirror to lower mirror and light 4-Ball Multiball. 3-Ball Multiball is available at the left scoop for the first Multiball.

If 1-Ball play results before a Jackpot or Double Jackpot is collected, then the mirror lowers for multiball restart (2 Balls). The left scoop is available for restart on the first Multiball only.

17a

Multiball Jackpots

At the start of Multiball, the left ramp is lit for the Jackpot and the right ramp is lit for the Double Jackpot. Each Jackpot may be scored once. If both are collected, then the left & right ramps relight for a 2nd Jackpot or Double Jackpot. If one is collected, the mirror lowers and TOMMY Multiball begins (see item 18). Each Jackpot also adds-a-ball. Jackpot values are increased by 200K/switch (thus 400K/switch for Double).

18

Tommy Multiball

This mode starts after 3 Jackpots have been collected. Mirror shots spell out T-O-M-M-Y & score 20M X Balls-in-play. Once TOMMY is spelled, the left ramp lights for Super Jackpot (250M) & the right ramp lights for Double Super Jackpot (500M). Super Jackpot increases by 1M per switch closure. If either Jackpot is scored, TOMMY Multiball restarts, but with the Blinders (arch) active!

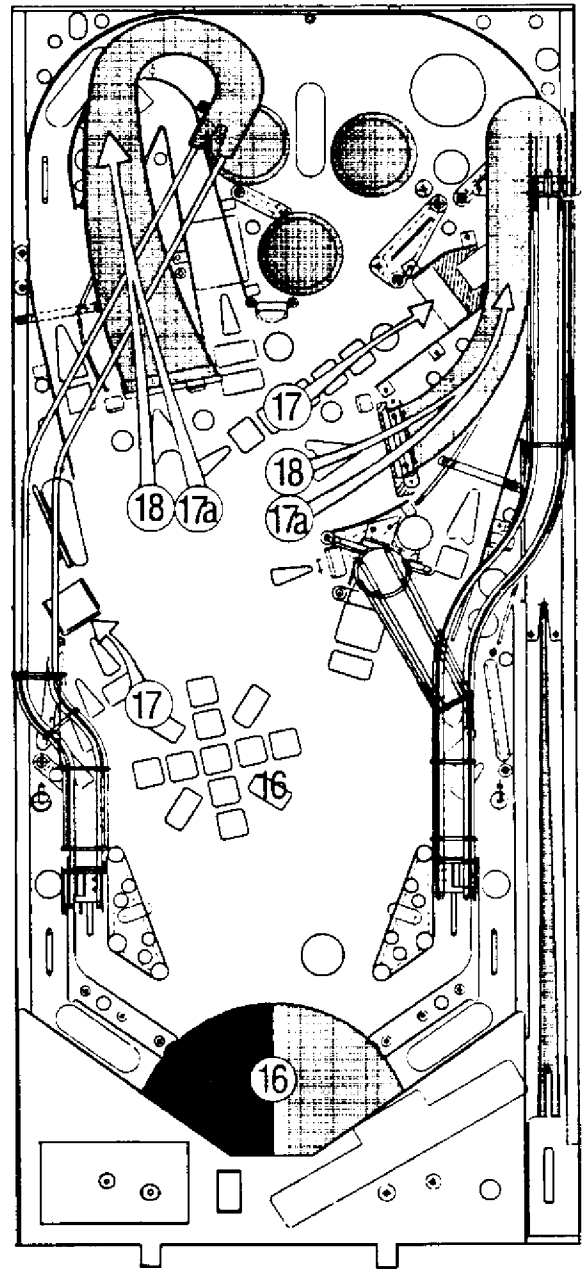

GAME RULES

SINGLE BALL RULES:

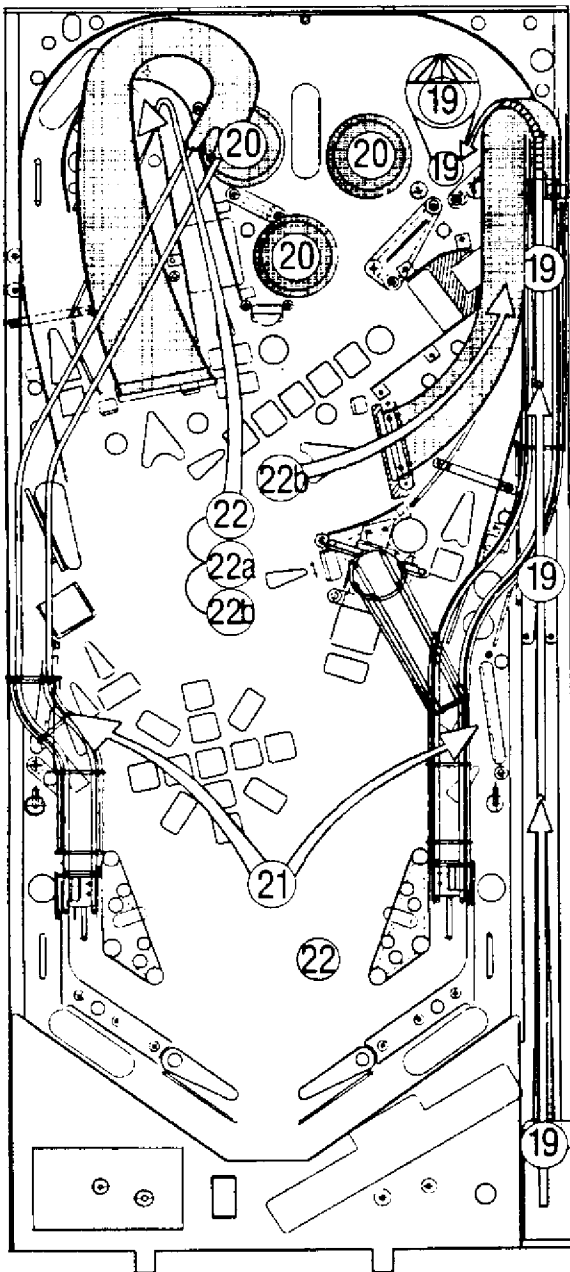

19

Skill Shot

Skill shot is collected at "hole" after successful plunge. Value starts at 10M and can be increased by a) previous successful skill shot(s), and/or b) shooting hole during single ball play. Maximum is 50M.

20

Turbo Bumpers

Turbo Bumpers start at 100K/hit each ball. Each 10 hits, value increases by 100K, up to a maximum of 1M. Bumper value can also increase based on consecutive bumper hits (when the ball stays in bumpers for a long time).

21

3-Bank Targets

Completing a 3-Bank awards 5M, 10M, 15M, 20M. Completion of left bank increases left spinner base by 25K, likewise for right bank and right spinner. Max spinner value is 1M, base is 25K. Left scoop when unlit spots left bank target, captive ball spots right bank target.

22

Genius Award at Eject

Collected at "Eject" hole. Each hit awards a letter. 1st spell "OK" for 5M, then "WOW" for 10M, "GOOD" for 15M, "SUPER" for 20M, and "GENIUS" for 25M. Subsequent spellings of Genius award 30M. Extra ball and Special are available according to percentaging.

22a

Extra Ball at Eject

When lit, collect an extra ball.

22b

Mystery Award at Eject

10 randomly selected awards are available for collection when Mystery is lit via Right Ramp. Awards are given in set order in tournament play. (See item 27).

GAME RULES

Single Ball Rules Continued:

23

Captive Ball

Captive Ball hit advances BonusX: 2X, 3X, 4X, 5X, 6X, 7X = Maximum. Subsequent hits score 10M. BonusX resets at the start of each ball unless held by Mystery Award.

24

Silver Ball Target & Ramp Targets

Unlit ramp targets are worth 500K. The first three Silver Ball hits make a ramp target flash. Hitting flashing ramp targets collects 1M and makes them light. Lit ramp targets score 500K. When all ramp targets are lit, Silver Ball target lights for 20M. (Note: When all ramp targets are flashing, "Silver Ball" hits will light them.)

25

Return Lanes

Return lanes light the opposite spinner for double value for a short time (e.g. Left Return lights the Right Spinner). Also, return lanes may light "Union Jack Collect" for a short time.

26

Left Ramp - Captain Walker Ramp Bomber

Each of the 1st 4 left ramp shots starts the propellers on the bomber on the display. Once the propellers are started a 5th left ramp shot makes the bomber take off. A 20-second timer starts. During this period the spinners drop bombs - 100K+ spinner value for the 1st 10 spins; Add 100K every subsequent 10 spins, with 1M max. spinner value. The left ramp drops a big bomb for 5M. The right ramp drops a REALLY BIG BOMB for 10M. Subsequent Bomber take-offs may require more left ramps.

27

Right Ramp - Light Mystery

"Mystery" lights at "eject" after 2, 5, 8, 11, 16, 22, 29, 37, 46, ..., 99 right ramp shots.

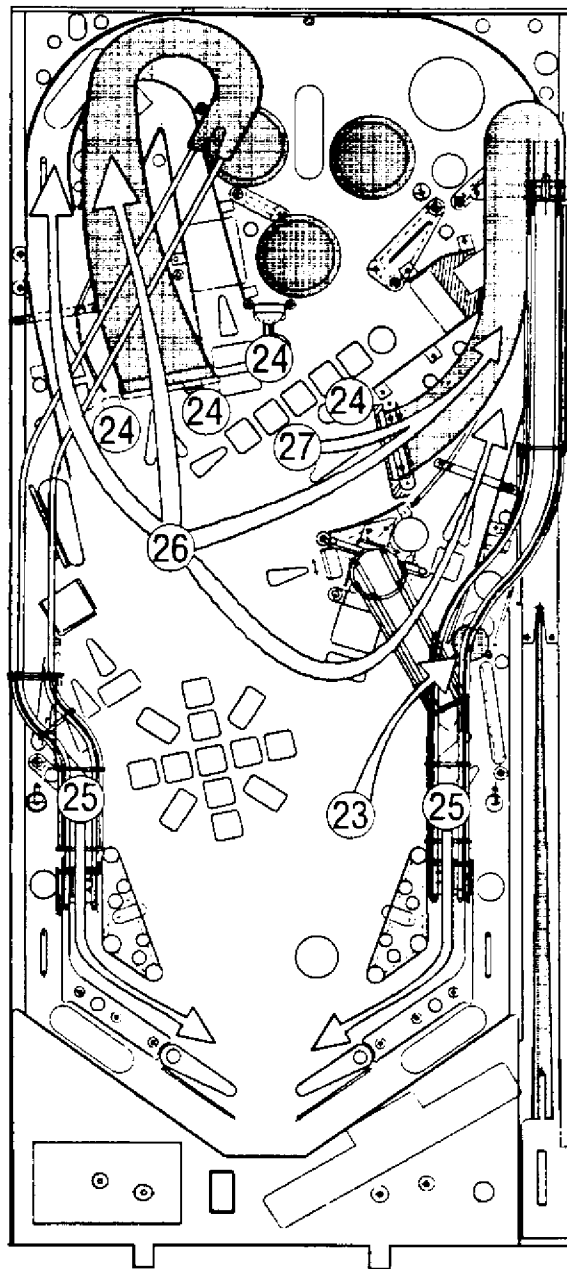

GAME RULES

Single Ball Rules Continued:

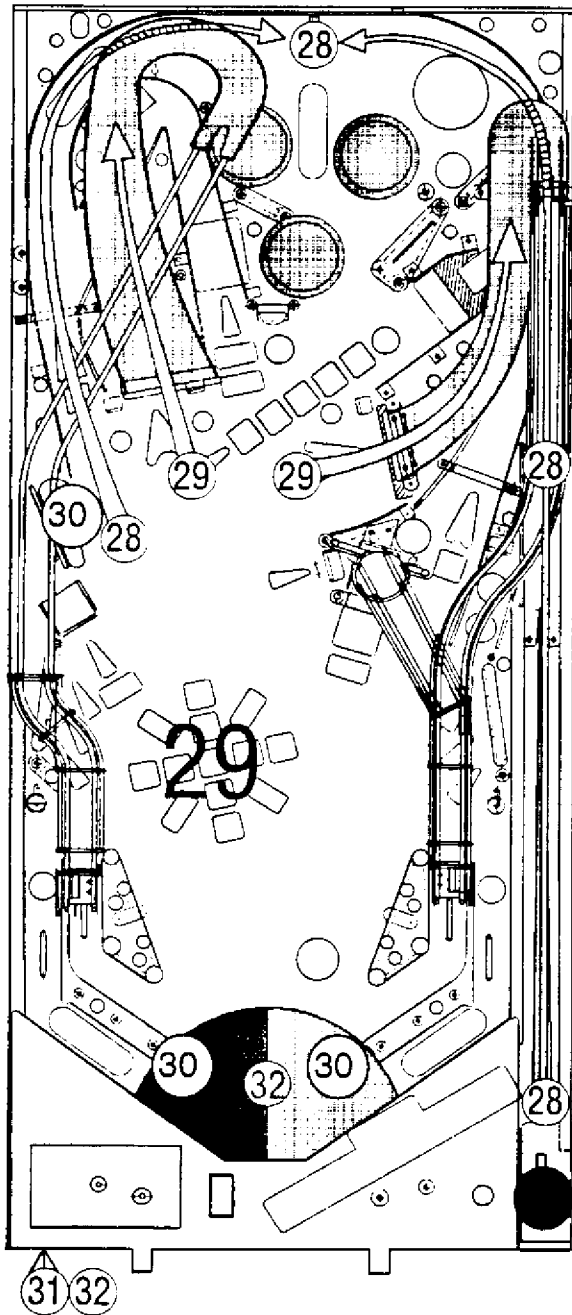

28

Left and Right Orbits

A number of orbits within a set time limit give special awards. The next award is shown on the display when the orbit is shot.

29

Bonus

Bonus = BonusX x [100K x Left Ramps current ball + 200K x Right Ramps current ball + 600K x Union Jacks Collected]

30

Combination Shots

The game features three "3" and "4" shot combos and one "5" shot combo. These combos involve natural sequences of orbits, ramps, and/or the mirror target. Several undocumented difficult combos may also be present.

EXTRA FEATURES:

31

Extra-Ball (EB) Buyin

After game ends, extra ball(s) may be purchased to continue before countdown ends. Cancel buyin with Start Button or flippers.

32

Tommy Shield Game

Pressing the "EXTRA BALL BUTTON" along with "START BUTTON" at the beginning of a game starts a game with the arch active (blinder covering the flippers) **for the whole game! For True Wizards Only!!!** Highscore is recorded separately.

?

Hidden Rules

Like *Tommy*, your amazing journey will yield new discoveries!!

AUDIT FUNCTIONS

GENERAL

There are 64 audit functions provided for accounting purposes and for evaluation of game difficulty adjustments. Audit functions are split into two groups. There are 12 most-used audits (1 through 12) in a 'quick look' group and 54 less-used audits (13 through 64), in an 'Expanded' Group. The various auditing functions are summarized in the **GAME AUDIT TABLE** and, when accessed, are shown on the Dot Matrix Display. The *Audit Number* is shown in the top of the display, the *Description* is shown next and the *Audit Total* in the display. Access and control is provided from switches located on the inside of the coin door.

To access audit functions, open the coin door and make sure that the FORWARD/REVERSE switch is in the FORWARD (up) position. Depress the STEP switch and the display indicates AUDITS & ADJUSTMENTS. This indicates access to audit functions.

With the FORWARD/REVERSE push-button switch still in the FORWARD (up) position, depressing the STEP push-button switch advances through the audit functions one at a time. To review lower-numbered functions, set the forward/reverse push-button switch to the REVERSE (down) position and operate the STEP push-button switch.

To access expanded audits, operate the step push-button until AUDIT 12, EXPAND AUDITS is displayed. Set the choice to YES as indicated in the lower display by depressing the Game Start push-button and then depress the step push-button. The request is installed and Audit 13 is displayed. When you exit audits and adjustments, the Audit 12 setting is returned to off for the next time that a review of audits are required.

Audit totals may be reset to zero using Game Adjustment, **ADJUSTMENT 11, AUDITS RESET**. Game adjustments (1 to 12 and 13 to 57) begin after the last audit function (12 or 64). Once audits functions have been recorded, and if no adjustments are required, you may return the game to the attract mode. If adjustments are required, continue pressing the STEP button until the game adjustments are reached. See Game Adjustments for details.

Audits - 'Quick Look' Functions

Au. #	Audit Name	Audit Definition
Au. 1	Total Paid Credits	The total number of paid credits is displayed.
Au. 2	Free Game Percentage	The Total Free Plays (Audit 25) divided by Total Plays (Audit 26).
Au. 3	Average Ball Time	(In Seconds) The Total Play Time divided by Balls Total (Audit 13)
Au. 4	Average GameTime	The Average Game Time expressed in minutes and seconds.
Au. 5, 6, 7, 8	Coins (Left, Right, Center, & 4th Chute)	These four audit totals are provided to show the amount of coins registered for the LT, RT, CT, & 4th Chute, respectively.
Au. 9	Total Coins	The total number of coins dropped through all 4 coin chutes.
Au. 10	Total Earnings	The total cash value accumulated since the last Factory Restore occurred.
Au. 11	Meter Clicks	Provides the total number of money clicks accumulated, based on the country's lowest coin denomination used for the game credit.
Au. 12	Expand Audits...	(On/Off) This audit permits operator to proceed into expanded audits.

The Who's Tommy Game Audit Table

Item/Description	
1	Total Paid Credits
2	Free Game Percentage
3	Average Ball Time
4	Average Game Time
5	Coins Left
6	Coins Right
7	Coins Center
8	Coins 4th Chute
9	Total Coins
10	Total Earnings
11	Meter Clicks
12	Expand Audits...(On/Off)
13	Balls Total
14	Extra Balls Total
15	Extra Ball Percent
16	Replay 1 Awards
17	Replay 2+ Awards
18	Total Replays
19	Replay Percent
20	Total Specials
21	Special Percent
22	Total Matches
23	High Score (HS) Wins
24	High Score (HS) Percent
25	Total Free Plays
26	Total Plays
27	000.0 - 049.9 Million
28	050.0 - 099.9 Million
29	100.0 - 199.9 Million
30	200.0 - 299.9 Million
31	300.0 - 399.9 Million
32	Over 400 Million

Item/Description	
33	Average Scores
34	Service Credits
35	Proprietary
36	Proprietary
37	Proprietary
38	Total Buyin Games
39	Extra Ball (EB) Buyins
40	EB Buyin Replay Awards
41	EB Buyin HS Awards
42	Drains Left
43	Drains Center
44	Drains Right
45	Slam Tilts
46	Skill Shots
47	Freeze Used
48	Parachute Sneak-Ins
49	Left Ramp
50	Right Ramp
51	Mystery Awarded
52	Proprietary
53	More Time
54	1st Multiball Lit
55	1st Multiball Start (Scoop)
56	1st Multiball Start (Mirror)
57	Multiball Restart Awarded
58	2+ Multiball Start
59	Jackpot
60	Double Jackpot
61	Tommy Multiball Started
62	Tommy Multiball Completed
63	Super Jackpot
64	Double Super Jackpot

Note: This Page Can Be Photo-copied And Used For Field Audit Tracking Performance.

Audits - 'Expanded' Generic Functions

Au.#	Audit Name	Audit Definition
Au. 13	Balls Total	The total of regular and extra balls.
Au. 14	Extra Balls Total	The total number of extra balls awarded.
Au. 15	Extra Balls Percentage	The Extra Balls Total (Au.14) divided by Total Plays (Au. 26).
Au. 16 & 17	Replay 1, 2+ Awards	These audits provide the total awards (credit, extra ball, or audit) for replay level 1 or 2+, respectively.
Au. 18	Total Replays	The total awards (credits, extra balls, or audit only) for exceeding replay score levels.
Au. 19	Replay Percent	The Replay Total awards for exceeding replay score levels, Total Replays (Au. 18) divided by Total Plays (Au. 26).
Au.20	Total Specials	The total awards (credits, extra balls, or scores) for making specials.
Au. 21	Special Percentage	The Total Specials (Au. 20) divided by Total Plays (Au. 26).
Au. 22	Total Matches	The total credits awarded for matching the last two digits of the score with the system-generated Match Number at the end of the game. Percentage of match credits will be adjustable from 0% to 10%, by Adj. 13 if enabled.
Au. 23	High Score Wins	The total credits awarded for exceeding the high-score-to-date scores.
Au. 24	High Score Percent	The High Score Wins (Au. 23) divided by Total Plays (Au. 26).
Au. 25	Total Free Plays	The total free credits for replays, high-score-to-date, specials, and match.
Au. 26	Total Plays	The sum of Total Paid Credits (Au.1) and Total Free Plays (Au. 25). Note that free credits are not recorded in the Audit until they are actually used.
Au. 27	000.0 - 049.9 Million	Provides the total number of games the Player's final score was between 0 and 49,999,990 points.
Au. 28	050.0 - 099.9 Million	Provides the total number of games the Player's final score was between 50,000,000 and 99,999,990 points.
Au. 29	100.0 - 199.9 Million	Provides the total number of games the Player's final score was between 100,000,000 and 199,999,990 points.
Au. 30	200.0 - 299.9 Million	Provides the total number of games the Player's final score was between 200,000,000 and 299,999,990 points.
Au. 31	300.0 - 399.9 Million	Provides the total number of games the Player's final score was between 300,000,000 and 399,999,990 points.
Au. 32	Over 400 Million	Provides the total number of games the Player's final score was over 400,000,000 points.
Au. 33	Average Scores	Provides the Average Score by adding the Final Score of each game to a table and dividing this sum by the Total Plays.
Au. 34	Service Credits	Provides the total number of Service credits added to the game. See <i>Game Diagnostics on page 21 for instructions regarding entry of Service Credits.</i>
Au. 35, 36, 37	Proprietary	Provides information to the game designer to aid in design development (not for consumer use).

Audits - 'Expanded' Generic Functions (cont.)

Au.#	Audit Name	Audit Definition
Au. 38	Total Buyin Games	Provides the number of times a player utilized the Buy-In Feature.
Au. 39	Extra Ball Buyins	Provides the total number of times the Extra Ball Buyin feature was used.
Au. 40	EB Buyin Replay Awards	Provides the total number of replay awards that resulted from the use of the Extra Ball Buyin (Au. 39) feature.
Au. 41	EB Buyin HS Awards	Provides the total number of times in which use of the Extra Ball Buyin feature resulted in a high score.
Au. 42	Drains Left	Provides the number of times the ball drained out the left drain.
Au. 43	Drains Center	Provides the number of times the ball drained out the center drain.
Au. 44	Drains Right	Provides the number of times the ball drained out the right drain.
Au. 45	Slam Tiits	Provides the number of times the Slam Tilt switch was activated.

Audits - 'Expanded' Game Specific Functions

Au.#	Audit Name	Audit Definition
Au. 46	Skill Shot	Provides the total number of Skill Shot awards.
Au. 47	Freeze Used	Provides the total number of times the Freeze feature was used. The Freeze feature is enabled at the start of each ball and is disabled as soon as the ball makes contact with 5 game switches.
Au. 48	Parachute Sneak-Ins	Provides the total number of times a ball entered the parachute hole during regular game play, i.e. when the hole is not lit for a skill shot award.
Au. 49	Left Ramp	Provides the total number of left ramp shots.
Au. 50	Right Ramp	Provides the total number of right ramp shots.
Au. 51	Mystery Awarded	Provides the total number of times the Mystery feature was awarded.
Au. 52	Proprietary	Provides information to the game designer to aid in design development (not for consumer use).
Au. 53	More Time	Provides the total number of times the More Time feature was awarded.
Au. 54	1st Multiball Lit	Provides the total number of times the Multiball feature was enabled once.
Au. 55	1st Multiball Start (Scoop)	Provides the total number of times the Multiball feature was started once via the Left Scoop.
Au. 56	1st Multiball Start (Mirror)	Provides the total number of times the Multiball feature was started once via the Mirror.

Audits - 'Expanded' Game Specific Functions (cont.)

Au.#	Audit Name	Audit Definition
Au. 57	Multiball Restart Awarded	Provides the total number of times the Multiball Restart feature was awarded.
Au. 58	2+ Multiball Start	Provides the total number of times the Multiball feature was awarded two or more times.
Au. 59	Jackpot	Provides the total number of times the Jackpot feature was collected.
Au. 60	Double Jackpot	Provides the total number of times the Double Jackpot feature was collected.
Au. 61	Tommy Multiball Started	Provides the total number of times Tommy Multiball was started.
Au. 62	Tommy Multiball Completed	Provides the total number of times Tommy Multiball was completed.
Au. 63	Super Jackpot	Provides the total number of times the Super Jackpot feature was collected.
Au. 64	Double Super Jackpot	Provides the total number of times the Double Super Jackpot feature was collected.

NOTES

GAME ADJUSTMENTS

GENERAL

There are 57 adjustable functions provided to vary difficulty of play and to periodically reset audits and the high score levels. The various game adjustments are summarized in the **Game Adjustments Table** and, when accessed, are shown on the player score displays. The *Adjustment Number* is shown in the top of the display, the *Description* is shown next, and the setting, in the bottom of the display. Access and control is provided from switches located on the inside of the coin door.

Game adjustments are accessed from the audit mode. With the audits displaying AUDIT 1 and the FORWARD/REVERSE switch in the REVERSE (down) position, depress the STEP switch and ADJUSTMENT 99 is shown at the top of the display, FACTORY RESTORE is shown in the middle of the display, and NO is shown in the bottom of the display. With the audits displaying AUDIT 10 or 99) and the FORWARD/REVERSE switch in the FORWARD (up) position, depress the STEP switch and ADJUSTMENT 1 is shown in the top of the display, REPLAY/MANUAL is shown in the middle of the display, and the setting is shown in the bottom of the display.

With the FORWARD/REVERSE switch in the FORWARD (up) position, depressing the STEP switch advances through the game adjustments one at a time. With it in the REVERSE (down) position, the STEP switch selects lower-numbered adjustments. To rapidly scroll through adjustments, hold the STEP switch depressed. Adjustment values are changed by operating the GAME START push-button. The FORWARD/REVERSE switch setting determines whether the values are increased or decreased. (With the FORWARD/REVERSE switch up, the value increases, with it down, the value decreases). When the STEP switch is depressed the display indicates REQUEST INSTALLED.

REPLAY AND GENERIC FEATURES

Replays may be adjusted either for fixed levels or for a system-adjusted manual percentage of replay awards. Four levels may be selected. Adjustments allow awarding of a credit or an extra ball as each level is exceeded. With the manual percentage feature, if the actual replay percentage is higher or lower than that desired, the game computes new recommended manual percentage score(s). When the coin door is subsequently opened the player displays indicate the recommended level and a sound is made to alert the operator of a potential change. This new level is entered into adjustments simply by pressing the game start push-button. (If the coin door is closed or you enter audits/adjustments or diagnostics, the replay level is not changed.)

Adjustments - 'Replays' (1-6)

Adj.#	Adjustment Name	Adjustment Definition
Adj. 1	Replay - Manual: Replay - Fixed:	Adjust for percentage of awards for replay levels (1% through 50%). Proceed to Adj. 2 and 3 for starting replay levels. Lower the automatic value to 0% and the display will indicate Fixed. Proceed to Adj. 2 and 3 for fixed replay levels.
Adj. 2	Start Replay - Manual	Adjust the starting Replay 1 setting to between 50,000,000 and 9,999,000,000.
Adj. 3	Levels Replay / Level 1, 2, 3 & 4 Replay	Adjust the number of replay levels to be active (1 to 4). Any additional starting replay levels are automatically set to values higher than Replay 1. Adjust Replay 1 level to between 50,000,000 and 9,999,000,000. (Same as Start Replay). If Adj. 3 is set for 2, 3, or 4, adjust Replay 2, 3, or 4 (respectively) level to between 50,000,000 & 9,999,000,000.
Adj. 4	Replay Awards	Set for replays to award: CREDIT, EXTRA BALL, NONE or SPECIAL (When score threshold is achieved, a Playfield Special is lit.
Adj. 5	Limit Freegame	Adjust the max. # of free games that may be accumulated per game; 0-9
Adj. 6	Limit Extra Balls	Adjust the max. # of free games that may be accumulated per game; 1- 9 or OFF.

The Who's Tommy Game Adjustment Table

Adj. No.	Description	Factory Setting	Adj. No.	Description	Factory Setting
1	Replay: Manual/Fixed	10%	32	Attract Music	ON
2	Start Replay	380,000,000	33	Flash Lamps	NORMAL
3	Replay Levels *	01	34	Coils Pulse	NORMAL
4	Replay Awards	CREDIT	35	Proprietary	NO
5	Limit Freegame	03	36	Next Game Promo Message	ON
6	Limit Extra Balls	03	37	Buy-In Type	OFF
7	Game Rules *	MODERATE	38	Restart Game	NO
8	Game Price *	USA7	39	Extra Ball Percentage	25%
9	Reset Coins	NO	40	Volume Control	100%
10	Reset Audits	NO	41	Bill Validator	NO
11	Restore High Scores	NO	42	Tournament Style	NONE
12	Expand Adjustments	NO	43	Mirror Motor	ON
13	Match Percentage	09%	44	Arch Motor	ON
14	Balls Per Game	03	45	Special Memory	YES
15	Tilt Warnings	01	46	Rerace Criterion	EASY
16	Replay Boost	YES	47	Jackpot Criterion	HARD
17	Credits Limit	30	48	Multi-Ball Ready Style	MODERATE
18	High Scores Allowed	YES	49	Extra Ball Memory	YES
19	High Score #1 Awards	03	50	Ramp Memory	YES
20	High Score #2 Awards	01	51	Proprietary	NO
21	High Score #3 Awards	00	52	Software Meter	00
22	High Score #4 Awards	00	53	Location ID Number	0000
23	Default High Score #1	1,000,000,000	54	Game ID Number	0000
24	Default High Score #2	900,000,000	55	Number of Copies Printed	00
25	Default High Score #3	800,000,000	56	Printer Interface	PRESS START TO PRINT
26	Default High Score #4	700,000,000	57	EB Buyin	01
27	Default High Score #5	600,000,000	* Some settings result in Drop-Down Tables Review the following pages which define all of the above adjustments.		
28	Default High Score #6	500,000,000			
29	Reset High Score To Date	700			
30	Free Play	NO			
31	Custom Message	ON	99	Factory Restore	NO

SINGLE-FUNCTION DIFFICULTY ADJUSTMENT (7)

Adj.#	Adjustment Name	Adjustment Definition
-------	-----------------	-----------------------

Adj. 7 **Game Rules** Any one of five INSTALL settings for this adjustment may be activated to automatically select settings for multiple adjustments affecting game difficulty. Use the Start button to choose the difficulty level you require and press the step button to activate the setting. After activation, the individual adjustments may be readjusted if desired. Refer to Install Adjustment Table for details.

Set to EXTRA EASY, EASY, FACTORY, HARD or EXTRA HARD.

(Note: Additional game features not variable by the Expanded Adjustments may also change using this setting.)

INSTALL ADJUSTMENT	ADJ. 7 Extra Easy	ADJ. 7 Easy	ADJ. 7 Moderate	ADJ. 7 Hard	ADJ. 7 Extra Hard
Multi-Ball Ready Style	04	03	02	01	01
Rerace Criterion	04	04	03	00	00
Jackpot Criterion	YES	YES	YES	YES	NO

NOVELTY / 5-BALL/ADD-A-BALL SETTINGS

The following three combinations are recommended for situations where local laws restrict certain game features regarding the use of replays or the number of balls per game:

Novelty Play Rules - Set to establish recommended settings for no free play or extra balls:

Adj.	Adj. Name	Setting	Adj.	Adj. Name	Setting
1	Manual Replay	Fixed	6	Limit Extra Balls	00
2	Start Replay	00	14	Match Percentage	Off
3	Replay Levels	None	20	Hi-Score 1 Awards	03
4	Game Awards	None	21	Hi-Score 2 Awards	01
5	Limit Freegame	00			

5-Ball Play Rules - Set to establish recommended settings for 5-ball play:

Adj.	Adj. Name	Setting	Adj.	Adj. Name	Setting
1	Manual Replay	07%	15	Balls Per Game	05
2	Start Replay	400,000,000	20	Hi-Score 1 Awards	03
3	Replay Levels	01	21	Hi-Score 2 Awards	01
4	Game Awards	Credit			
5	Limit Freegame	03			
6	Limit Extra Balls	03			
14	Match Percentage	04			

Add-A-Ball Settings-To disable awarding of credits and provide awards with an extra ball:

Adj.	Adj. Name	Setting	Adj.	Adj. Name	Setting
4	Game Awards	Extra Ball	19	Hi-Scores Allowed	No
5	Limit Freegame	00	20-23	Hi-Score 1-4	00
14	Match Percentage	Off			

GAME PRICE ADJUSTMENT (8)

There are two methods available for coin switch programming; Standard and Custom. Standard pricing uses a single adjustment (Adj. 8) to select a pricing scheme shown in the **Standard /Custom Pricing Table**. Custom pricing is used to select additional pricing schemes defined by a Drop Down menu .

With Adj. 8 set to **CUSTOM** operating the step button again initiates a drop down menu representing coin switch pulses for the left, right, center and fourth coin slots. The prescribes the number of pulses required for one credit. For example, if *Left Coin Pulses*, was set to 02 and *Coin Switch Pulses Required for 1 Credit*, to 01 a coin in the left slot would produce two credits. Further, if *Left Coin Pulses*, was set to 01 and *Coin Switch Pulses Required for 1 Credit*, to 02, two coins in the left slot would be required for one credit.

Coin Switch Pulses Required for Bonus Credit may be set to post bonus credits when a minimum amount of coins are inserted at one time. For example, if *Left Coin Pulses* was set to 01, *Coin Switch Pulses Required for 1 Credit* to 01 and *Coin Switch Pulses Required for Bonus Credit* to 04, one credit would be posted for each of the first three coins in the left slot and two credits for the fourth coin.

Standard/Custom Pricing - Set for the desired pricing scheme from the Standard Pricing Table as indicated on the dot matrix display. For Custom Pricing, set to **CUSTOM**. When set to CUSTOM, the following adjustments are utilized to tailor each individual coin chute.

Left Coin Switch Pulses - Set the number of pulses registered for closure of the left coin switch; 00 to 99.

Right Coin Switch Pulses - Set the number of pulses registered for closure of the right coin switch; 00 to 99.

Center Coin Switch Pulses - Set the number of pulses registered for closure of the center coin switch; 00 to 99.

4th Coin Switch Pulses - Set the number of pulses registered for closure of the fourth coin switch; 00 to 99.

Coin Switch Pulses Required for 1 Credit - Set the number of coin switch pulses required to post one credit; 00 to 99.

Coin Switch Pulses Required for Bonus Credit- Set the number of coin switch pulses required to award the 1st bonus credit(s); 00 to 99.

Coin Switch Pulses Required for 2nd Bonus Credit- Set the number of coin switch pulses required to award the 2nd bonus credit; 00 to 99.

Credits awarded for 1st Bonus - Set the number of credits awarded for achieving the first Bonus level; 00 to 99.

CUSTOM PRICING TABLE													
Coin Mechs				Adjustments									
Left	Right	Center	4th	<i>Plays/Coins</i>		Left	Right	Mid	4th	Pulses	Pulses	Pulses	Credit
						Pulses	Pulses	Pulses	Pulses	/Credit	/Bonus	/2nd BONUS	/1st BONUS
25c	25c	\$1.00	N/U	1/25c	3/50c	01	01	04	00	01	02	00	01
				1/25c	5/\$1.00	01	01	04	00	01	04	00	01
				1/25c	6/\$1.00	05	05	20	00	04	20	00	01
5SCH	10SCH	10SCH	N/U	1/10SCH		01	02	02	00	02	00	00	00
				1/10SCH	4/30SCH	04	08	08	00	06	00	00	00
10p	£1	50p	20p	1/30p	2/50p	5/£1	01	15	06	02	03	00	00
				1/50p	3/£1	01	15	05	02	05	00	00	00
				1/30p	4/£1	01	12	05	02	03	00	00	00
20c	\$1.00	N/U	N/U	1/60c	2/\$1.00	01	05	00	00	03	05	00	01

STANDARD PRICING TABLE

Adj. 8 Standard Pricing Select	Coin Mechanisms				Pricing Scheme Explained <i>Number of "Plays" for Price Amount Shown</i>			
	Left 1st	Center 2nd	Right 3rd	Right 4th				
USA 1	25¢	\$1	25¢		1/25¢			
USA 2	25¢	\$1	25¢		1/50¢	2/75¢	3/\$1	
USA 3	25¢	\$1	25¢		1/50¢			
USA 4	25¢		25¢		1/50¢			
USA 5	25¢	\$1	25¢		1/50¢	5/\$2		
USA 6	25¢	\$1	25¢		1/50¢	2/*4X25¢*	3/\$1 (bill)	used to promote Bill Validator
USA 7	25¢	\$1	25¢		1/50¢	4/\$1.50	6/\$2	
Austria	5SCH	10SCH	10SCH		1/10SCH	2/15SCH	3/20SCH	
Australia	20¢	\$1	\$2		1/\$1	3/\$2		
Australia 2 **	20¢	\$1	\$2		1/\$1	2/\$2		
Belgium	5f	20f	50f		1/20f	1/50f		
Canada	25¢	25¢	\$1		1/50¢	2/75¢	3/\$1	
Denmark	1Kr	5Kr	10Kr	20Kr	1/3Kr	2/5Kr		
Denmark 2 **	1Kr	5Kr	10Kr	20Kr	1/2Kr	3/5Kr	7/10Kr	
Finland	1Mka	5Mka			1/3Mka	2/5Mka		
France 1	1f	5f	10f	20f	1/3f	2/5f	5/10f	11/20f
France 2	1f	5f	10f	20f	1/5f	3/10f	7/20f	
France 3	1f	5f	10f	20f	1/3f	2/5f	4/10f	9/20f
Germany 1	1DM	2DM	5DM		1/1DM	5/5DM		
Germany 2	1DM	2DM	5DM		1/1DM	6/5DM		
Germany 3	1DM	2DM	5DM		1/2DM	2/3DM	3/4DM	5/5DM
Greece	50dr		100dr		1/50Dr	3/100Dr		
Holland (See Netherlands 2)								
Hungary **	10F	10F	20F		1/20F	3/40F		
Italy 1	500L		500L		1/500L			
Italy 2	500L		500L		1/1000L	3/2000L		
Japan			100¥		1/100¥	3/200¥		
Korea	100Won		100Won		1/100Won			
Netherlands 1	1G	1G	2.5G		1/1G	3/2.5G		
Netherlands 2	1G	2.5G	5G		1/1G	3/2.5G	6/5G	
New Zealand 1	\$1		\$2		1/\$1	2/\$2		
New Zealand 2	\$1		\$2		1/\$1	3/\$2		
Norway 1 **	5Kr		10Kr		1/5Kr	5/20Kr		
Spain	100Pts		500Pts		1/100Pts	6/500Pts		
Sweden 1	1SKR	5SKR	10SKR		1/10SKR	2/15SKR	3/20SKR	
Switzerland 1	1SFR	2SFR	5SFR		1/1SFR	6/5SFR		
Switzerland 2	1SFR	2SFR	5SFR		1/1SFR	3/2SFR	9/5SFR	
UK 1	10p	50p	1£	20p	1/50p	3/1£		
UK 2	10p	50p	1£	20p	1/40p	3/1£		
UK 3	10p	50p	1£	20p	1/50p			
Yugoslavia	5Dur		5Dur		1/5Dur			

*Double Asterisk (**) indicates new setting.*

ADDITIONAL GENERIC FEATURES (9-39)

Adj.#	Adjustment Name	Adjustment Definition
Adj. 9	Reset Coins	When enabled (set to YES) all coin/paid credit totals will be reset to zero when STEP is depressed.
Adj. 10	Reset Audits	When enabled (set to YES) all audit totals except for coins and paid credits will be reset to zero when STEP is depressed.
Adj. 11	Restore High Scores	When enabled (set to YES) the High Score Levels and associated initials will be restored to backup settings when STEP is depressed .
Adj. 12	Expand Adjustments	When set to NO , depressing the STEP push-button advances directly to Adj. 46, FACTORY RESTORE . When set to YES , depressing the STEP push-button sequences through the expanded adjustments. When exiting from expanded adjustments, this function is reset to OFF for the next time that adjustments are required.
Adj. 13	Match Percentage	Set Match percent from 00% to 10% or OFF . At 00% the match display occurs at the end of the game but never awards a credit.
Adj. 14	Balls Per Game	Adjust the number of balls per game; 2 to 5 .
Adj. 15	Tilt Warnings	Adjust the number of plumb bob tilt switch closures before the ball in play is tilted; 1 to 3 or OFF .
Adj. 16	Replay Boost	Set to YES or NO . When set to YES , exceeding a replay will set a temporary replay level for each time a replay level is surpassed. This new level will equal the previous replay level (when the replay was awarded) plus 50 Million for each following game, until the replays have all been played. At this time the previous level is resumed.
Adj. 17	Credits Limit	Adjust the maximum number of credits that may be posted; 4 to 50 .
<p>There are four of the six high score levels with associated player initials that are displayed during the attract mode. This provides a high-score-to-date feature. When players exceed these levels, the player initials may be entered to replace the previous ones. These levels may be adjusted to award credits and to be reset to backup values after a selected number of games.</p>		
Adj. 18	High Scores Allowed	Set to enable or disable the four high score levels; 00 .
Adj. 19	High Scores #1 Awards	Adjust the number of credits awarded for exceeding level 1 (the highest of the four levels); 0 to 4 .
Adj. 20	High Scores #2 Awards	Adjust the number of credits awarded for exceeding level 1; 0 to 3 .
Adj. 21	High Scores #3 Awards	Adjust the number of credits awarded for exceeding level 2; 0 to 2 .
Adj. 22	High Scores #4 Awards	Adjust the number of credits awarded for exceeding level 3; 0 to 1 .
Adj. 23	Default High Score #1	Adjust the score level to which the world record (the highest of the four levels) may be altered. This adjustment is not affected by Adj. 29, Reset High Score To Date , (Factory Reset defaults to 7,500,000).
Adj. 24	Default High Score #2	Adjust the backup score level to which level 1 may be reset.
Adj. 25	Default High Score #3	Adjust the backup score level to which level 2 may be reset.
Adj. 26	Default High Score #4	Adjust the backup score level to which level 3 may be reset.

Additional Generic Features Continued (9-39)

Adj.#	Adjustment Name	Adjustment Definition
Adj. 27	Default High Score #5	Adjust the backup score level to which level 4 may be reset.
Adj. 28	Default High Score #6	Adjust the backup score level to which level 5 may be reset.
Adj. 29	Reset High Score To Date	Adjust the number of games between automatic resets of high score levels to backup settings and ball time averager adjustments; 100 to 900 or OFF (no reset or adjustment).
Adj. 30	Free Play	When set to YES , no coins are required for games.
Adj. 31	Custom Message	When desired, this function is used to establish a custom message periodically displayed during the attract mode. Set the feature to CHANGE using the Credit button and depress STEP . The letter A is indicated in the first position in the display. Vary the letter by operating the left and right flippers. With the desired letter indicated, depress the CREDIT button to lock in the letter and advance to the next character. Repeat this procedure until the desired message is completed in the display. At this time, depress the STEP push-button switch to advance to Adj. 32.
Adj. 32	Attract Music	Set to ON (approximately every 3 minutes) or OFF .
Adj. 33	Flash Lamps	Set to NORMAL, DIM or OFF . When set to NORMAL the Flash Lamps are active, when DIM the Flash Lamps impulse power is reduced by 25% and when OFF the Flash Lamps do not flash.
Adj. 34	Coils Pulse	Set To NORMAL, HARD or SOFT . When HARD the coil pulse power is increased by 12.5% of the normal pulse rate. When set to SOFT the coil pulse power is reduced by 12.5% of the normal pulse rate. These adjustments are provided to compensate for Low Line or High Line voltage conditions where the solenoids appear to kicking too weak or too hard.
Adj. 35	Proprietary	Provides information to the game designer to aid in design development (not for consumer use).
Adj. 36	Next Game Promo Message	Set to ON or OFF . When set to ON , the game, in attract mode will randomly display a short promotion for our next game. When set to OFF , the game in attract mode will not generate any sounds or graphics referring to the next game.
Adj. 37	Buy-in Type	Set to 02 . When set to 02 , the game is set to Extra Ball Buy-in. When set to 01 , the game is set to Game Buy-in. Set to OFF to make Buy-in Type inoperative.
Adj. 38	Restart Game	Set to YES or NO . When set to YES , a new game may be started during any ball after the first ball is completed. (Note-Pressing start during the first ball will add additional players.) When set to NO , The game disables the start button after the first ball until the final ball is in play.
Adj. 39	Extra Ball Percentage	Set from 0 to 50 . Allows the operator to adjust how frequently the Extra Ball feature is made available to the player.

GAME SPECIFIC FEATURES (40-58, 99)

Adj.#	Adjustment Name	Adjustment Definition
Adj. 40	Volume Control	Set to 0, 25, 50, 75 or 100 percent. Allows the operator to adjust the background music volume independently from the normal game sounds.
Adj. 41	Bill Validator	Set to YES or NO . When set to YES , the display, in game attract mode, will show an "Insert Bill Animation". When set to NO , the display, in game attract mode will show "Insert Coin Animation".
Adj. 42	Tournament Style	Set to NONE, PINBALL EXPO, IFPA-PAPA or HOME . This function determines the default conditions to quickly prepare a game for tournament play. When this setting is changed all audits will be reset and all adjustments will be initiated to the particular style selected. The game will then return to game over attract mode, as if a Factory Restore had been performed. NONE - Same as a Factory Reset conditions. IFPA -Straight 50¢ play, no replay, no Extra Ball, no High Scores, 2 Tilt Warnings and No Match. PINBALL EXPO-PAPA - Same as IFPA settings except Free Play is enabled. HOME -Sets game for Free Play, extra ball play, no replay, 10% Match & Ex Ball percent 30%.
Adj. 43	Mirror Motor	Set to ON or OFF . Allows operation of the Mirror Up/Down Motor during certain events in game play.
Adj. 44	Arch Motor	Set to ON or OFF . Allows operation of the Arch Motor (Blinders covering the lower flippers) during certain events in game play.
Adj. 45	Special Memory	Set to YES or NO . When set to YES , the lit 'Shoot for Special' light will be retained in memory from ball to ball for the same player. When set to NO , the lit 'Shoot for Special' light will go out at the end of each ball.
Adj. 46	Rerace Criterion	Set to EXEASY, EASY, MODERATE, HARD or EXHARD . Determines how Multiball can restart.
Adj. 47	Jackpot Criterion	Determines how the Jackpot is lit.
Adj. 48	Multi-Ball Ready Style	Determines how Multiball Ready is achieved.
Adj. 49	Extra Ball Memory	Set to YES or NO . When set to YES , the lit 'Shoot for Extra Ball' light will be retained in memory from ball to ball for the same player. When set to NO , the lit 'Shoot for Extra Ball' light will go out at the end of each ball.
Adj. 50	Ramp Memory	Set to YES or NO . When set to YES , the 'Completed Number of Ramps' will be retained in memory from ball to ball for the same player to achieve set awards. When set to NO , the 'Completed Number of Ramps' will be reset at the end of each ball.
Adj. 51	Proprietary	Provides information to the game designer to aid in design development (not for consumer use).
Adj. 52	Software Meter	Provides the operator with the total number of Meter Clicks.
Adj. 53	Location I.D. Number	0 to 9999 . Allows the operator to assign a location identification number to the audit print-out sheet. (Will not be affected by Factory Restore.)
Adj. 54	Game I.D. Number	0 to 9999 . Allows the operator to assign a game identification number to the Audit print-out sheet. (Will not be affected by Factory Restore.)

Game Specific Features (40-58, 99) Continued

Adj.#	Adjustment Name	Adjustment Definition
Adj. 55	No. of Copies Printed	Provides the operator with the total number of copies that were printed.
Adj. 56	Printer Interface	Allows the operator to print by pressing the Start Button.
Adj. 57	EB Buyin	00, 01 or UNLIMITED. Allows the operator to adjust the number of Extra Ball (EB) Buyins allowed after normal game play.
Adj. 99	Factory Restore	Allows the operator to reset all adjustments to the factory settings.

NOTES

GAME DIAGNOSTICS

The Data East Pinball system provides tests for sounds, digital displays, lamps, switches, and solenoids. Each feature may be tested manually or automatically using the STEP and FORWARD/REVERSE push-button switches inside the coin door and the Game Start push-button switch on the front of the cabinet. The automatic tests may be used for a quick verification of automatic test functions and the manual tests, for troubleshooting.

During game play, activation of switches and operation of coils with associated switches are monitored. If a switch is not made for 50 games it is considered faulty. When operation of a coil should close or open a switch and does not, the coil is considered faulty. In Game Over Attract Mode, faulty switches and coils (if any) are reported (See Tech Alert Description below). Note that reporting of an unused switch does not constitute a problem and that a bad coil could mean that the associated switch requires adjustment.

Wiring to switches, solenoids and controlled lamps uses color-coded wires that basically follows a resistor color-code scheme for the eight rows and eight columns. During the switch tests and during the discrete lamp test, identification of the color of the row and column wires are indicated in the Dot Matrix Display. For example, making the right coin switch during the Switch Test results in the switch functional name (RIGHT COIN), the row (WHT-YEL) and column (GRN-BRN) wire color codes, and the switch number are shown in the display.

0	BLK = BLACK	3	ORN = ORANGE	6	BLU = BLUE
1	BRN = BROWN	4	YEL = YELLOW	7	VIO = VIOLET
2	RED = RED	5	GRN = GREEN	8	GRY = GREY
				9	WHT = WHITE

Additional Abbreviations/Acronyms Used:

X	Times	P/F	Playfield	PPB	Playfield Power Board
LT	Left	S-U	Stand-Up	SSFB	Solid State Flipper Board
RT	Right	AU.	Audit(s)	PS	Power Supply Board
BOT	Bottom	Adj.	Adjustments	SMB	Shaker Motor Board
MID	Middle	G.I.	General Illumination	Bd.	Board
CT	Center	R/O	Roll-Over	N.C.	Normally Closed

Entering Diagnostics

With the game in the game-over mode, open the coin door and make sure that the FORWARD/REVERSE push-button switch is set to REVERSE (down) and depress the STEP push-button switch. The Player displays will show the tollfree Customer Service number 1-800-KICKERS, that is 1-800-542-5377 (U.S. including Illinois) and the toll number (708) 345-7700 (Outside the United States). This indicates entry into game diagnostics.

Service Credits

With the phone number displayed depress the STEP push-button switch. The game now gives the technician the option of adding 1 to 5 service credits. These credits allow the technician to test-play the game without adding any counts to the coin audits (Au. 01 & Au. 05 - 08). When the message appears, press and hold the Game Start pushbutton until the desired number of credits are shown on the display. Then press the step button again to add these credits to the game and enter Tech Alert. If no Service Credits are desired, press the step button with the initial message displayed.

Tech Alert

The display will now indicate if there are any faulty switches (i.e., Switches that are normally closed but remain open or open switches that have not been closed (activated) in 50 games.

Easy Trough Clear

Pressing the step button again displays the EASY TROUGH CLEAR message and instructs the player to operate either flipper button to easily remove the balls from the trough. This is provided, to allow the technician a simple method of removing the balls from the trough prior to entering the Active Switch Test, thereby reducing the number of switches closed. Also, test functionality of trough, ensure proper trough operation.

Burn-In Minutes

Pressing the step button while in Tech Alert mode will step game into Burn-in Mode (Factory use). At this stage pressing the game start button will cause the game to exercise all CPU I/O functions. This is provided to constantly exercise sounds, solenoids, etc...

To stop the test press the start button again. Cumulative Burn-In minutes will be displayed. To reset Burn-In minutes to 00, you must perform a Audit Reset, Adj. 10 or a Factory Restore, Adj. 99.

Sound Tests

The Data East Pinball sound system produces true digital stereo sound on left and right speakers and mono on a center speaker. During Sound tests, the bottom display shows the sound board circuit under test and the corresponding sounds are selected by operating the left and right flipper buttons to choose the circuit to be tested. Now press the start button to initiate the sound. Refer to the Sound Test Chart for the sound circuits displayed and the sounds produced.

The sound functions allow verification that all channels are functioning properly and that the speaker connections are correct. Speaker Phase Testing procedures follow for checking speaker connections.

SOUND TEST CHART

Auto/Manual Tests	Sounds Produced
LEFT SPEAKER	Left Sine
CENTER SPEAKER	Center Sine
RIGHT SPEAKER	Right Sine
VOICE ROM1 (Loc U17)	Speech 1: "Wizard Mode!"
VOICE ROM2 (Loc U21)	Speech 2: "There's a Doctor!"
VOICE ROM3 (Loc U36)	Speech 3: "Acid Queen!"
VOICE ROM4 (Loc U37)	Speech 4: "Captain Walker!"
MUSIC TEST (Sound ROM, Loc U7)	Level 1-3 Music

Speaker Phase Testing

Connections to each of the three speakers are polarized and each must be connected appropriately for the best quality sound. If one speaker has the positive and negative connections reversed with respect to the other two, bass frequencies will not be produced properly and the overall sound quality will be poor.

To test for proper speaker phasing, use the sound test to cycle through the Left, Center, and Right Sine functions. If the Center Sine produces more volume and bass than the Left and Right Sines, the speakers are connected properly. If it produces the same or less, one speaker is connected improperly. To isolate and correct reversed speaker connections, one of two methods may be used.

1. Check each speaker for polarity markings. If the speakers have polarity markings, verify that the single-color wire (BLK, YEL or RED) is connected to the negative (-) terminal.
2. Disconnect the speaker output connector from the Sound Board and connect a 1.5-volt battery across each speaker pair one at a time while observing the speakers. Make sure the positive battery terminal is connected to the positive lead (CN1- Pin 1, 3 or 6) each time. As the connection is made, check speaker cone movement; proper connections are indicated by outward movement.

Digital Display Test

The Digital display utilizes a Dot Matrix Display Control board mounted in piggyback fashion to the display driver Board. The purpose behind this board is to provide more information (32 X 128 Dots) to the operator as well as displaying graphics to the player.

The board is controlled by a 68B09E microprocessor and it's personality ROMs (Unique to the Game) . It receives Data, Reset & Clock information from the CPU Board via the ribbon cable and sends back multiple Status and Busy signals to the CPU . This is to insure synchronized communication between the CPU and the Display Controller board.

The Drivers for the rows and columns are provided on 4 surface mounted integrated circuits on the Display driver board.

Dot Matrix Display Test

To enter Dot Matrix Display Test, operate the STEP push-button switch from the Sound Manual test. The display will immediately illuminate one vertical column of dots, turning it off and illuminating the next column, until each column has been individually lit, while the other columns are off. It will make one pass. The display will then illuminate the top horizontal row of dots, and test by lighting the row of the display, then turning it off and illuminating the next row, until each row has been individually lit, while the other rows are off. The test will then illuminate all the dots in the display, except for one column. It will cycle this blank column from left to right for one pass. The display will then again illuminate all the dots except for the top row, and then turning it on and blanking the next row, until each row has been individually blanked, while the other rows are on. It will cycle this blank row for one pass. The next test begins with every other dot lit, in both the rows and columns. These dots then go out, and the unlit dots light, resulting in an alternating checkerboard pattern for approximately 4 seconds. The test will repeat these cycles indefinitely until advanced to the next test or until the power is removed. (Please Note- these tests may be interrupted at any time by operating the STEP push-button switch to advance to the next test.)

Mirror Up & Down Test

This game has a feature which lowers a Target Switch (Mirror) to allow a shot to the Vertical Up Kicker (VUK) below the playfield. The motor on this mechanism is controlled by a relay driven by Q23 on the CPU and there are 2 Limit Switches (Mirror Motor Up & Mirror Motor Down) used by the CPU to determine the status of the Mirror Motor.

After entering this test, press and hold the game's Start Button. This will cause the relay to energize as long as the Start Button is depressed. At the same time you will notice that the switch status (ON & OFF) will be indicated in the Dot Matrix Display (Mirror Up & Down). The appropriate switch should be closed just prior to the limit of the Mirror Motor Mechanism and both switches should not be closed (ON) at the same time.

This test is located before the Switch Tests so the technician can move the mechanism until both switches read OFF. This will help eliminate erroneous readings while trying to trace a problem during the Active Switch Test.

Arch Motor Test

This game has a feature which covers the lower flippers, called the Blinder. The motor on this mechanism is controlled by the Servo Board, which receives its' data from the CPU Board.

After entering this test, press and hold the game's Start Button which engages the Blinder Mechanism , releasing the Start Button will disengage the Blinder Mechanism. Refer to the Blinder Schematic/Troubleshooting Section for further information.

SWITCH TESTS

Switches are configured in an 8 x 8 matrix of columns (switch drives) and rows (switch returns) with up to 64 switches possible. The switch tests include three parts; switch test, active switches, and bad switches. Row and column wire colors are indicated in each test using corresponding resistor color code numbers.

Switch Test

From the Laser Kick test, operate STEP push-button switch. The display should indicate SWITCH TEST. Close each switch and observe the displays. The display will indicate the switch name, the display indicates the row and column wire colors, and indicates the switch number. When a switch is released, the name and number disappear until another switch is closed or the test is exited.

Active Switches

Operate the STEP push-button switch from the Switch Test. The display will indicate ACTIVE SWITCHES. If any switches are stuck closed (or made from the presence of a ball), the display sequences through switch names, and indicates the row and column wire colors, and the switch numbers are indicated in the display. This cycle continues until all switches are cleared or until the STEP push-button switch is depressed.

SWITCH MATRIX CHART

Column Row	1 Q55 GRN-BRN CN8-1	2 Q54 GRN-RED CN8-2	3 Q53 GRN-ORN CN8-3	4 Q52 GRN-YEL CN8-4	5 Q51 GRN-BLK CN8-5	6 Q50 GRN-BLU CN8-7	7 Q49 GRN-VIO CN8-8	8 Q48 GRN-GRY CN8-9
1 WHT-BRN CN10-9	Plumb Tilt 1	Ball Trough #1 LT 9	Left Slingshot 17	LT 3-Bank S-U BOT 25	RT 3-Bank S-U Top 33	Mirror Trough 41	Left Turbo Bumper 49	Left Ramp Enter 57
2 WHT-RED CN10-8	4th Coin 2	Ball Trough #2 10	Right Slingshot 18	LT 3-Bank S-U MID 26	RT 3-Bank S-U MID 34	Skill Trough 42	Center Turbo Bumper	Left Ramp Exit 58
3 WHT-ORN CN10-7	Credit Button 3	Ball Trough #3 11	VUK 19	LT 3-Bank S-U Top 27	RT 3-Bank S-U BOT 35	Captive Ball 43	RT Turbo Bumper 51	Not Used 59
4 WHT-YEL CN10-6	Right Coin 4	Ball Trough #4 12	LT Ramp S-U LT 20	Mirror Up 28	Left Return Lane 36	Not Used 44	Not Used 52	Not Used 60
5 WHT-GRN CN10-5	Center Coin 5	Ball Trough #5 13	LT Ramp S-U RT 21	Top Left Rollover 29	RT Return Lane 37	Not Used 45	Not Used 53	Not Used 61
6 WHT-BLU CN10-3	Left Coin 6	Ball Trough #6 14	Right RampS-U 22	Right Ramp Enter 30	Middle Stand-Up 38	Not Used 46	Not Used 54	Right Ramp Exit 62
7 WHT-VIO CN10-2	Slam Tilt 7	Ball Trough #7 RT 15	Left Scoop 23	Mirror Down 31	Left Spinner 39	Eject 47	Left Outlane 55	Left Flipper 63
8 WHT-GRY CN10-1	Extra Ball Button 8	Shooter Lane 16	Silver Ball Target 24	Mirror Target 32	Right Spinner 40	Top Right Rollover 48	Right Outlane 56	Right Flipper 64

Switch Matrix Locations, Descriptions & Switch Part Numbers

Switch Matrix No. & Description	Part No.
01* Plumb Tilt	See Cabinet
02* 4th Coin (On Coin Door)	---
03* Credit Button (Left of Coin Door)	500-5097-02
04* Right Coin (On Coin Door)	180-5024-00
05* Center Coin (On Coin Door)	180-5024-00
06* Left Coin (On Coin Door)	180-5024-00
07* Slam Tilt	180-5022-00
08* Extra Ball Button (Under 03)	
09 Ball Trough #1 Left	180-5119-00
10 Ball Trough #2	180-5119-00
11 Ball Trough #3	180-5119-00

Switch Matrix No. & Description	Part No.
12 Ball Trough #4	180-5119-00
13 Ball Trough #5	180-5119-00
14 Ball Trough #6	180-5119-00
15 Ball Trough #7 Right	180-5118-00
16 Shooter Lane	180-5100-01
17 Left Slingshot	180-5023-00
18 Right Slingshot	180-5023-00
19 VUK Microswitch	180-5064-00
20 Left Ramp Stand-Up LEFT	515-5967-08
21 Left Ramp Stand-Up RIGHT	515-5967-08
22 Right Ramp Stand-Up	515-5967-08
23 Left Scoop	180-5116-00
24 Silver Ball Target	515-5932-00
25 Left 3-Bank Stand-Up Bottom	515-5966-06
26 Left 3-Bank Stand-Up Middle	515-5966-07
27 Left 3-Bank Stand-Up Top	515-5966-03
28 Mirror Up	180-5052-00
29 Top Left Rollover	500-5706-00
30 Right Ramp Enter	180-5090-00
31 Mirror Down	180-5052-00
32 Mirror Target	180-5083-00
33 Right 3-Bank Stand-Up Top	515-5966-03
34 Right 3-Bank Stand-Up Middle	515-5966-07
35 Right 3-Bank Stand-Up Bottom	515-5966-06
36 Left Return Lane	500-5707-00
37 Right Return Lane	500-5706-00
38 Middle Stand-Up	515-5966-08
39 Left Spinner	180-5010-04
40 Right Spinner	180-5010-04
41** Mirror Trough	180-5057-00
42** Skill Trough	180-5057-00
43 Captive Ball (Target Switch)	180-5114-08
44 Not Used	---
45 Not Used	---
46 Not Used	---
47 Eject (Micro Switch)	180-5027-01
48 Top Right Rollover	500-5706-00
49 Left Turbo Bumper	180-5015-01
50 Center Turbo Bumper	180-5015-01
51 Right Turbo Bumper	180-5015-01
52 Not Used	---
53 Not Used	---
54 Not Used	---
55 Left Outlane	500-5706-00
56 Right Outlane	500-5706-00
57 Left Ramp Enter	180-5090-00
58 Left Ramp Exit	180-5093-00
59 Not Used	---
60 Not Used	---
61 Not Used	---
62 Right Ramp Exit	180-5093-00
63* Left Flipper (Cabinet)	180-5124-00
64* Right Flipper (Cabinet)	180-5124-00

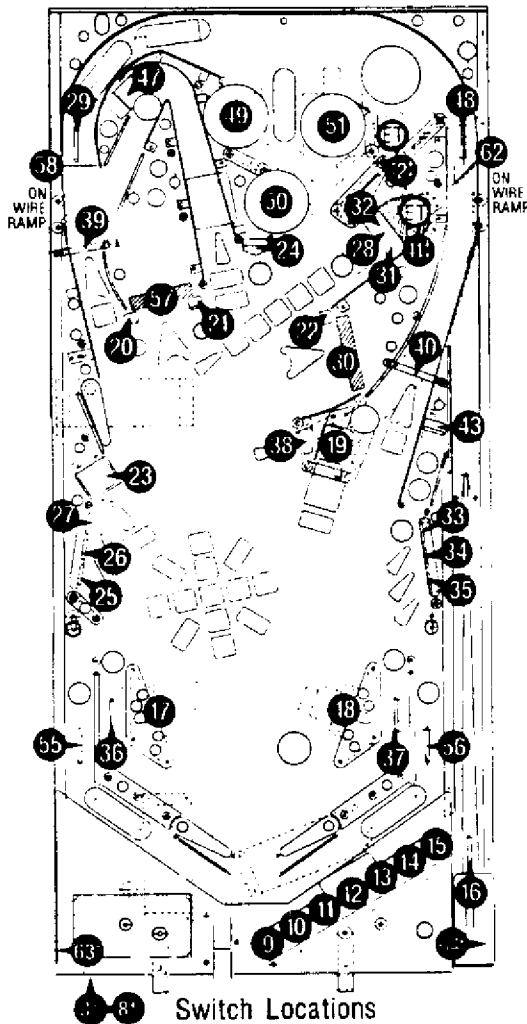

- * Location - In Cabinet
- ** Location - Under Playfield
- ET Enter Trough (Mirror & Skill)

NOTE: RAMPS ARE NOT SHOWN ABOVE

LAMP TESTS

Controlled lamps are configured in an 8 x 8 matrix of columns (lamp drives) and rows (lamp returns) with up to 64 lamps possible. The lamp tests include four parts, all lamps, lamp return (row), lamp drive (column), and discrete (individual) lamps. Row and column wire colors are indicated in the discrete lamp test using corresponding resistor color code numbers.

All Lamps

From the Active Switch test, operate the STEP push-button switch. The dot matrix display will indicate ALL LAMPS and all controlled lamps will light.

Lamp Returns

From the ALL LAMPS test, depress the STEP push-button switch. The display indicates LAMP RETURNS, indicates wire color and the LAMP RETURN driver transistor. All controlled lamps in row 1 should be lit. Operating the Game Start push-button switch cycles through each of the rows separately.

Lamp Drives

From the LAMP RETURNS test, depress the STEP push-button switch. The display will indicate LAMP COLUMNS, wire color and the LAMP DRIVES driver transistor. All controlled lamps in column 1 should be lit. Operating the Game Start push-button switch, cycles through each of the columns separately.

Single Lamp

From the LAMP DRIVES test, depress the STEP push-button switch. The display will indicate the lamp name. The display indicates the row and column wire colors and the lamp matrix number. Lamp 01 should light. With the FORWARD/REVERSE push-button switch in the FORWARD (up) position, operating the Game Start push-button switch selects higher-numbered lamps; with it in the REVERSE (down) position, Game Start selects lower-numbered lamps.

LAMP MATRIX CHART

Column Row	1 Q71 YEL-BRN CN7-1	2 Q70 YEL-RED CN7-2	3 Q69 YEL-ORN CN7-3	4 Q68 YEL-BLK CN7-4	5 Q67 YEL-GRN CN7-6	6 Q66 YEL-BLU CN7-7	7 Q65 YEL-VIO CN7-8	8 Q64 YEL-GRY CN7-9
1 Q72 RED-BRN CN6-1	Insert X2 (M)OMMY 1	Skill Shot 9	Jackpot 17	LT 3-Bank S-U BOT 25	RT 3-Bank S-U Top 33	P/F (M)OMMY 41	Left Turbo Bumper 49	Acid Queen LT 57
2 Q73 RED-BLK CN6-2	Grid: Christmas 2	Insert X2 (O)MMY 10	Double Jackpot 18	LT 3-Bank S-U MID 26	RT 3-Bank S-U MID 34	P/F (O)MMY 41	CT Turbo Bumper 50	Acid Queen CT 58
3 Q74 RED-ORN CN6-3	Grid: Cousin Kevin 3	Grid: Smash the Mirror 11	Insert X2 TO(M)MY 19	LT 3-Bank S-U Top 27	RT 3-Bank S-U BOT 35	P/F TO(M)MY 43	RT Turbo Bumper 51	Acid Queen RT 59
4 Q75 RED-YEL CN6-5	Grid: Holiday Camp 4	Grid: Fiddle About 12	LT Ramp S-U LT 20	Insert X2 TOM(M)Y 28	Mystery 36	P/F TOM(M)Y 44	Spinner Bonus RT 52	Sally Simp- son LT 60
5 Q76 RED-GRN CN6-6	Grid: Lite Extra Ball 5	Grid: Acid Queen 13	LT Ramp S-U RT 21	Spinner Bonus LT 29	Insert X2 TOMM(Y) 37	P/F TOMM(Y) 45	Lite Union Jack RT 53	Sally Simp- son RT 61
6 Q77 RED-BLU CN6-7	Grid: Silver Ball 6	Grid: There's A Doctor 14	RT Ramp S-U Top 22	Extra Ball 30	More Time 38	Outlanes X2 46	Holiday Camp 54	Scoop Multiball 62
7 Q78 RED-VIO CN6-8	Grid: Captain Walker 7	Grid: Tommy Scoring 15	Extra Ball Button 23	Lite Union Jack LT 31	Captain Walker LT 39	Mirror Multiball 47	Return Lanes X2 55	Collect Union Jack 63
8 Q79 RED-GRY CN6-9	Grid: Wizard 8	Grid: Sally Simp- son 16	Silver Ball 24	Genius 32	Captain Walker RT 40	Shoot Again 48	Airplane 56	Credit Button 64

Lamp Matrix Location and Descriptions

Lamp Matrix No. & Description	
01**	...T (Insert X2)
02	Grid: Christmas
03	Grid: Cousin Kevin
04	Grid: Holiday Camp
05	Grid: Lite Extra Ball
06	Grid: Silver Ball
07	Grid: Captain Walker
08	Grid: Wizard
09	Skill Shot
10**	...O (Insert X2)
11	Grid: Smash the Mirror

Lamp Matrix No. & Description	
12	Grid: Fiddle About
13	Grid: Acid Queen
14	Grid: There's A Doctor
15	Grid: Tommy Scoring
16	Grid: Sally Simpson
17	Jackpot
18	Double Jackpot
19**	...M (Insert X2)
20	Left Ramp Stand-Up Left
21	Left Ramp Stand-Up Right
22	Left Ramp Stand-Up Top

Lamp Matrix No. & Description	
23*	Extra Ball Button (Cabinet)
24	Silver Ball
25	Left 3-Bank Stand-Up Bottom
26	Left 3-Bank Stand-Up Middle
27	Left 3-Bank Stand-Up Top
28**	...M (Insert X2)
29	Spinner Bonus Left
30	Extra Ball
31	Light Union Jack Left (Spinner)
32	Genius
33	Right 3-Bank Stand-Up Top
34	Right 3-Bank S.U. Middle
35	Right 3-Bank S.U. Bottom
36	Mystery
37**	...Y (Insert X2)
38	More Time
39	Captain Walker LT (See Note 1)
40	Captain Walker RT (See Note 1)
41	...T (Playfield)
42	...O (Playfield)
43	...M (Playfield)
44	...M (Playfield)
45	...Y (Playfield)
46	Outlanes X2
47	Mirror Multiball
48	Shoot Again
49	Left Turbo Bumper
50	Center Turbo Bumper
51	Right Turbo Bumper
52	Spinner Bonus
53	Lite Union Jack RT (Spinner)
54	Holiday Camp
55	Return Lanes X2
56	Airplane (See Note 2)
57	Acid Queen Left
58	Acid Queen Center
59	Acid Queen Right
60	Sally Simpson LT (See Note 1)
61	Sally Simpson RT (See Note 1)
62	Scoop Multiball
63	Collect Union Jack
64*	Credit Button (Cabinet)

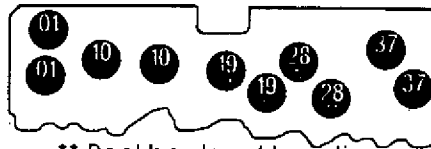

** Backbox Insert Locations

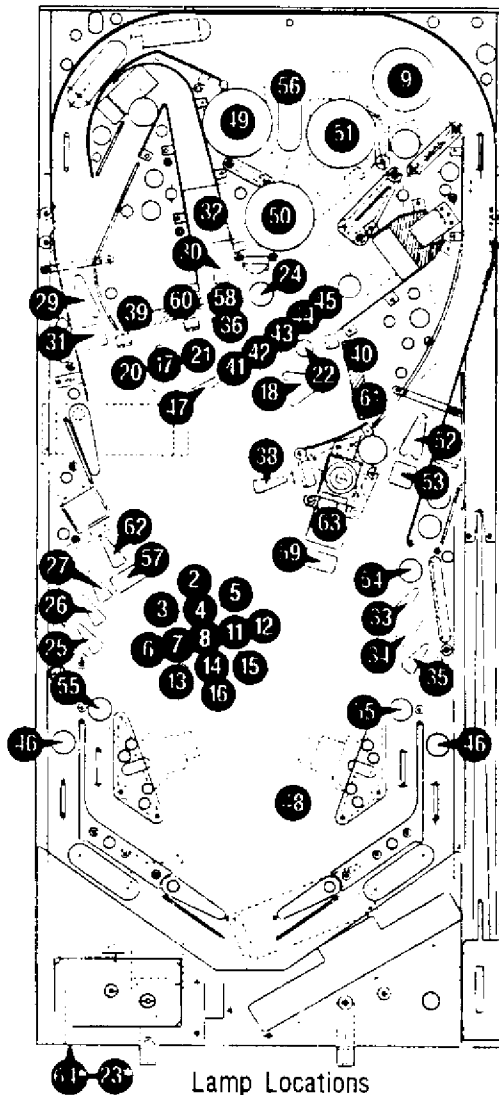

Lamp Locations

Notes:

- * Location - In Cabinet
- ** Location - Backbox (Insert)
- 1 RAMPS ARE NOT SHOWN
- 2 AIRPLANE IS NOT SHOWN
- 3 General Illumination (G.I.) Lamps NOT SHOWN
- 4 For Bulb Type & PNs, See Page 43

FLASH LAMP / COIL TESTS

Twenty-Two regular (pulsed under microprocessor control) coil drivers are provided to switch ground to coils. The Left/Right relay is used in conjunction with drives 1 through 8 to switch +32 volts between coils or flash lamps; these sets are termed "left" and "right". This relay is located on the PPB board which provides isolation diodes and current limiting resistors. This effectively provides 29 regular coils.

Flash Lamp	From the Single Lamp test, depress the STEP push-button switch. All Flash lamps will fire randomly. This allows the Technician to easily spot any burned out bulbs and replace them without stepping through the tests below.
Automatic Test	From the Flash Lamps test, depress the STEP push-button switch. The dot matrix display will indicate ALL COILS. The test pulses each regular solenoid or flash lamp sequentially with the coil/flash lamp names and the wire colors indicated in the display.
Select Coil	From the Coil Test, depress the STEP push-button switch. The display will indicate SELECT COIL and then the name of 1st drive and the wire colors. Operate either Flipper push-button switch to select the coil or flash lamp to be tested. With the desired drive number indicated in the Player 4 display, depress the START push-button switch to cause it to be pulsed repeatedly.
Return To Game Over	From the Select Coil test, depress the STEP push-button switch once. The game returns to the game-over mode.

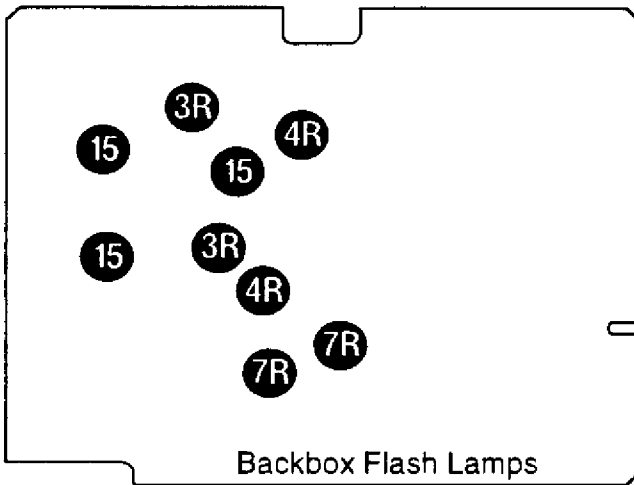

1L	6-Ball Ass'y Lockout	8R	Hot Dogs
1R	Bot. Arch Lt. & Rt.	09	NOT USED
2L	Ball Eject	10	Left/Right Relay
2R	Upper Rt. Corner	11	G.I. Relay
3L	Auto Ball Launch	12	Top Diverter
3R	Left Scoop	13	Airplane Motor
4L	VUK	14	Mirror Motor Relay
4R	Upper Right	15	Tommy Flash
5L	Left Scoop	16	NOT USED
5R	Turbo Hot Dog	17	Top Left Turbo
6L	Eject	18	Top Center Turbo
6R	Back Panel	19	Top Right Turbo
7L	NOT USED	20	Left Slingshot
7R	Lower Rt. Hot Dog	21	Right Slingshot
8L	Knocker	22	NOT USED

Note: Shaded areas not shown on Diagrams.

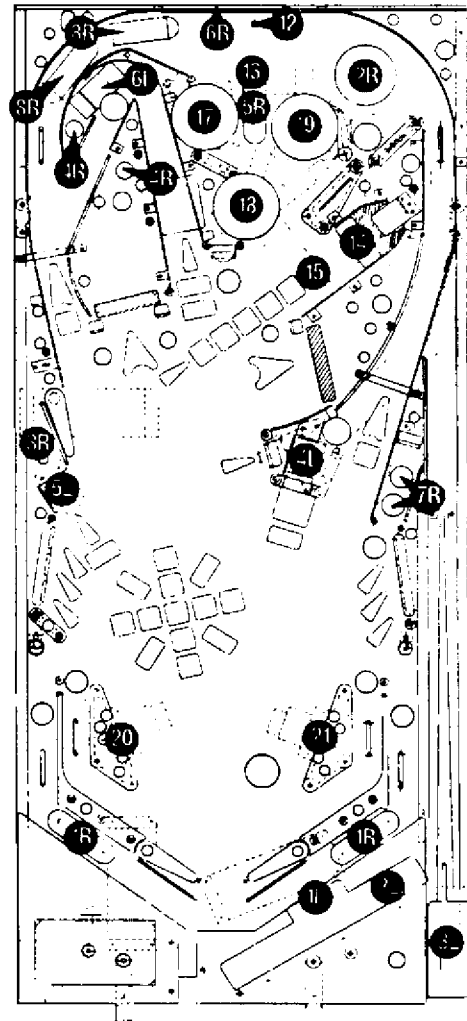

Switched, CPU Controlled Auxillary & Constant Power Solenoids

GRY-BRN through GRY-BLK

Coil No.	Coil or Flashlamp Description	Drive Transistor (D.T.)	On Which Board?	D.T. Control Line	D.T. Control Line Connect	Power Line	Power Line Connection	Power Description	Coil or Flash Type
1L	Coil: 6-Ball Ass'y Lockout	Q46	CPU	VIO-BRN	PPB J 2-10	BRN	PPB J 6-3	32v L	25-1240
1R	Flashlamp: X4 By Bottom Arch Lt & Right			BLK-BRN	PPB J 9-5	ORG	PPB J 6-4, 5	32v R	Bulb #89
2L	Coil: Ball Elect	Q45	CPU	VIO-RED	PPB J 2-9	BRN	PPB J 6-3	32v L	23-800
2R	Flashlamp: X4 Upper Right Corner			BLK-RED	PPB J 9-6	ORG	PPB J 6-4, 5	32v R	Bulb #89
3L	Coil: Auto Ball Launch	Q44	CPU	VIO-ORG	PPB J 9-2	YEL/VIO	PPB J 7-8, 9	32v L	22-600
3R	Flashlamp: X2 Left Scoop			BLK-ORG	PPB J 9-7	ORG	PPB J 6-4, 5	32v R	Bulb #89
4L	Coil: VUK	Q43	CPU	VIO-YEL	PPB J 9-4	BRN/VIO	PPB J 7-8, 9	32v L	23-800
4R	Flashlamp: X2 Upper Right			BLK-YEL	PPB J 9-8	ORG	PPB J 6-4, 5	32v R	Bulb #89
5L	Coil: Left Scoop	Q42	CPU	VIO-GRN	PPB J 2-6	BRN	PPB J 6-3	32v L	23-800
5R	Flashlamp: X4 Turbo Hot Dog			BLK-GRN	PPB J 9-9	ORG	PPB J 6-4, 5	32v R	Bulb #89
6L	Coil: Elect	Q41	CPU	VIO-BLU	PPB J 2-5	BRN	PPB J 6-3	32v L	24-940
6R	Flashlamp: X4 Back Panel			BLK-BLU	PPB J 9-10	ORG	PPB J 6-4, 5	32v R	Bulb #89
7L	Coil: Not Used	Q40	CPU	Not Used	PPB J 2-3	Not Used	---	---	Not Used
7R	Flashlamp: X2 Lower Right Hot Dog			BLK-VIO	PPB J 9-11	ORG	PPB J 6-4, 5	32v R	Bulb #89
8L	Coil: Knocker	Q39	CPU	VIO-GRY	PPB J 2-2	BRN	PPB J 6-3	32v L	23-800
8R	Flashlamp: X4 Hot Dogs			BLK-GRY	PPB J 9-12	ORG	PPB J 6-4, 5	32v R	Bulb #89
09	Coil: Shaker Motor TIP 36C	Q1	PPB	BRN-BLK	PPB J 9-12	GRY/GRN	PS CN 3-10	9v AC	---
10	Coil: Left & Right Relay	Q29	CPU	BRN-RED	CPU CN 12-2	RED/WHT	PS CN 3-5	32v	24v DC 10A OPDT
11	Coil: G.I. Relay	Q28	CPU	BRN-ORG	CPU CN 12-4	RED	PS CN 3-6, 7, 8	32v	
12	Coil: Top Diverter	Q27	CPU	BRY-YEL	CPU CN 12-5	RED	PS CN 3-6, 7, 7/8	32v	27-1500
13	Coil: Airplane Motor	Q26	CPU	BRN-GRN	CPU CN 12-6	BLU/GRY	SMB J 3 - P 1/3	9v DC	---
14	Coil: Mirror Motor Relay	Q25	CPU	BRN-BLU	CPU CN 12-7	RED	PS CN 3-6, 7, 8	32v	---
15	Flashlamp: X1 Tommy	Q24	CPU	BRN-VIO	CPU CN 12-8	RED	PPB J 6-4, 5	32v R	Bulb #89
16	Coil: Not Used	---	---	---	---	---	---	---	---
17	Coil: Top Left Turbo Bumper	Q11	CPU	BLU-BRN	CPU CN 19-7	RED	PS CN 3-6	32v	23-800
18	Coil: Top Center Turbo Bumper	Q9	CPU	BLU-RED	CPU CN 19-4	RED	PS CN 3-6	32v	23-800
19	Coil: Top Right Turbo Bumper	Q8	CPU	BLU-ORG	CPU CN 19-3	RED	PS CN 3-6	32v	23-800
20	Coil: Left Slingshot	Q10	CPU	BLU-YEL	CPU CN 19-5	RED	PS CN 3-6	32v	23-800
21	Coil: Right Slingshot	Q12	CPU	BLU-GRN	CPU CN 19-6	RED	PS CN 3-6	32v	23-800
22	Coil: Not Used	---	---	---	CPU CN 19-9	---	PPB J 7-3	32v	23-800

Additional Coil(s) from Auxillary Board: Servo (GRN/WHT)/ GRY/ORG

NOTE 1: SEE THE PREVIOUS PAGE FOR LOCATIONS OF ABOVE ON THE PLAYFIELD AND BACKBOX.
 NOTE 2: SEE THE NEXT PAGE FOR THE COIL CHART SCHEMATIC.
 NOTE 3: FOR FLASHLAMPS, THE "X#" INDICATES FLASERS ON PLAYFIELD, THE REMAINDER ADDING UP TO "4 TOTAL" ON IN THE INSERT.

Flipper Solenoids

Coil Description	Flipper GND		Power Line FlipPC to Coil	Coil Type	Power Input To Flip. PCB
	CPU to Flip. Sw.	to Flip. PCB			
Left Flipper 090-5032-00	ORN-GRY CPU CN19-2	BLU-GRY CN1-19	GRY-YEL CN2-1,2	22-1000	BLK-WHT 50VDC
Right Flipper Lwr. 090-5032-00	ORN-VIO CPU CN19-1	BLU-VIO CN1-7	BLU-YEL CN2-4,5	22-1000	GRY/GRY-GRN 5VAC
Left Flipper Upr. 090-5032-00	ORN-VIO CPU CN19-1	GRY-VIO CN1-12	BLK-YEL CN2-1,2	25-1800	---

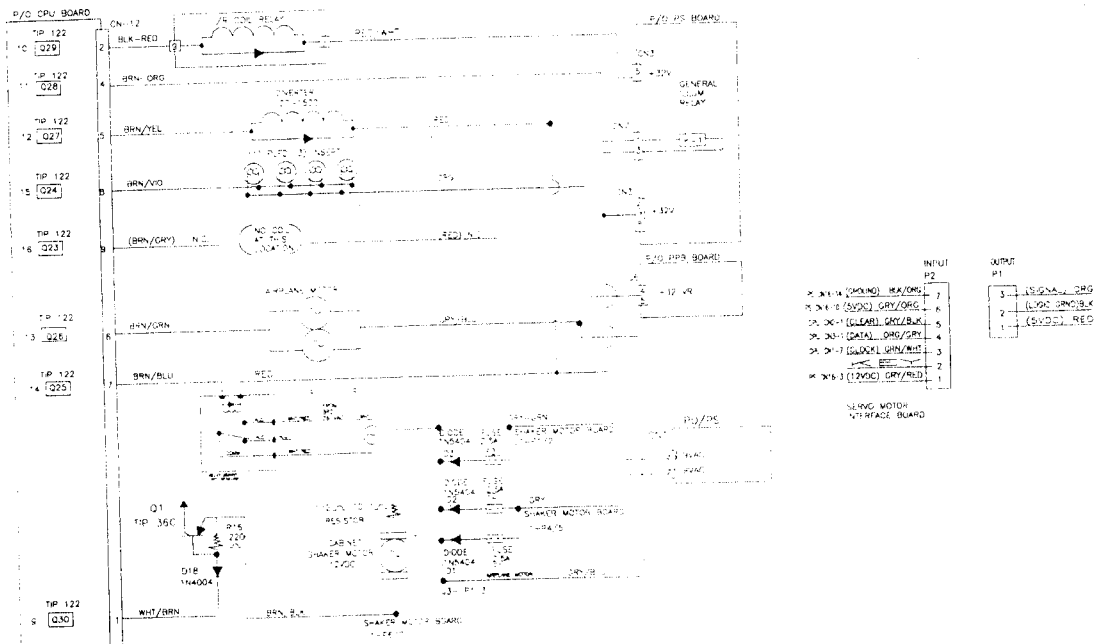
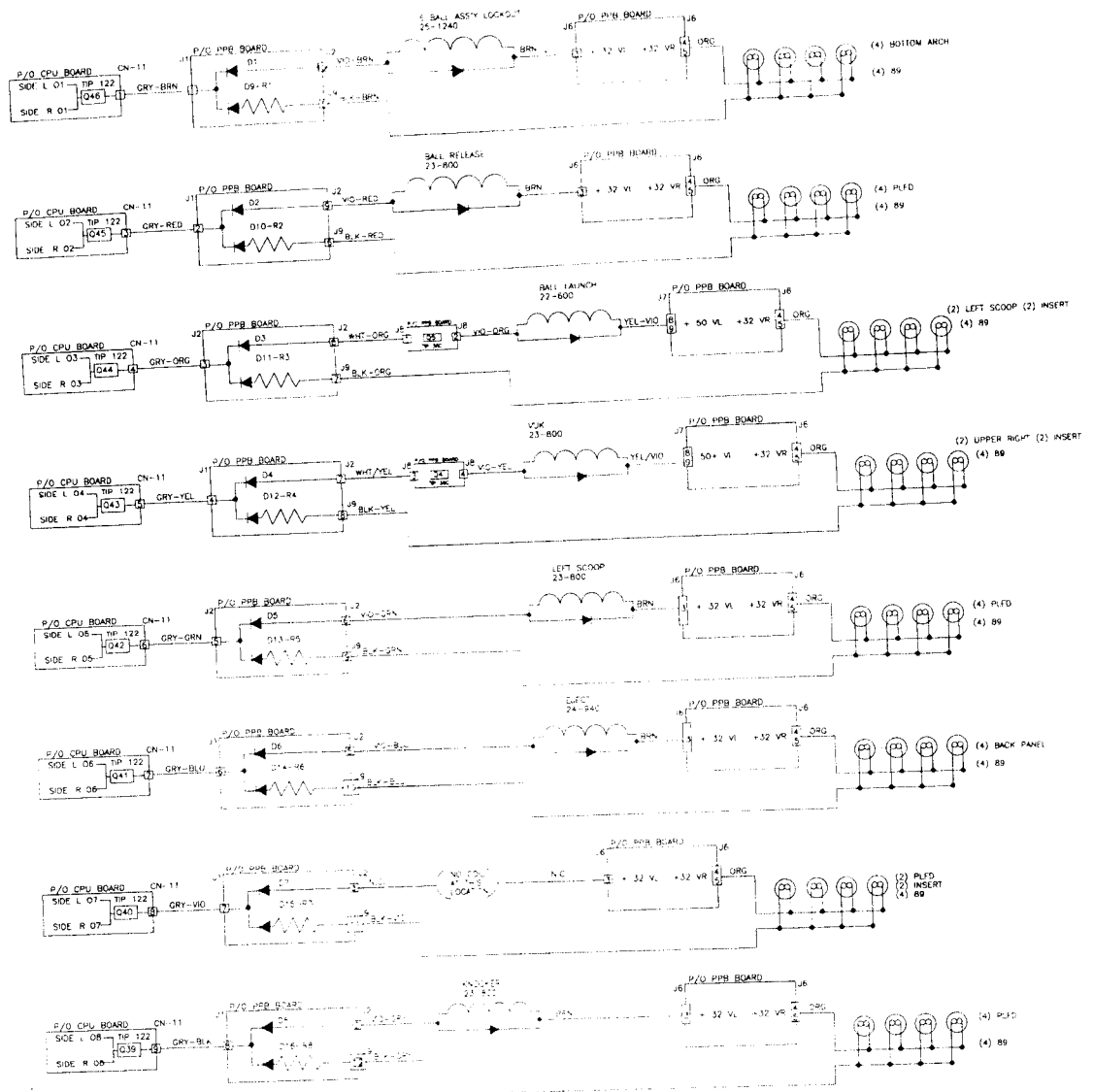

PARTS IDENTIFICATION Cabinet Parts Illustration

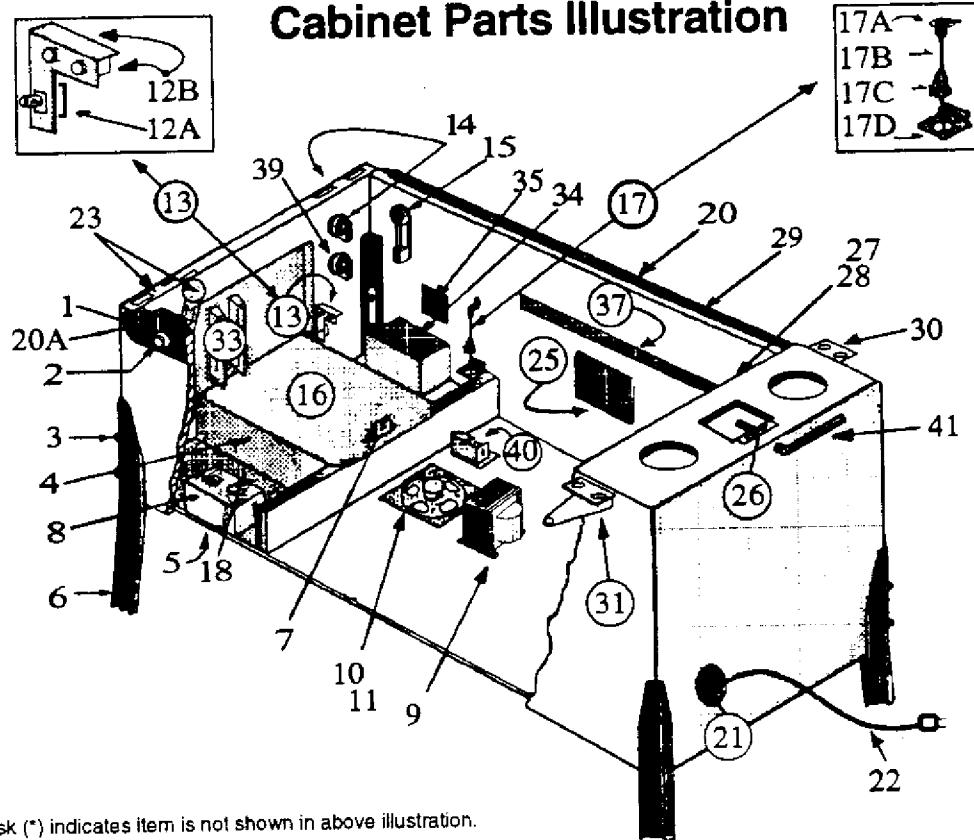

NOTE: An asterisk (*) indicates item is not shown in above illustration.

Item	Description	Part No.
1	Shooter Assembly Long Shaft	500-5744-00-04
2	Flipper Button	500-5026-32
3	Leg Bolt (Black) 3/8-16 x 2-3/8 Hex Hd.	231-5000-01
4	Cash Box Plastic Bottom	545-5090-00
5	Power Switch DPST Toggle	180-5001-00
6	Leg (Black) X4	535-5020-30
7	Cash Box Lock Bracket	535-5215-00
8	Service Outlet	515-5360-00
9	Transformer	010-5003-00
10	Speaker-Round - 8"	031-5005-00
11	Speaker Grill 7X7	545-5072-03
12A	Memory Protect Switch (Loc. in item 13)	180-5000-00
12B	Interlock & Momentary Diagnostics Switch Set (Located in item 13)	180-5012-00
13	Memory Protect Switch Bracket	535-6409-00
14	Start Button Switch Ass'y (Touch Me)	500-5728-01
15	Flipper Switch, Double, Left Top/Bottom	180-5122-00
15A	Flipper Switch, Upper, Right *	180-5048-01
16	Cash Box Cover (Validator)	535-5013-03
17	Plumb Bob Tilt Assembly	500-5023-00
17A	Hanger Bracket (tilt)	535-5221-00
17B	Hanger Wire (tilt) (Attach to *17A*)	535-5319-00
17C	Plumb Bob (tilt) (Attach to *17B*)	535-5029-00
17D	Contact Bracket (tilt)	535-5220-00
18	Volume Control Single 10K Pot	123-5000-02

Item	Description	Part No.
19	Playfield Glass (Tempered) * 21" x 43"	660-5001-00
20	Side Armor - Left	535-6831-01
20A	Side Armor - Right	535-6831-00
21	Recessed Cup for Line Cord	545-5122-00
22	Line Cord 10'	034-5000-00
23	Front Molding Lockdown Assy*	500-5020-00
24	Front Molding - Black *	500-5021-10
25	Solid State 3 - Flipper Board (SSFB)	520-5076-00
26	#1 Roto Lock Male	355-5006-01
27	Rear Plastic Ext. P/F Glass	545-5038-00
28	Mounting Fr. Rubber for Ext.	626-5004-00
29	Plastic Channel Left & Right	545-5017-00
30	Backbox Hinge Left	535-6172-00
31	Backbox Hinge Right	535-6172-01
32	Leg Leveler * 8-16x3" X4	500-5017-00
33	Coin Door (w/Validator) USA	500-5018-17
34	Shaker Motor (Not Used in this Game)	515-5893-00
35	Shaker Motor P.C. Board	520-5065-00
36	Slide & Pivot Support Brkt. Right*	535-5989-00
37	Slide & Pivot Spt. Brkt. Left	535-5990-00
38	Playfield Support Bar * (Stay Arm)	535-5019-00
39	Extra Ball Switch Ass'y (Orange)	500-5779-07
40	Knocker	500-5081-00
41	5/16" Hex Key Allen Wrench	777-0001-00
42	Backbox/Cabinet Matrix/Fuse Info *	820-6104-00
43	Safety Barrier (Cashbox Cover) *	545-5336-00

PLAYFIELD - MAJOR ASSEMBLIES

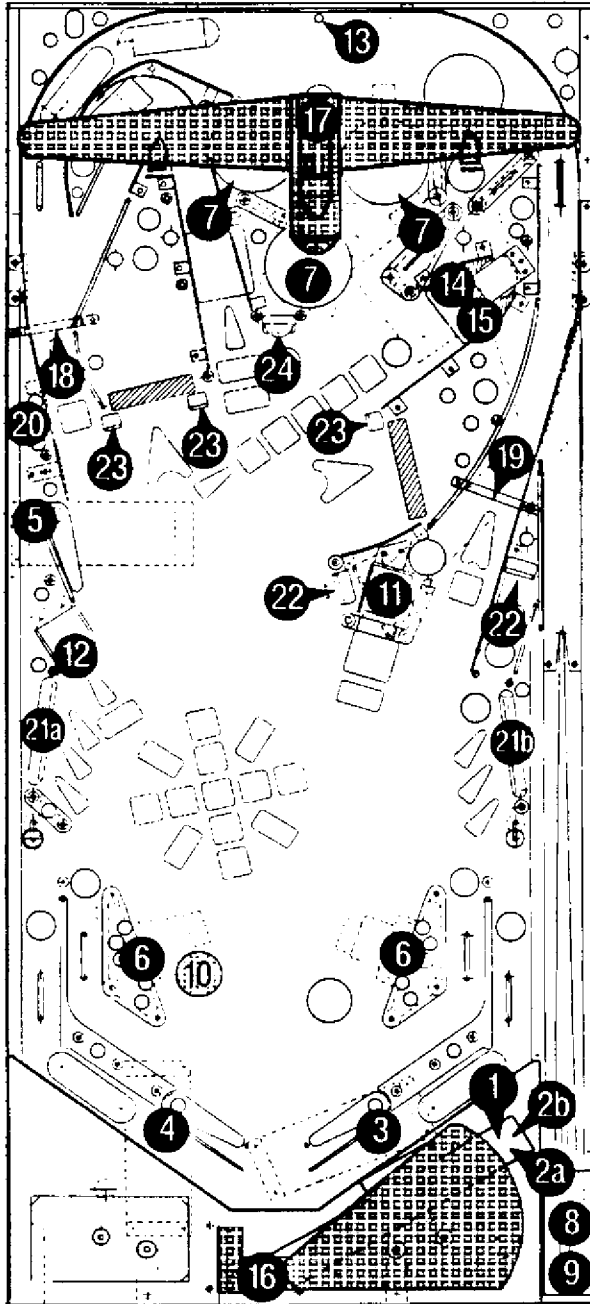

Item	Description	Part No.
1	6-Ball Switch Assembly (Under Playfield)	500-5683-01
2a	Lock Ball Assembly (Under Arch, Above Playfield)	500-5684-01
2b	Deflector for 6-Ball Ass'y (Under Arch)	535-6606-01
3	Flipper Assembly Lower Right	500-5693-01
4	Flipper Assembly Lower Left	500-5693-02
5	Flipper Assembly Upper Left	500-5795-02
6	Slingshot Assembly (X2)	500-5226-00
7	Turbo Bumper (X3)	500-5227-00
8	Shooter/Kicker Assembly (Auto Ball Launch)	500-5769-00
9	Shooter Assembly Long Shaft	500-5744-XX
10	Knocker Ass'y (In Cabinet Bottom, See Item 40, Pg. 37)	500-5081-00
11	Super VUK Assembly (Right)	500-5116-00
12	Super VUK Ass'mly (Scoop Left)	500-5716-00
13	Ball Deflector	500-5788-00
14	Motor, Cam & Switch Ass'y (Mirror)	500-5742-01
15	Target Back Plate Ass'y (Mirror)	515-5905-XX
16	Blinder Assembly (Under Arch, Above Playfield)	500-5775-00
17	Airplane Assembly	515-5949-00
18	Spinner Assembly Left	500-5785-00
19	Spinner Assembly Right	500-5784-00
20	Spot Light & Bracket Assembly	500-5792-00
21a	3-Bank Target Round Ass'y Left	500-5781-00
21b	3-Bank Target Round Ass'y Right	500-5781-01
22	1-Single Round S/U Ass'y (X2)	500-5783-00
23	Single Narrow S/U Ass'y (X3)	500-5780-00
24	Single Chrome Pinball S/U Ass'y	500-5762-00
<p>Note 1: Switch part numbers are located on Page 33</p> <p>Note 2: Ramps & Wire Ramps not shown on drawing.</p>		

PLAYFIELD - MAJOR RAMP ASSEMBLIES & RELATED PARTS

Item	Description	Part No.
A	Steel Ramp Assembly Left	500-5789-00
A1	Steel Ramp Left	515-5971-00
A2	Butyrate	830-5457-20
A3	#6x 3/8 HEX WSMS 4PLS	234-5000-00
A4	Ramp Flap (Left)	535-6856-00
A5	Rollunder Gate Ass'y Left	515-5974-00
A5a	Gate Shield	535-6875-01
A5b	Wire Form	535-6861-01
A5c	Butyrate	830-5457-22
A5d	Rivet (2)	249-5001-00
A5e	Switch	180-5090-00
A5f	2-56 PHMS Sems (2)	237-5872-00
A5g	Switch Protect Plate	535-6539-00
A5h	Diode	112-5001-00
A5i	Cable	036-5334-00
A5j	For Sockets & Bulbs See Page 42.	
A6	1/8X1/8 Rivet 2 PLS	249-5008-00
A7	1/8X3/16 Rivet 2 PLS	249-5001-00
A8	Switch Assembly	180-5093-00
A8a	Bracket	535-6863-00
A8b	Protector Plate	535-6539-00
A8c	2-56X3 Screw (2)	237-5872-00
A8d	Diode IN4001-00	112-5001-00
A8e	Cable	036-5334-01
A9	Ramp Mounting Bracket	535-6899-00
B	Steel Ramp Assembly Right	500-5790-00
B1	Steel Ramp Right	515-5970-00
B2	Ramp Flap Right	535-6855-00
B3	Rollunder Gate Ass'y Right	515-5973-00
B3a	Gate Shield	535-6875-00
B3b	Wire Form	535-6861-00
B3c	Butyrate	830-5457-21
B3d	Rivet (2)	249-5001-00
B3e	Switch	180-5090-00
B3f	2-56 PHMS Sems (2)	237-5872-00
B3g	Switch Protect Plate	535-6539-00
B3h	Diode	112-5001-00
B3i	Cable	036-5334-00
B3j	For Sockets & Bulbs See Page 42.	
B4	#6X 3/8 HEX WSMS 4 PLS	234-5000-00
B5	1/8-X1/8 Rivet 2 PLS	249-5008-00
B6	Butyrate	830-5457-21-A
B7	1/8X3/16 Rivet 2 PLS	249-5001-00
B8	Switch Assembly	180-5093-00
B8a	Bracket	535-6863-00
B8b	Protector Plate	535-6539-00
B8c	2-56X3 Screw (2)	237-5872-00
B8d	Diode IN4001-00	112-5001-00
B8e	Cable	036-5334-01
B9	Ramp Mounting Bracket	535-6900-00
C	Wire Ramp Long. Left	535-6846-00
D	Wire Ramp Long. Right	535-6845-00
E	Wire Ramp Short (VUK)	535-6854-00
F	Under Ramp Ass'y (Trough)	500-5787-00
F1	Under Trough Ramp	515-5969-00
F2	1/8 X3/16 Rivet (4)	249-5001-00
F3	Micro Switch Assembly (2)	500-5711-00
F4	1-Way Wire Gate	535-6892-00

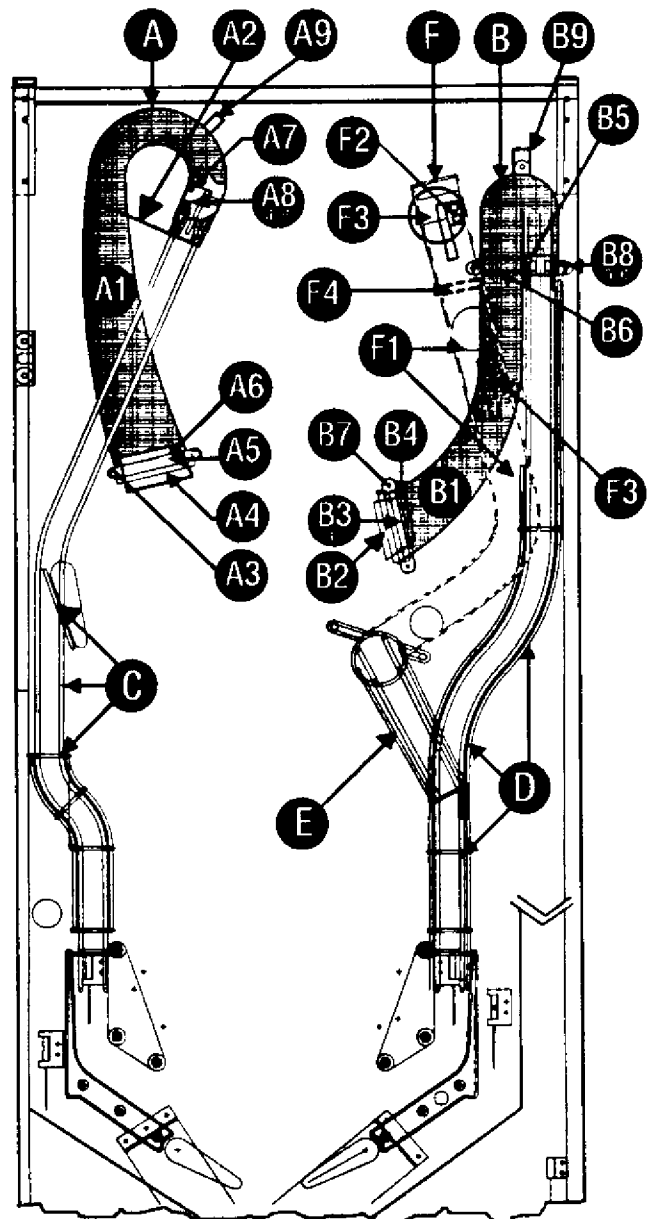

BACKBOX - PARTS

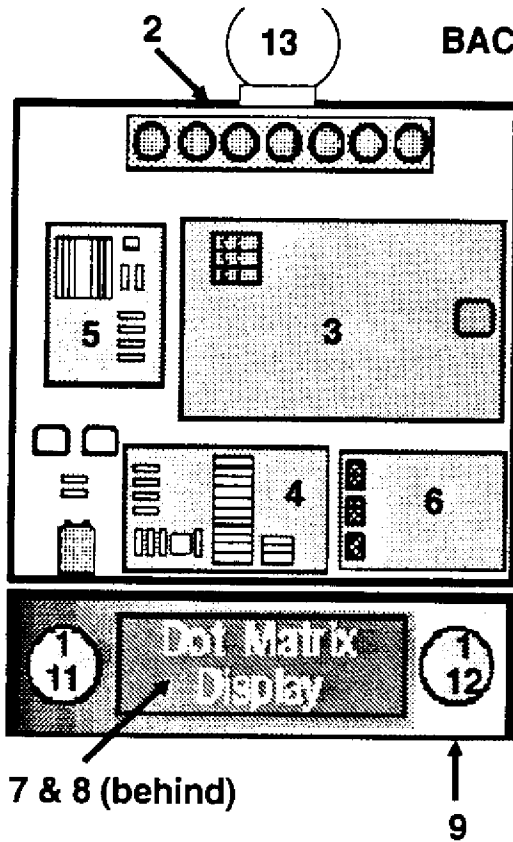

Item	Description	Part No.
1	Speakers	031-5004-00
2	Back Box Lock	355-5008-00
3	CPU (See Note 1)	520-5003-04
4	PPB Board	520-5021-05
5	Power Supply	520-5047-02
6	Sound Board (See Note 1)	520-5077-00
7	Dot Matrix Display Bd. (See Note 2)	520-5052-00
8	Display Controller Bd. (See Note 1)	520-5055-01
9	Speaker Housing	545-5180-02
10	Tommy Backglass Artwork (Film) *	830-5228-00
11	Speaker Grill Left (Tommy)	830-5625-00
12	Speaker Grill Right (Tommy)	830-5625-00
13	Backbox Header: Silver Ball	545-5221-00
14	Static Shield *	535-6437-00
15	Backglass Clear *	660-5008-00
16	26" Plastic Extrusion *	545-5018-04
17	21-3/8" Plastic Extr. (2) *	545-5018-07
18	Glass Channel 26-1/16 *	545-5021-01

Asterisk (*) Indicates not shown in diagram.

Note 1: When ordering PC Boards with ROMS, please specify the Game Name.

Note 2: Indicate Manufacturer

PLAYFIELD - RUBBER PARTS

Item	Description	Part No.
A	3/16" I.D. Rubber Ring (4)	545-5348-01
B	5/16" I.D. Rubber Ring (2)	545-5348-02
C	3/8" O.D. Rubber Ring (3)	545-5348-19
D	1" I.D. Rubber Ring (3)	545-5348-05
E	1-1/4" I.D. Rubber Ring (Not Used)	545-5348-06
F	1-1/2" I.D. Rubber Ring (1)	545-5348-07
G	1-3/4" I.D. Rubber Ring (1)	545-5348-21
H	2-3/4" I.D. Rubber Ring (2)	545-5348-20
I	Flipper Rubber Rings (3)	545-5277-00
J	Rubber/Sponge Sleeve Short (14)	545-5151-00
K	Rubber Sleeve Tall, Thin (4)	545-5308-00
L	Bumper Post Rubber (2)	545-5009-00

Items Below are not shown in diagram.

Posts	Part No.
Spacer (Hex. Tapped 6-32 1/2") X4	254-5008-03
Spacer (Hex. Tapped 6-32 1") X2	254-5008-06
Spacer (Hex. Tapped 6-32 1-1/2") X9	254-5008-09
Spacer (Hex. Tapped 6-32 2") X1	254-5008-07
Spacer (Plastic, Gray 1") X15	254-5000-04
Spacer (Plastic, Gray 3/4") X2	254-5000-07
Standoffs (Metal, 1") Tapped Hole X3	530-5007-00
Standoffs (Metal, 1") Untapped Hole X5	530-5127-00
Standoffs (Plastic, Gray) X25	550-5059-00
Minipost Wood (Metal) X3	530-5004-00

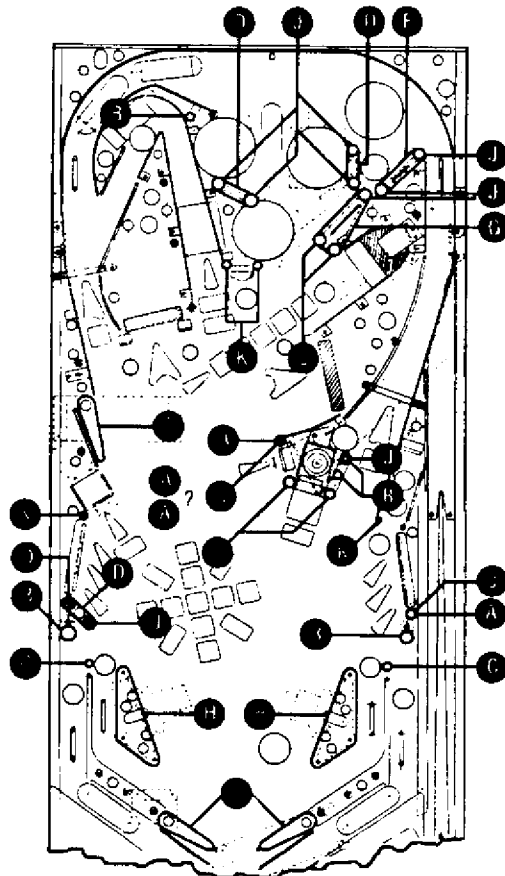

PLAYFIELD TOP PARTS

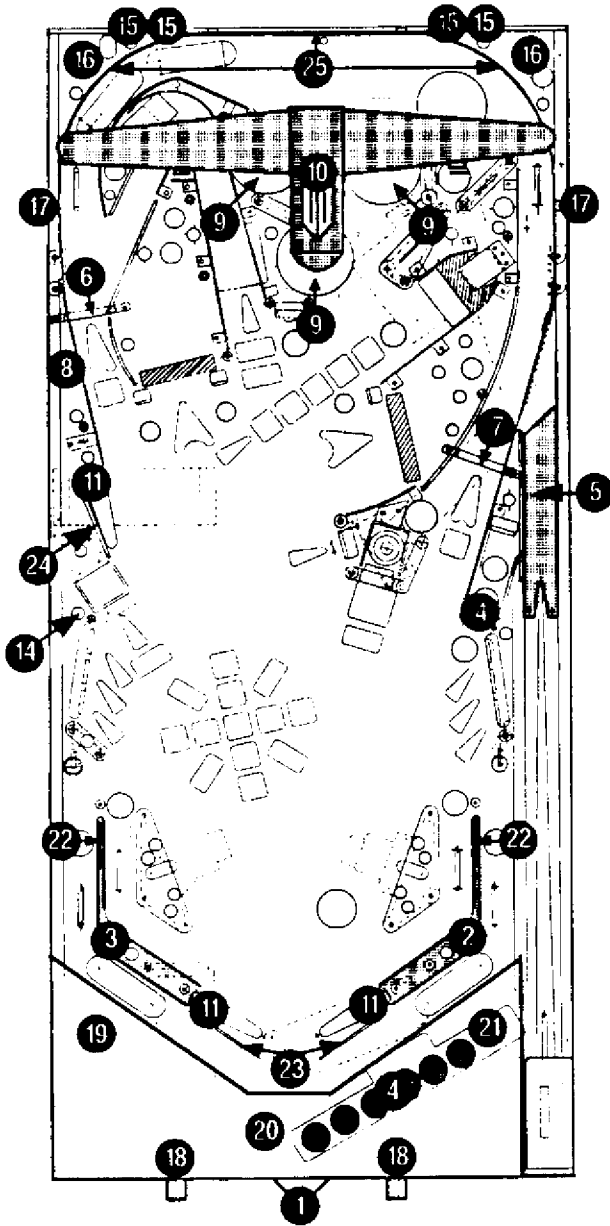

Note:
 -- Steel & Wire Ramps are not shown.
 -- To order replacement Butyrate, use Part # 830-5457-XX; the last 2-digits are printed on the individual pieces.

Item	Description	Part No.
1	Bottom Arch Assembly (Metal)	500-5776-00
2	Ball Guide - Right Return	550-5037-01
3	Ball Guide - Left Return	550-5037-01
4	1-1/16" Steel Balls, 1-Captive, 6-Play	260-5000-00
5	Shooter Lane Launch Ramp	535-6840-00
6	Spinner Assembly Left	500-5785-00
7	Spinner Assembly Right	500-5784-00
8	Spotlite & Bracket Assembly	500-5792-00
9	Pop Bumper Cap (Red) X3	550-5057-02
10	Airplane Bomber (Ass'y Plastic Cover)	545-5433-00
11	Flippers & Shaft Ass'y (White) X3	515-5133-01
12	Lite Cover - (Orange) X2 LT/RT Ramps	545-5014-07
13	Lite Cover - (Yellow) X2 LT/RT Ramps	545-5014-06
14	Lite Cover (Red) Hat (On Butyrate)	550-5032-02
15	Minimars (Clear) X4	550-5031-01
16	Minimars (Red) X2	550-5055-02
17	Pivot Pin Bracket Ass'y X2, with Pivot Bracket Screws X4, and T-Nut X4	500-5329-00 237-5907-00 240-5101-00
18	Playfield Hanging Bracket X2	535-5216-00
19	Decal - Tommy (Arch Center)	820-5088-01
20	Decal - (Arch Left)	820-5088-02
21	Decal - (Arch Right)	820-5088-03
22	Wire Form on Ball Guide X2	535-5642-00
23	Snubbers (Bottom Flippers)	535-5373-01
24	Wire Form 3" (Upper Flipper Left)	535-5356-04
25	Flat Rail - Orbit (Outside, Long)	515-5963-00

Items Below are not shown in diagram.	
More Decals	Part No.
Mylar, Individual Pieces	820-5835-00
Pop Bumper Decal - See Me	820-5088-05
Pop Bumper Decal - Touch Me	820-5088-06
Pop Bumper Decal - Heal Me	820-5088-07
Left Eye Decal (On Blinder)	820-5088-08
Right Eye Decal (On Blinder)	820-5088-09
More Flat Rails	Part No.
Flat Rail (To Eject Hole Lane, Left)	535-6839-00
Flat Rail (To Eject Hole Lane, Right)	535-5964-00
Flat Rail (Orbit Left, Inside Right)	535-5965-00
Flat Rail (Orbit Right, Inside Left)	535-6852-00
Flat Rail (Outlane Left, Under Arch)	535-6787-00
Flat Rail (Outlane Right, Under Arch)	535-6788-00
Flat Rail (Left of Mirror Target)	535-6770-00
Flat Rail (Right of Mirror Target)	535-6769-00
Flat Rail (Back of Mirror Target)	535-6841-00

Items Below are not shown in diagram.	
More Wire Forms	Part No.
Wire Form - On Ball Guide Return X2	535-5642-00
Wire Form 2" - Top of Right Bumper	535-5300-10
Wire Form 2.5" - Left of Eject Hole	535-5356-09
Wire Form 4.62" - Right of Eject Hole	535-5356-06
Wire Form 2" - Left & Top of Mirror	535-5300-10
Wire Form 1" - Right of Skill Shot	535-5300-05
Wire Form - Inside Right of Left Spinner	535-6851-00
Wire Form - Inside Left of Right Spinner	535-5356-07

Switch Part Numbers are listed on Page 33.
 Cabinet Parts are listed on Page 39.
 Major Assemblies Parts are listed on Page 40.
 Steel & Wire Ramp Parts are listed on Page 41.
 Posts & Rubber Parts are listed on Page 42.
 Sockets & Lamps are listed on Pages 44 and 45.

SOCKETS

Item	Socket Description	Part No.	Qty.
1	2-Lug Staple Down	077-5000-00	65
2	3-Lug Staple Down	077-5001-00	10
3	2-Lug Stand-Up Long	077-5005-00	3
4	3-Lug Laydown	077-5006-00	3
5	1-Lug Stand-Up Long Shell	077-5012-00	1
6	3-Lug Stand-Up Long	077-5009-00	12
7	555 Wedge	077-5007-00	36
8	906 Wedge	077-5016-00	2
9	Laydown Wedge Base Black	077-5026-00	1
10	Laydown Wedge Base L/R Black (Used with Reflectors)	077-5026-01	3
11	Wedge Offset Bracket (on Ramps)	077-5029-00	4
12	Laydown Standard	077-5700-00	1
13	Stand-Up, Short	077-5101-00	15
14	Stand-Up, Long	077-5102-00	15
15	Straight Leg	077-5107-00	3

ILLUSTRATIONS BELOW ARE NOT SHOWN AS ACTUAL SIZE.

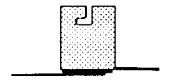
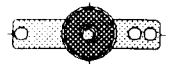

SOCKET
1

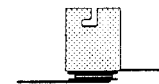
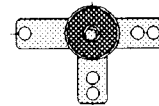

SOCKET
2

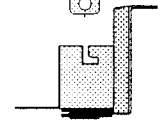
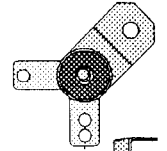

SOCKET
3

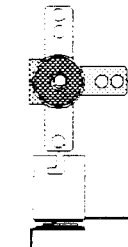

SOCKET
4

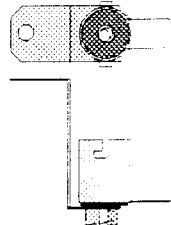

SOCKET
5

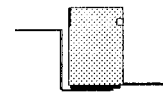
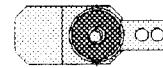

SOCKET
6



SOCKET
7



SOCKET
8

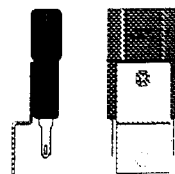

SOCKET
9

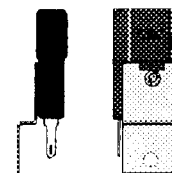

SOCKET
10

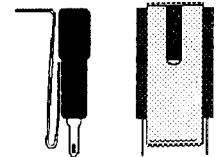

SOCKET
11

Note the notch in bracket

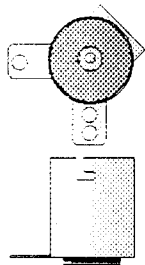

SOCKET
12

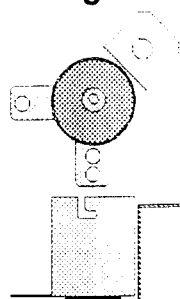

SOCKET
13

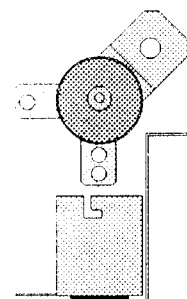

SOCKET
14

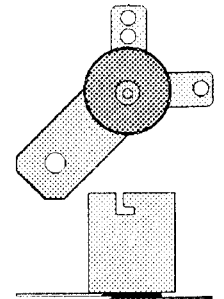

SOCKET
15

LAMP BOARD LAYOUTS & LAMP BULB PART NUMBERS

Item	Description	Part No.
A	Lamp Board	520-5073-05
B	Lamp Board	520-5073-01
C	Lamp Board	520-5073-06
D	Lamp Board	520-5073-04
E	Lamp Board	520-5073-08
F	Lamp Board	520-5073-03
G	Lamp Board	520-5073-07
H	Lamp Board	520-5073-02

Item	Bulb Description/ Part No.	Qty.
1	#44 Bulb - 165-5000-44	92
2	#89 Bulb - 165-5000-89	34
3	#555 Wedge Base - 165-5002-00	47
4	#455 Bulb - 165-5003-00 Note: Located in Insert (Backbox)	2
5	#906 Wedge Base - 165-5004-00	2

ILLUSTRATIONS BELOW ARE SHOWN AS ACTUAL SIZE.

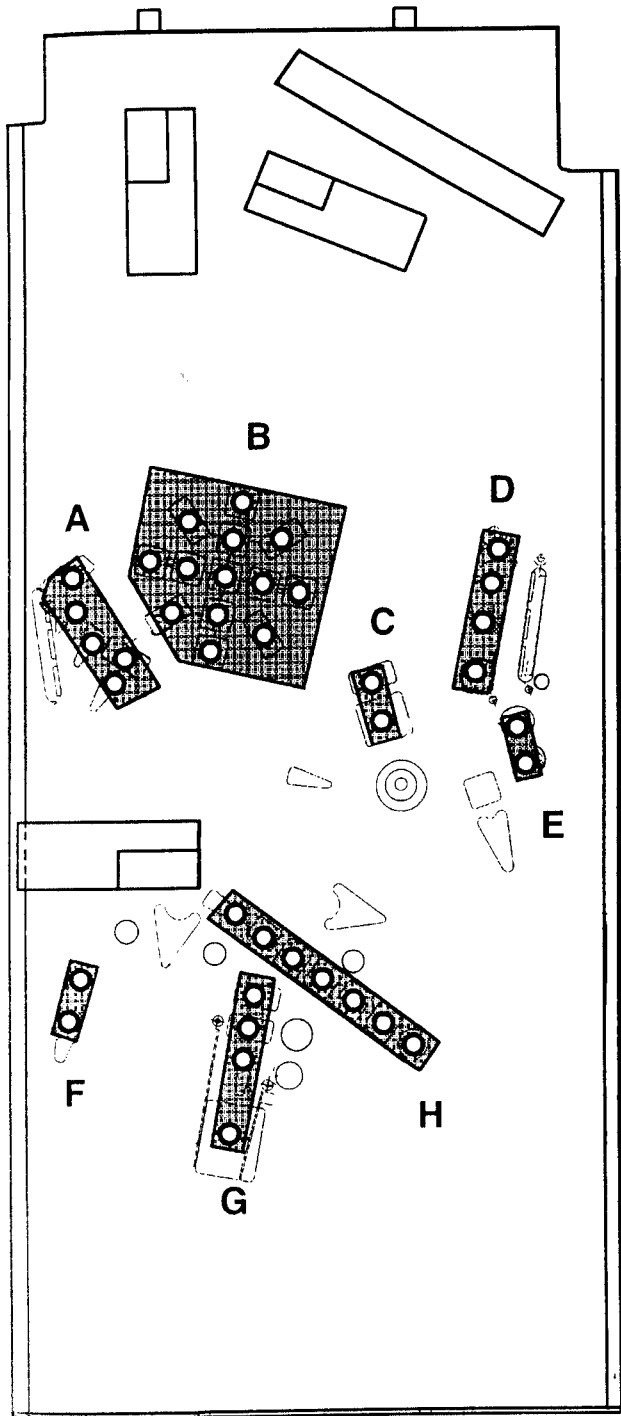

UNDER PLAYFIELD: BOTTOM VIEW

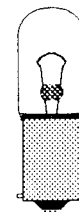

LAMP
1

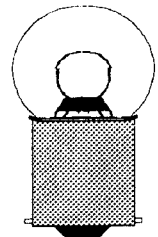

LAMP
2

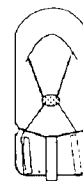

LAMP
3

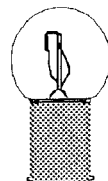

LAMP
4

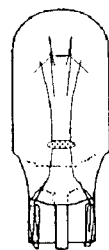

LAMP
5

NOTES

UNIQUE PARTS

Lock Ball Assembly 500-5684-01

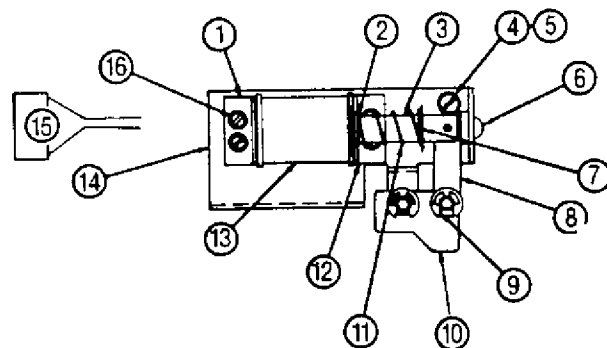

Deflector 535-6606-01

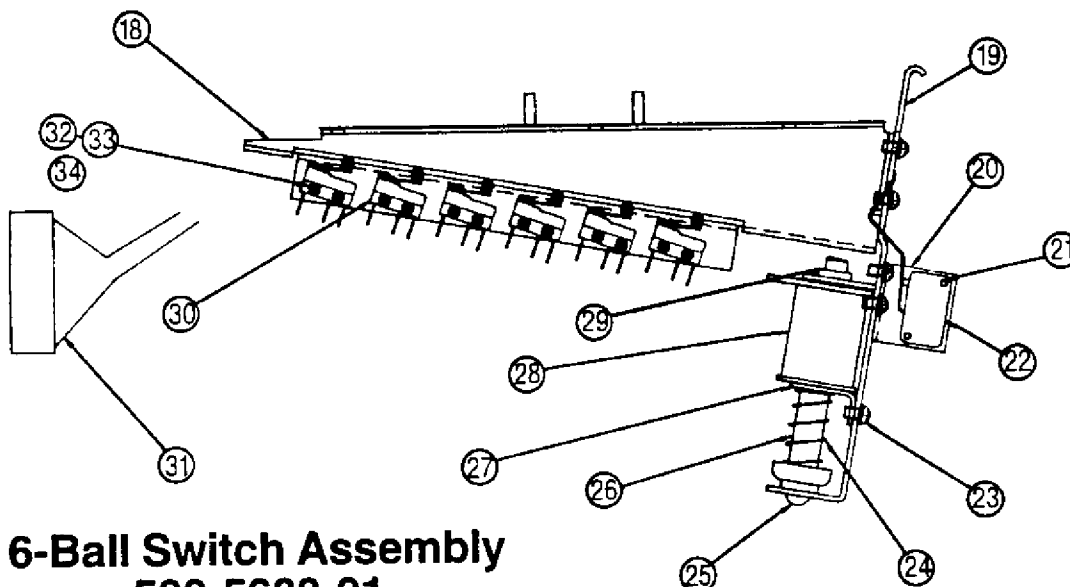
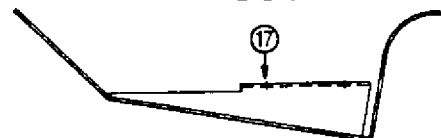

6-Ball Switch Assembly 500-5683-01

Item	Description	Part No.	Item	Description	Part No.
1	Core Stop Assembly	515-5088-00	18	Outhole Mounting Bracket	535-6621-01
2	Coil Sleeve	545-5411-00	19	Coil Mounting Bracket	535-6622-01
3	Plunger *7/16 X 2-1/4 LG	530-5250-01	20	Switch Mounting Bracket	535-6623-00
4	Spacer	545-5400-00	21	#4-40 PPH X .62 LG (2)	237-5806-00
5	#8-32 PPH X 1" LG	232-1104-16	22	Switch, Miniature	180-5119-00
6	Rubber Bumper	545-5105-00	23	#8-32 PPH w/SEM X .25 LG (8)	232-5300-00
7	E-Ring, .44 Shaft	270-5005-00	24	Spring	266-5020-00
8	Link, Lock Ball	535-6649-00	25	Rubber Bumper	545-5105-00
9	E-Ring, .25 Shaft (2)	250-0008-00	26	Plunger Assembly	515-5000-02
10	Lock Ball Cam Assembly	515-5815-01	27	Coil Retaining Bracket	535-5203-01
11	Spring	266-5000-00	28	Coil, 23-800	090-5001-00
12	Coil Retaining Bracket	535-6658-00	29	Coil Sleeve	545-5076-00
13	Coil, 25-1240	090-5034-00	30	Switch, Subminiature (6)	180-5119-00
14	Lock Ball Bracket Assembly	515-5817-01	31	Wire Harness	036-5301-00
15	Wire Harness	036-5301-01	32	#2-56 PPH X .5 LG (12)	237-5806-00
16	#6-32 HWH TC X .38 LG (4)	237-5898-00	33	#2 Split LW (12)	244-5001-00
17	Deflector	535-6606-01	34	Switch Protector (6)	535-6539-00

Flipper Assembly Lower 500-5693-01 (Right), - 02 (Left)

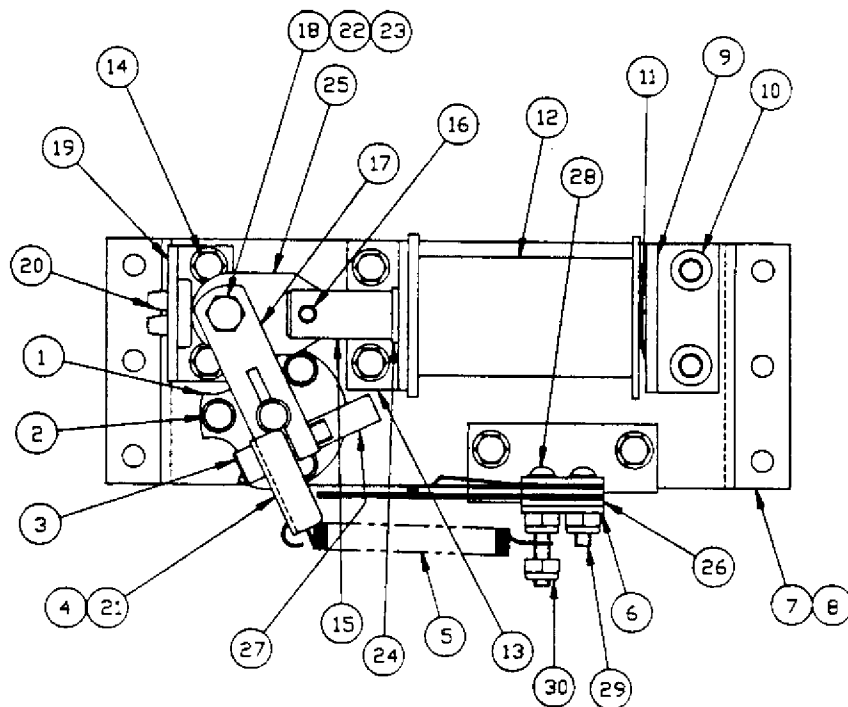

Item	Part No.	Description	Qty.
1	545-5070-00	Flipper Bushing	1
2	234-5000-00	#6-32 x .38 LG. HWH TF	3
3	237-5864-00	#10-32 SOC HD x .75 LG.	1
4	535-6663-02	Spring Bracket (Left)	1
5	265-5029-02	Flipper Return Spring	1
6	535-6664-00	Switch Mounting Bracket	1
7	515-5077-02	Flipper Base (Left)	1
8	515-5077-01	Flipper Base (Right)	1
9	515-5346-00	Coil Stop Bracket	1
10	237-5861-00	1/4-20 SOC HD x .38 LG.	2
11	269-5002-00	Spring Washer	1
12	090-5020-30	Coil 23-900	1
13	535-6453-00	Front Bracket	1
14	234-5100-00	#8-32 x .38 LG. HWH TF	6
15	515-5822-00	Plunger and Link Assembly	1
16	251-5000-00	Roll Pin	1
17	530-5070-00	Pawl	1
18	231-5019-00	#10-32 x .75 LG. Shoulder Bolt	1
19	535-5279-01	Plunger Stop Bracket	1
20	545-5445-00	Nylon Stop	1
21	535-6663-01	Spring Bracket (Right)	1
22	530-5139-00	Bushing	1
23	240-5206-00	#10-32 Elastic Stop Nut	1
24	545-5388-00	Coil Sleeve	1
25	545-5401-00	Flipper Link	1
26	180-5124-00	End of Stroke Switch	1
27	545-5084-00	Plastic Cap	1
28	237-5506-00	#6-32 x 1" LG. PPH	1
29	237-5899-00	#6-32 x .63 LG. PPH	1
30	240-5005-00	#6-32 Elastic Stop Nut	3

Flipper Assembly Upper 500-5756-02 (Left)

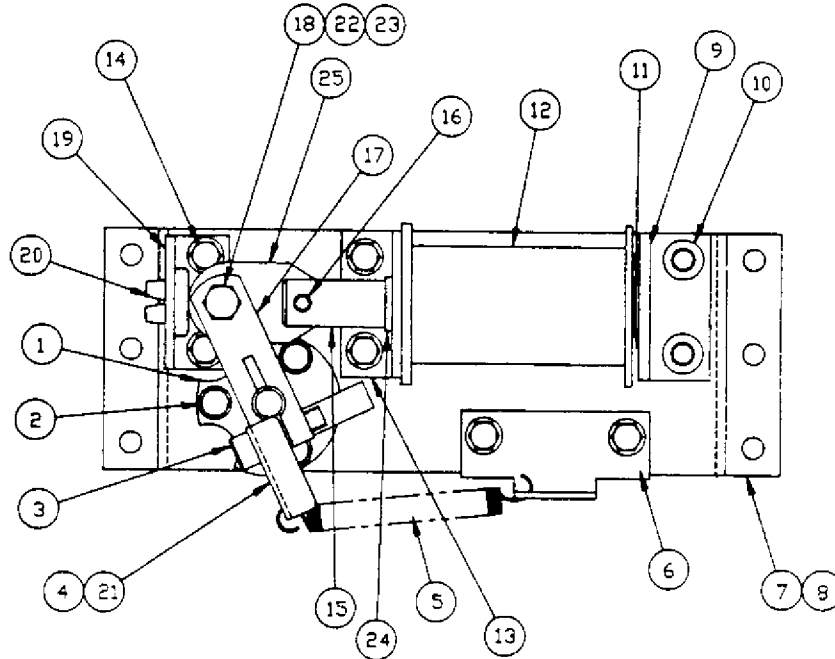

Item	Part No.	Description	Qty.
1	545-5070-00	Flipper Bushing	1
2	234-5000-00	#6-32 x .38 LG. HWH TF	3
3	237-5864-00	#10-32 SOC HD x .75 LG.	1
4	535-6663-02	Spring Bracket (Left)	1
5	265-5029-02	Flipper Return Spring	1
6	535-6664-00	Switch Mounting Bracket	1
7	515-5077-02	Flipper Base (Left)	1
8	515-5077-01	Flipper Base (Right)	1
9	515-5346-00	Coil Stop Bracket	1
10	237-5861-00	1/4-20 SOC HD x .38 LG.	2
11	269-5002-00	Spring Washer	1
12	090-5020-30	Coil 23-900	1
13	535-6453-00	Front Bracket	1
14	234-5100-00	#8-32 x .38 LG. HWH TF	6
15	515-5822-00	Plunger and Link Assembly	1
16	251-5000-00	Roll Pin	1
17	530-5070-00	Pawl	1
18	231-5019-00	#10-32 x .75 LG. Shoulder Bolt	1
19	535-5279-01	Plunger Stop Bracket	1
20	545-5445-00	Nylon Stop	1
21	535-6663-01	Spring Bracket (Right)	1
22	530-5139-00	Bushing	1
23	240-5206-00	#10-32 Elastic Stop Nut	1
24	545-5388-00	Coil Sleeve	1
25	545-5401-00	Flipper Link	1

Slingshot Assembly 500-5226-00

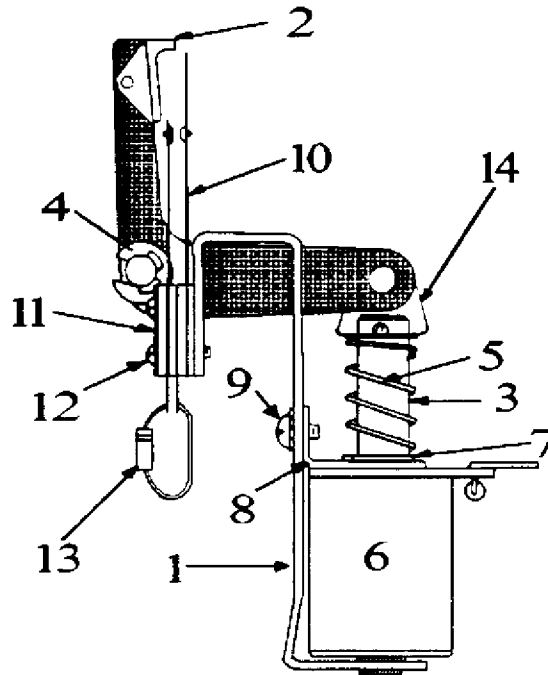

Item	Description	Part No.
1	Slingshot Bracket	515-5339-00
2	S. S. Arm & Tip Assembly	515-5340-00
3	Plunger & Link Assembly	515-5338-00
4	1/4 Retaining Ring (2)	270-5002-00
5	Spring	266-5020-00
6	23-800 Coil	090-5001-00
7	Coil Sleeve	260-0004-00
8	Coil Retainer	535-5203-03
9	#8-32 X 1/4" Screw (2)	232-5300-00
10	Slingshot Switch (2)	180-5054-00
11	Tension Plate (2)	535-5846-00
12	#4-40 X 1/2" Screw (4)	237-5837-00
13	Diode 1N4004 (2)	112-5004-00
14	Link	545-5062-00

Turbo Bumper 500-5227-00

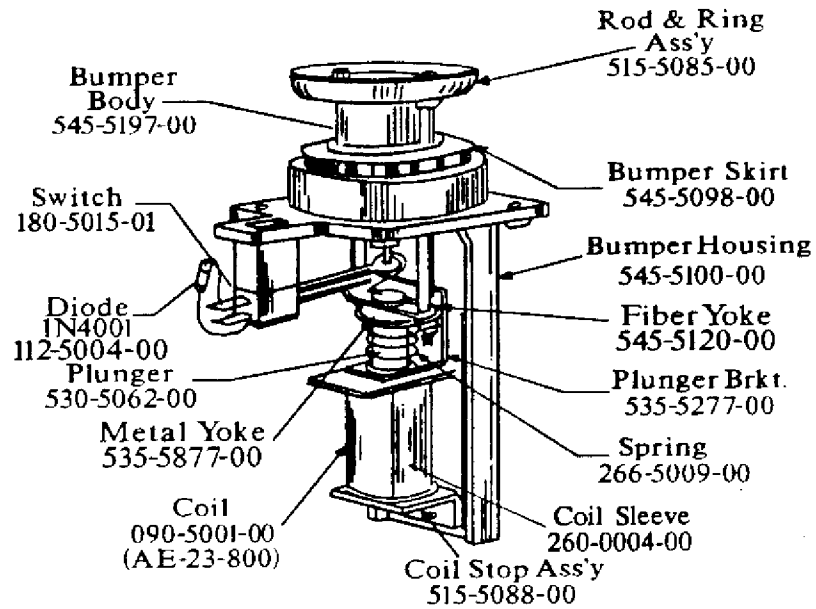

Knocker Assembly 500-5081-00

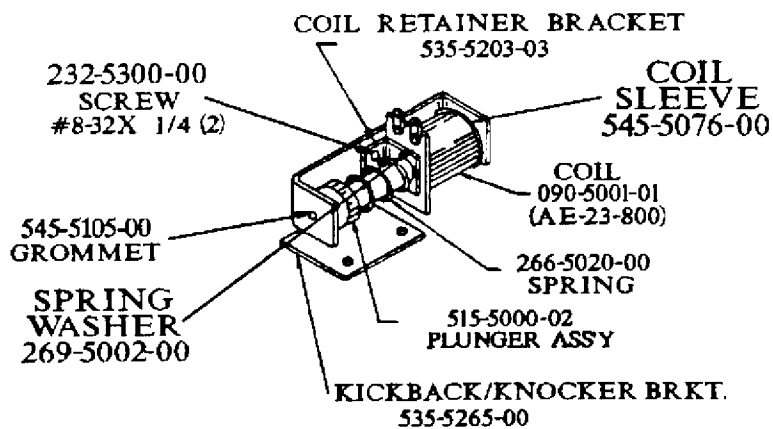

Shooter/Kicker (Auto Ball Launch) Ass'y 500-5769-00 & Shooter Assembly Long Shaft 500-5744-XX

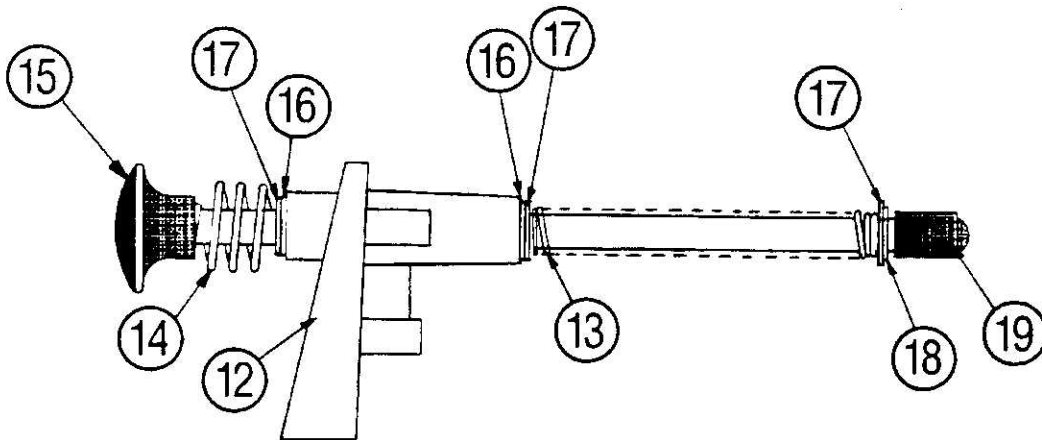
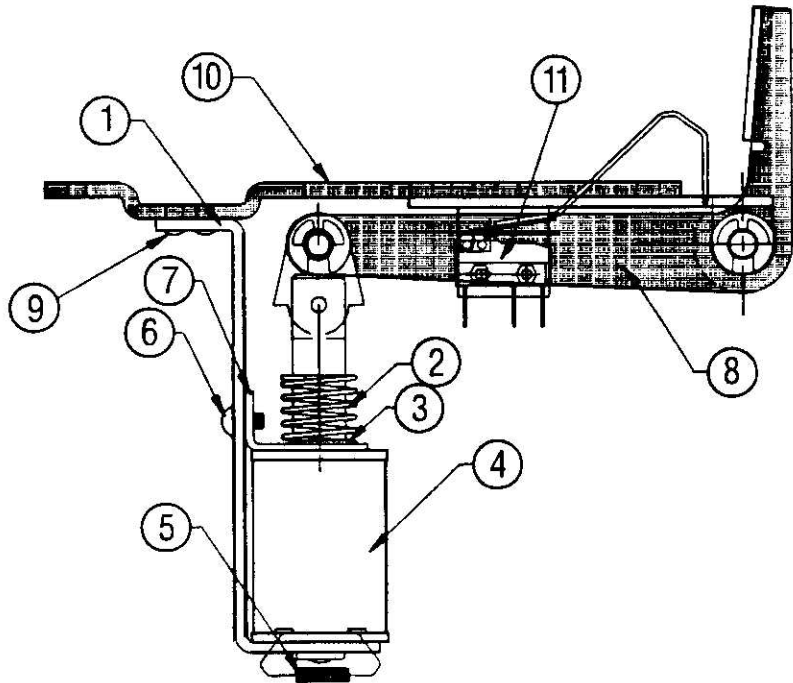

Item	Description	Part No.
1	Bracket/Stop Assembly	515-5351-00
2	Plunger Spring	266-5022-00
3	Coil Sleeve	545-5031-00
4	Coil 22-600	090-5023-00
5	Diode 1N4004	112-5003-00
6	8-3X1/4 Sems (2)	232-5300-00
7	Coil Bracket	535-5633-00
8	Kick/Plunge Assembly	515-5633-00
9	6-32X3/8 PHMS (3)	232-5301-00
10	Bracket	535-6898-00

Item	Description	Part No.
11	Switch	180-5100-01
12	Housing (Shooter Ass'y)	535-5067-00
13	Spring Large	266-5001-04
14	Spring Small	266-5010-00
15	Rod Assembly	515-5924-01
16	Bushing (2)	280-5010-00
17	Washer (3)	242-5014-00
18	Retaining Ring	270-5012-00
19	Plunger Tip	545-5276-00

Shooter/Kicker (Auto Ball Launch) Ass'y 500-5769-00

Note: Early production games use this assembly. Proper identification can be made by noting the coil mounting position (sits vertical).

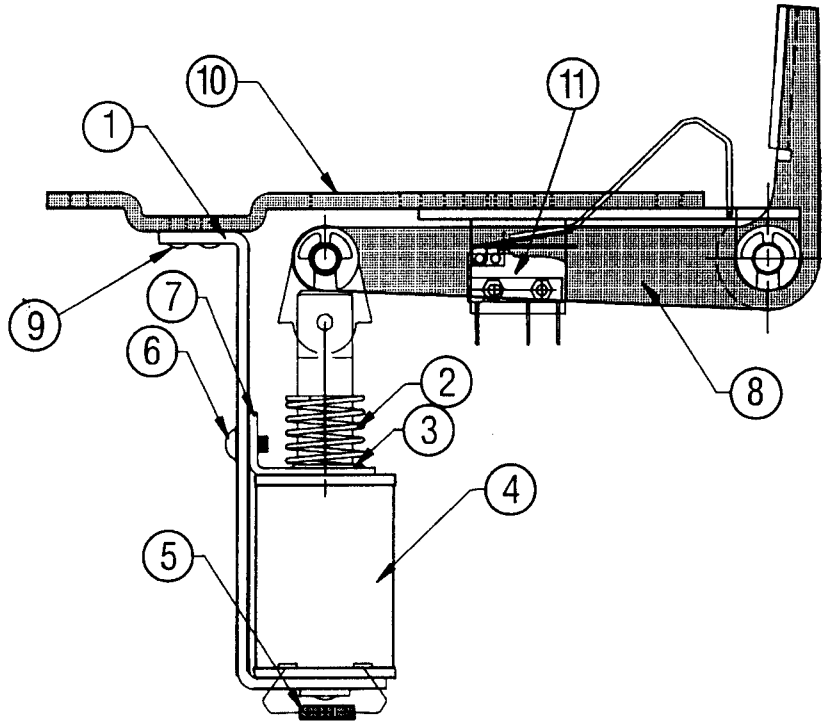

Item	Description	Part No.
1	Bracket/Stop Assembly	515-5351-00
2	Plunger Spring	266-5022-00
3	Coil Sleeve	545-5031-00
4	Coil 22-600	090-5023-00
5	Diode 1N4004	112-5003-00
6	8-3X1/4 Sems (2)	232-5300-00
7	Coil Bracket	535-5633-00
8	Kick/Plunge Assembly	515-5633-00
9	6-32X3/8 PHMS (3)	232-5301-00
10	Bracket	535-6898-00
11	Switch	180-5100-01

Super VUK Ass'y 500-5116-06

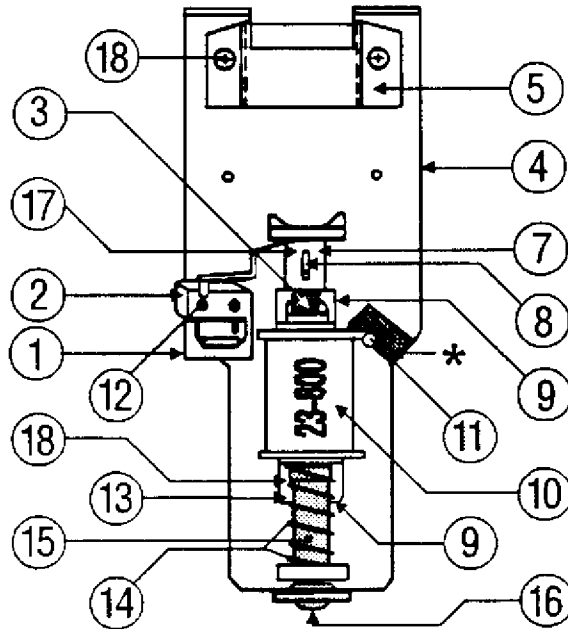

Item	Description	Part No.
1	Switch Insulator	535-5051-00
2	Microswitch	180-5064-01
3	Cap Spring	266-5025-00
4	Ball Kickup Mounting Bracket	535-5298-00
5	Ball Guide Bracket	535-6047-00
6	#6-32 x 3/8 SEMS (2)*	232-5201-00
7	Vertical Kicker Cap	545-5227-00
8	Pin 3/32 x 7/16	251-5004-00
9	Rear Coil Retainer Bracket (2)	535-5203-03
10	Coil 23-800	090-5001-01
11	1N4004 Diode	112-5003-00
12	2-56 x 1/2 Screw (2)	237-5806-00
13	#6-32 x 1/4 Phil. M.S.	232-5200-00
14	Spring	266-5009-00
15	Plunger Assembly	515-5352-00
16	Bumper	545-5105-00
17	Compression Ring (3)	270-5010-00
18	#6-32 x 1/4 SEMS (3)	232-5200-00

* In Figure Above: Insulator Tape to prevent short. No Part Number.

Super VUK/Scoop Assembly 500-5716-00

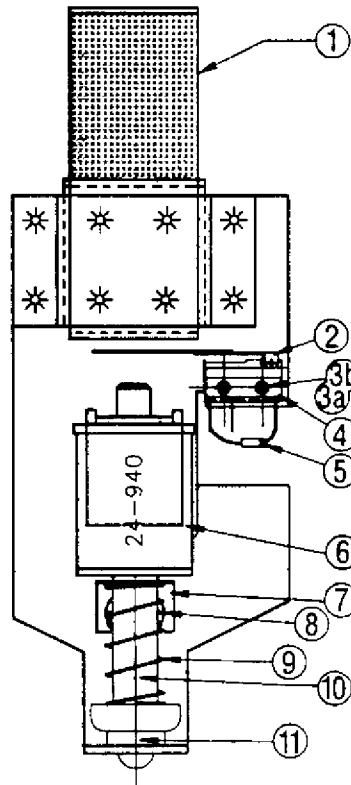

Item	Description	Part No.
1	Weld Assembly	515-5861-00
2	Switch	180-5116-00
3a	Screw (2)	237-5806-00
3b	Washer (2)	244-5001-00
4	Protector	535-6539-00
5	Diode	112-5001-00
6	Coil 24-940	090-5036-00
7	Bracket	535-5203-01
8	Screw (2)	232-5300-00
9	Spring	266-5020-00
10	Plunger	515-5941-00
11	Bumper Pad	545-5458-00

Ball Deflector 500-5788-00

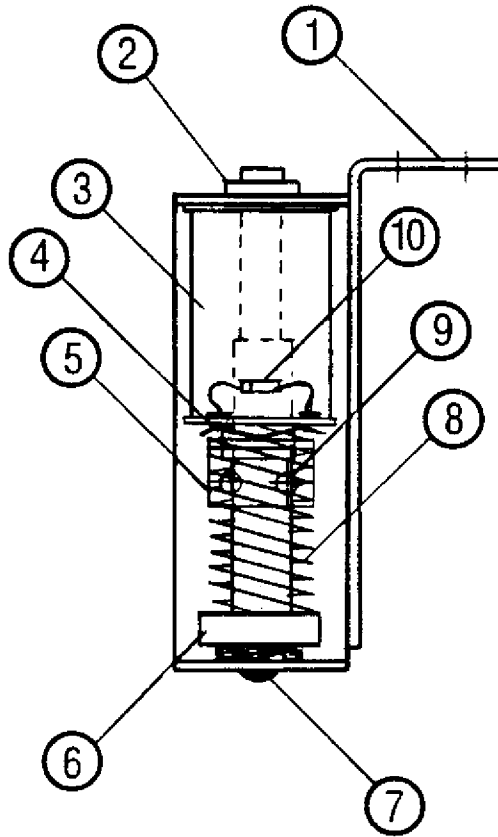

Item	Description	Part No.
1	Ball Deflector Bracket	535-6857-00
2	Coil Sleeve	545-5076-00
3	Coil 27-1500	090-5004-00
4	Wave Washer	269-5002-00
5	Coil Retaining Bracket	535-5203-03
6	Plunger Assembly	515-5941-00
7	Rubber Bumper	545-5105-00
8	Compression Spring	266-5020-00
9	#8-32X 1/4 PH. Pan Sems	232-5300-00
10	Diode 1N4004	112-5003-00

Motor, Cam & Switch Assembly 500-5742-01

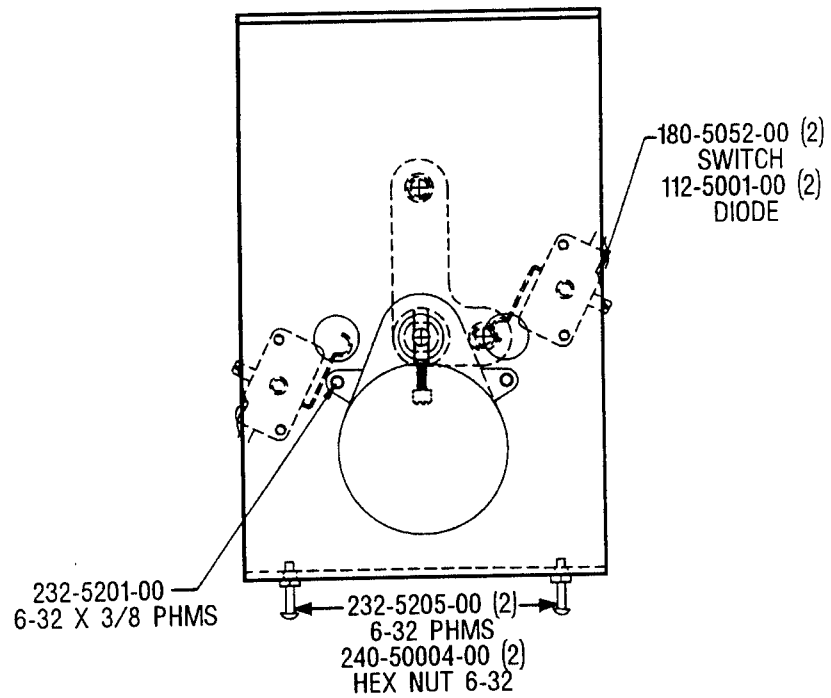
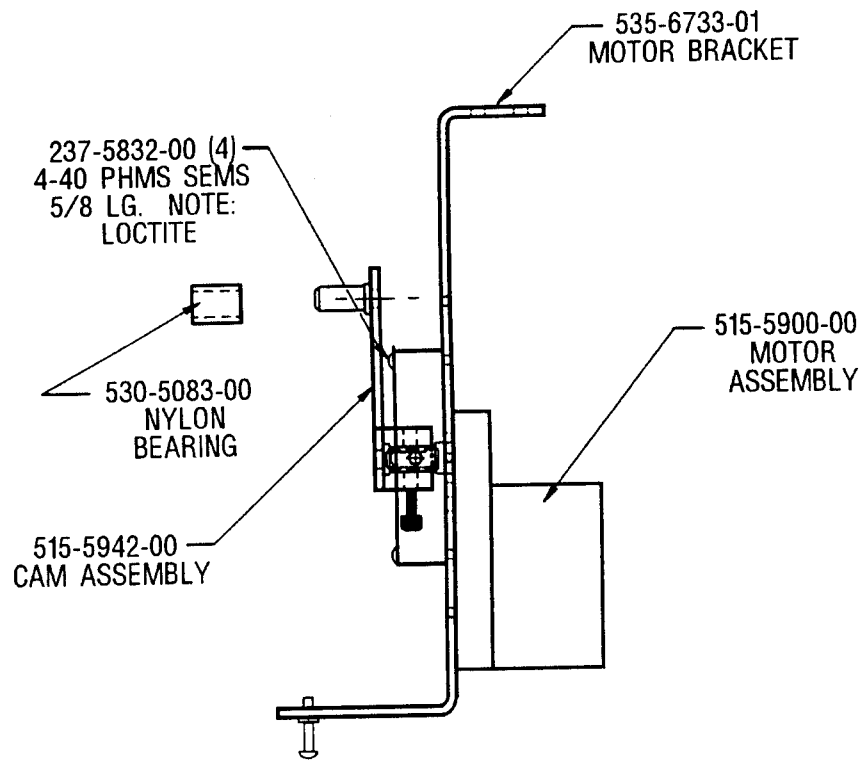

Target Back Plate Guide Assembly 515-5905-XX

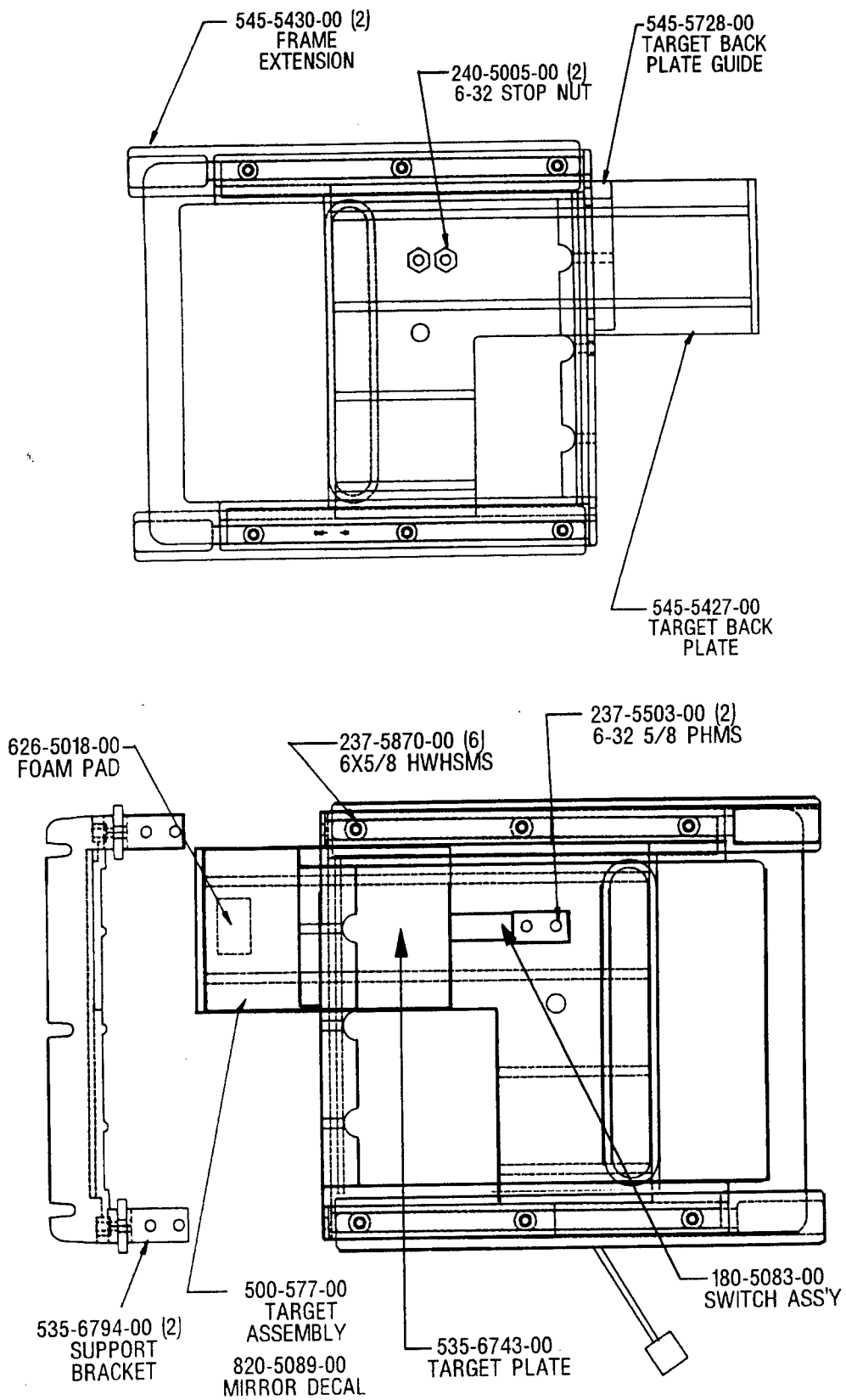

Unique Parts

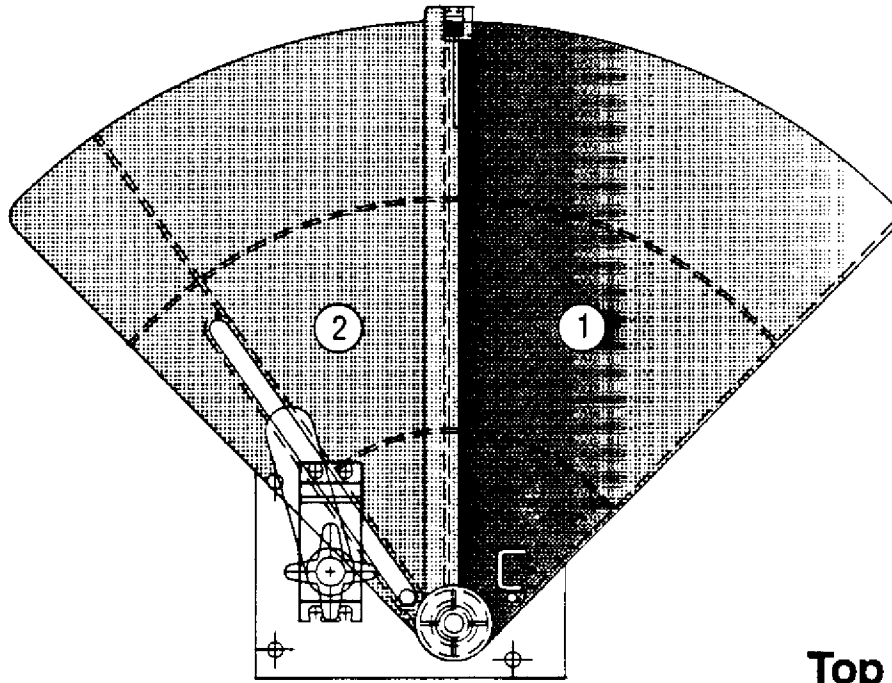

**Top View
Blinder Assembly
500-5775-00
Side View**

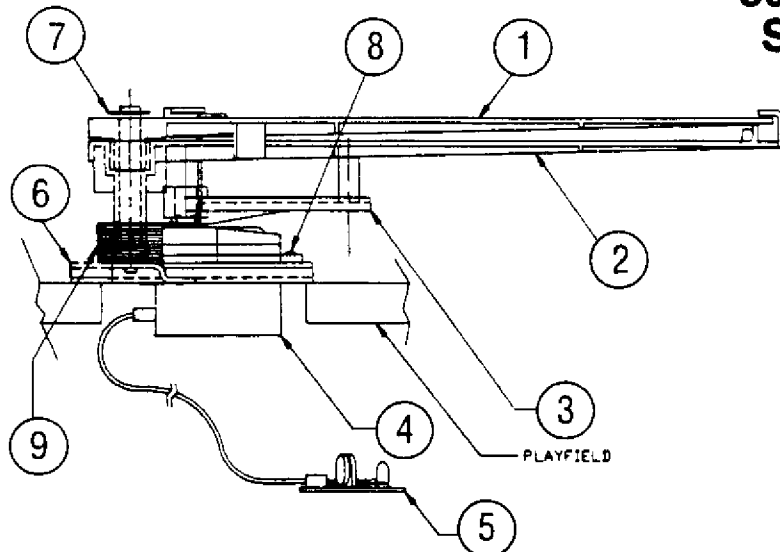

Item	Description	Part No.
1	Blinder Blade Top	545-5453-00
2	Blinder Blade Bottom	545-5454-00
3	Blinder-Support Arm Assembly	515-5922-00
4	Servo-Motor Airtronics *	041-5032-00
5	Servo-Motor Driver Board	520-5078-00
6	Servo Mounting Bracket Assembly	515-5938-00
7	1/4 Truarc E-Ring	270-5002-00
8	4-40X1/2 PH Pan HD Sems	237-5813-00
9	Torsion Spring	266-5039-00

Airplane (Bomber) Assembly 515-5949-00

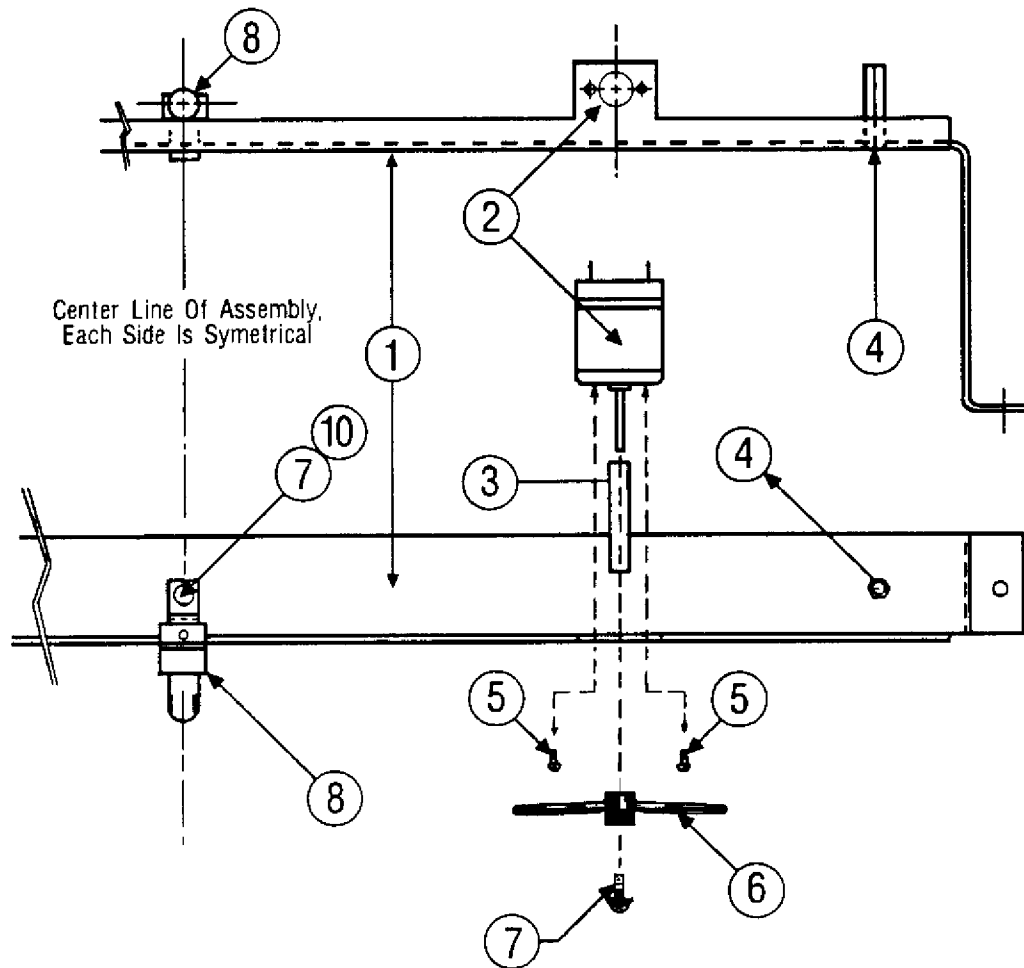

Item	Description	Part No.
1	Plane Under Carriage	535-6748-00
2	D.C. Motor X2	041-5033-00
3	Propeller Shaft X2	530-5268-00
4	1" Hex Spacer X2	254-5008-06
5	4-40 X 3/16 PH Pan Steel Tapite X4	237-5912-00
6	Propeller (Butyrate) X2	830-5457-18
7	6-32 X 3/8 P.R.U.M.S. Sems	232-5201-00
8	Socket -Bulb Assembly X2	518-5026-00
9	Plane Harness (Cable) **	036-5333-00
10	No. 6-32 Hex Nut (KEPS) X2	240-5008-00
11	Plane Bomber (Shell) **	545-5433-00

** Indicates item not shown.

THIS CONFIGURATION FOR 115V

FOR LOWER LINE VOLTAGES
OR 220 VOLT OPERATION
SEE SAMPLES BELOW

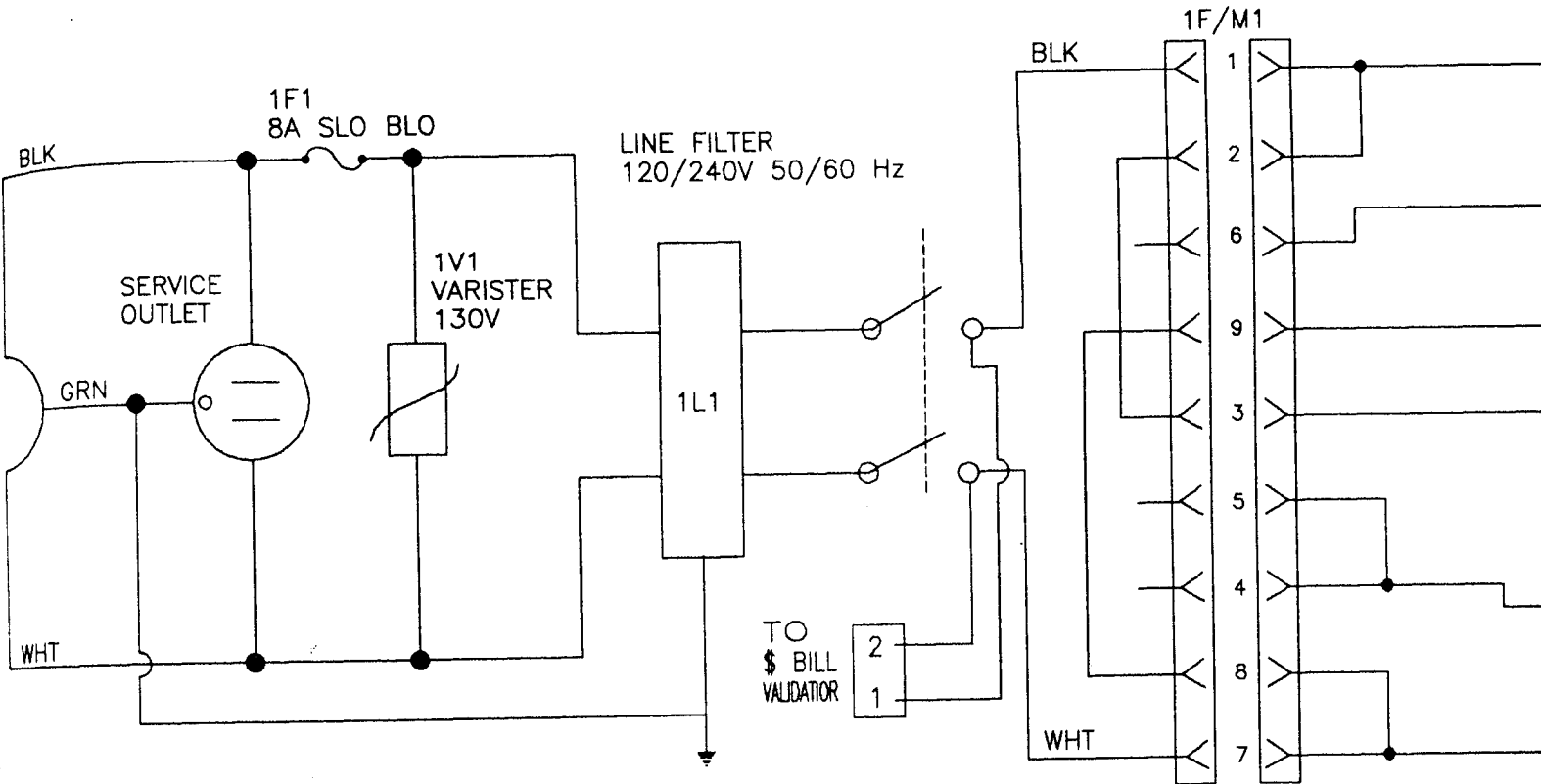

JUMPER FOR VOLTAGE VARIATION

230/218/206 VOLTS

1F1 = 4A SLO BLO
1V1 = 275V VARISTOR

100/105 VOLTS

1F1 = 8A SLO BLO
1V1 = 130V VARISTOR

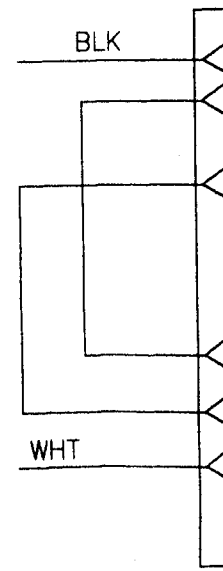
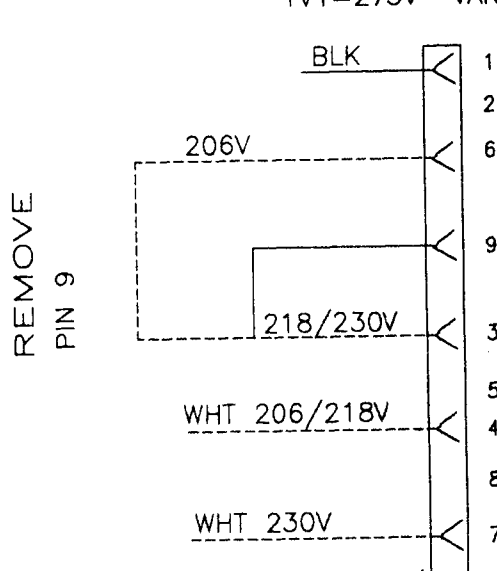

5V

1T1

1F/M2

CN1

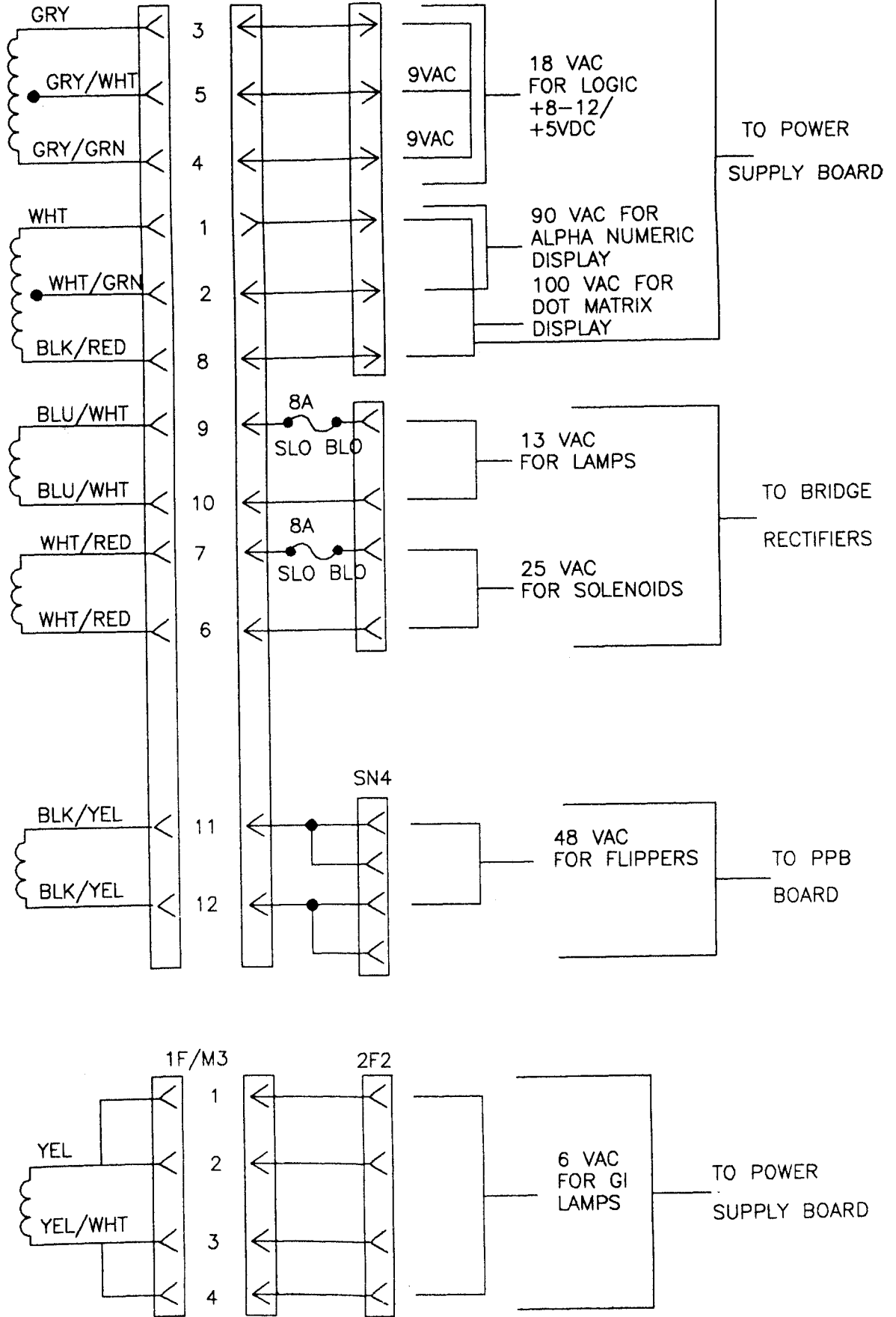

ON

VOLTS

SLO BLO
VARISTOR

K

- 1
- 2
- 6
- 9
- 3
- 5
- 4
- 8
- 7

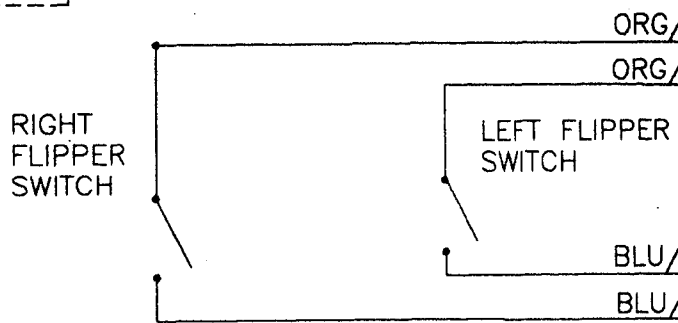
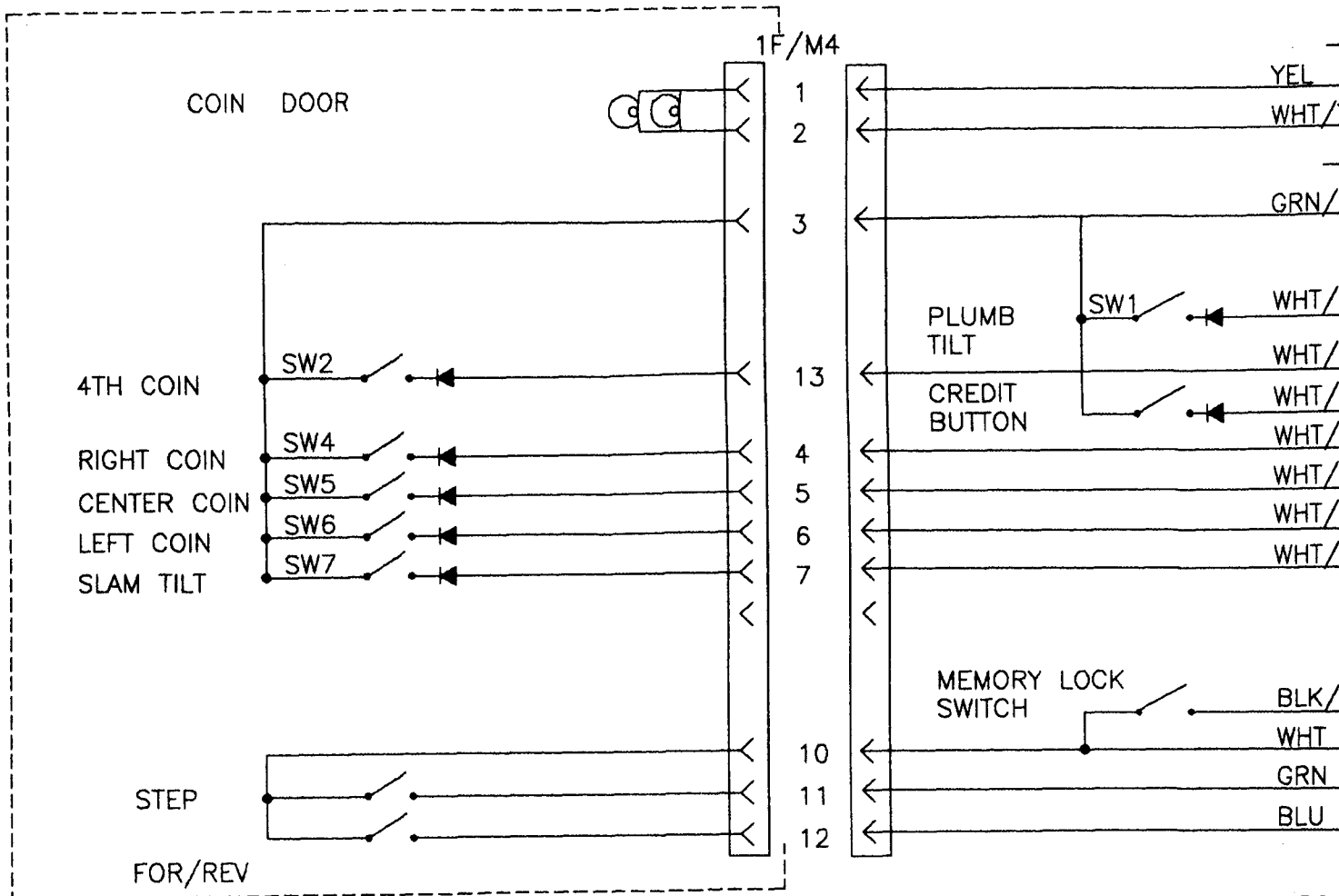

CABINET SPEAKER MONO

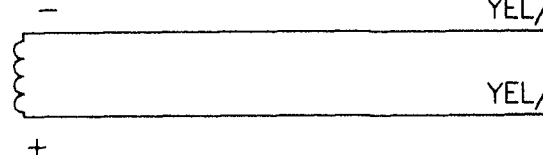

STEREO VOLUME CONTROL 10K LOGARITHMIC

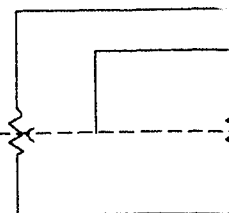

LEFT CHANNEL

1M/F

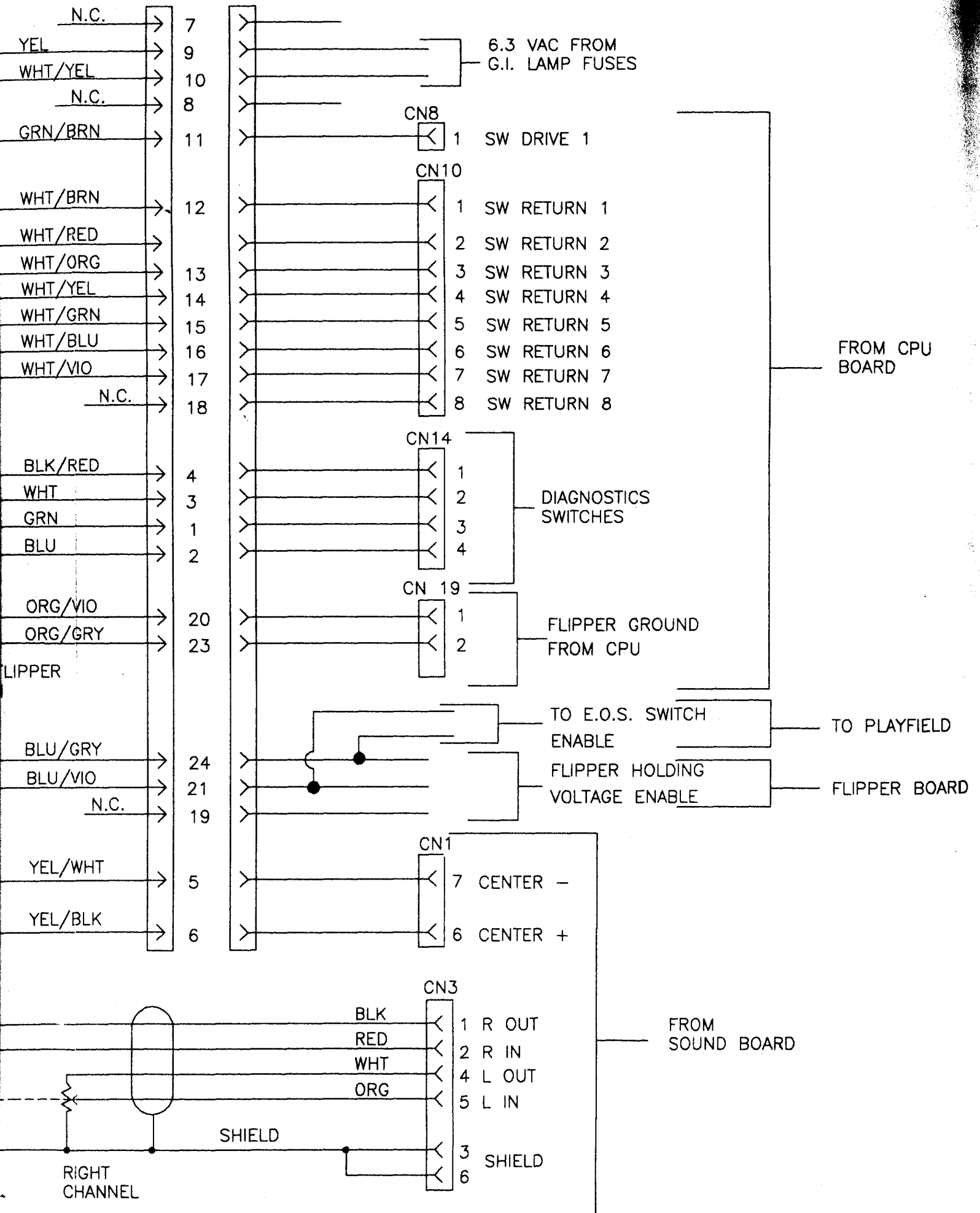

CN1-1 +18VDC
 CN1-2 +34VDC
 CN1-3 GND
 CN2-3 GND
 CN2-6 GND
 25VAC FOR SOLENOIDS FROM POWER
 13VAC FOR LAMPS WIRING DIAGRAM

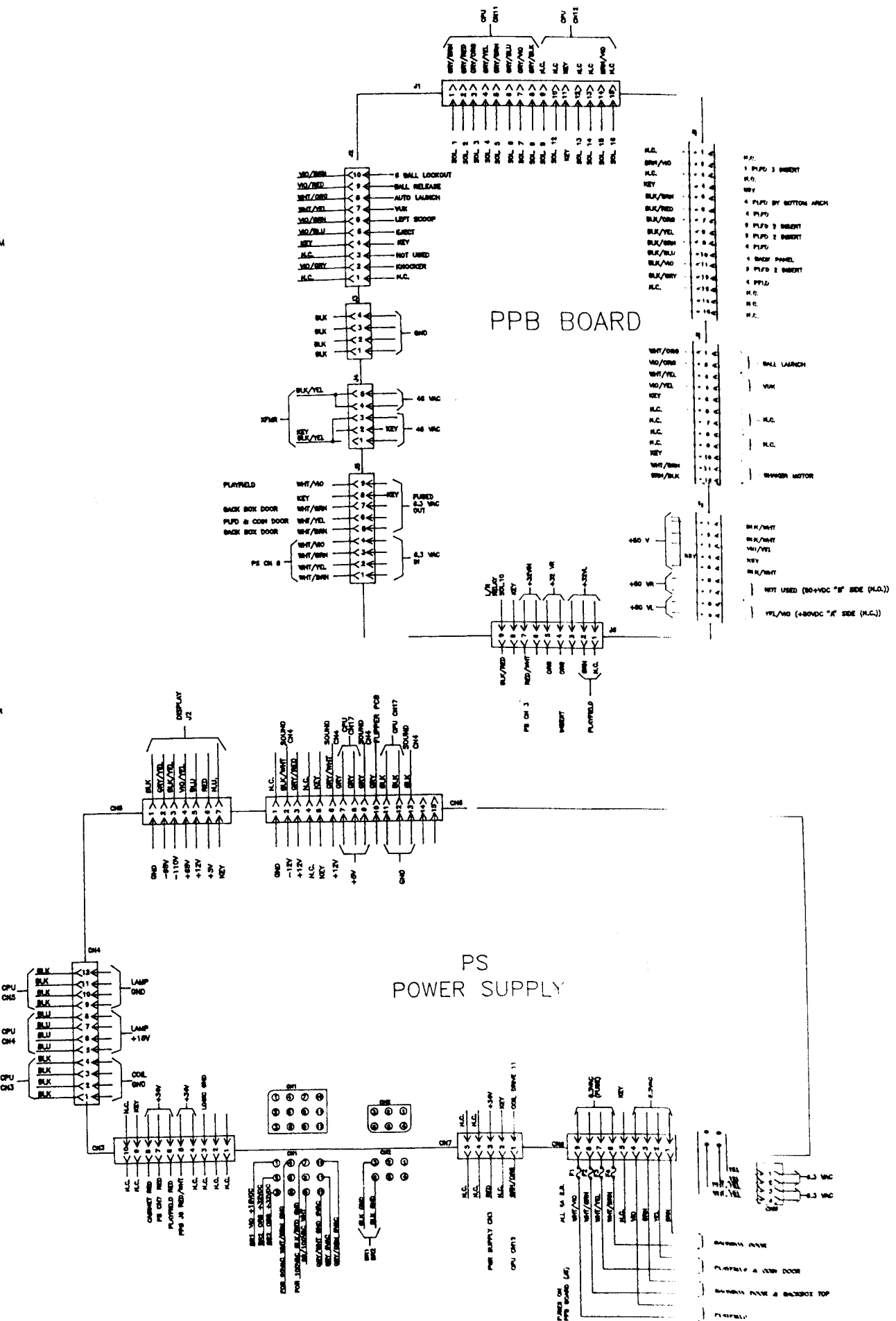
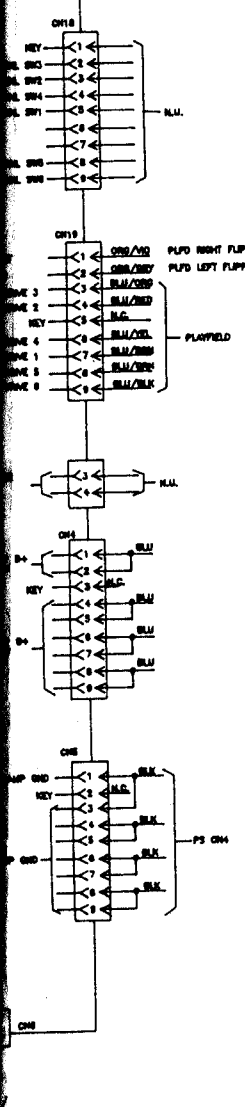

Backbox Wiring Diagram.....

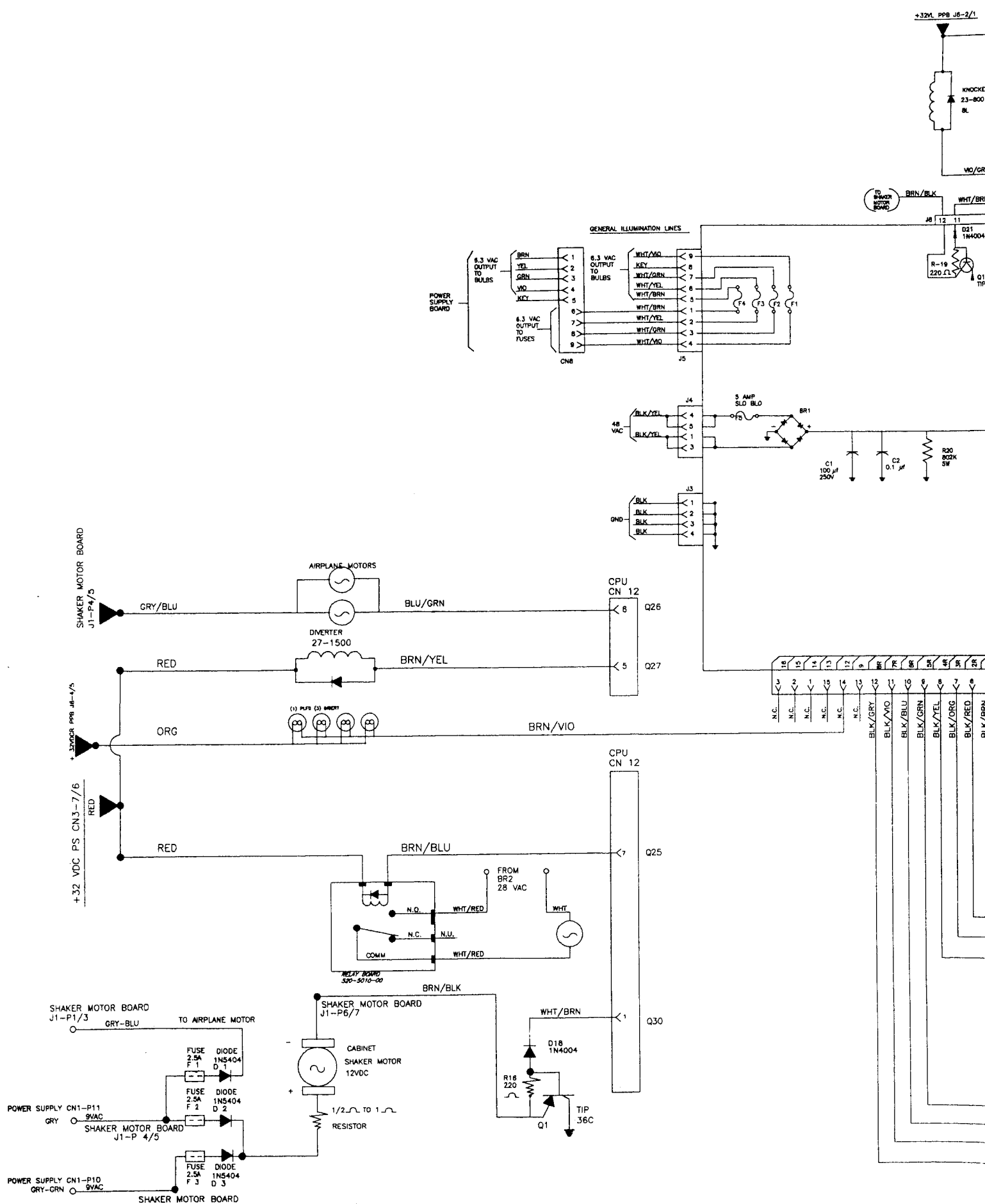

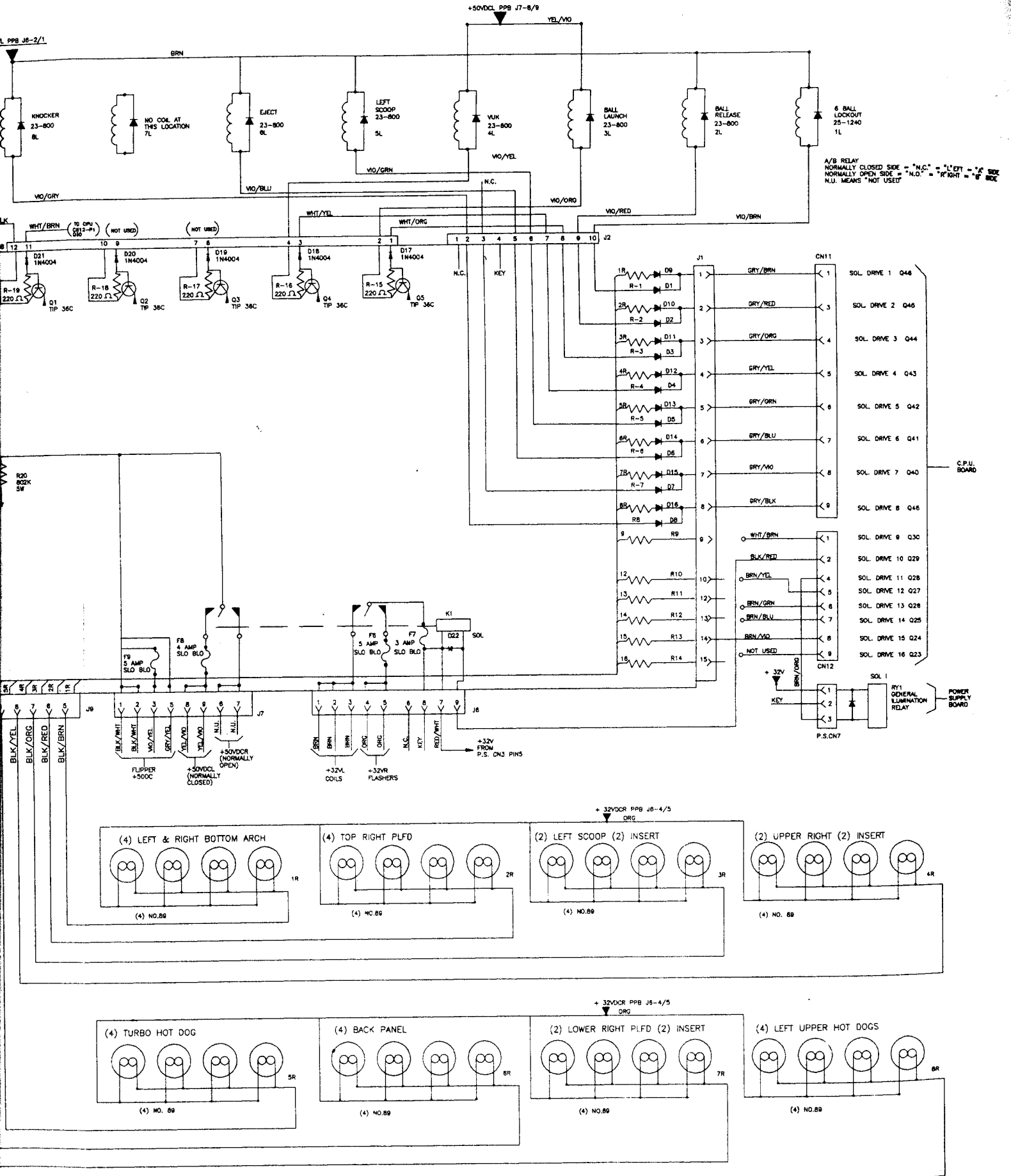

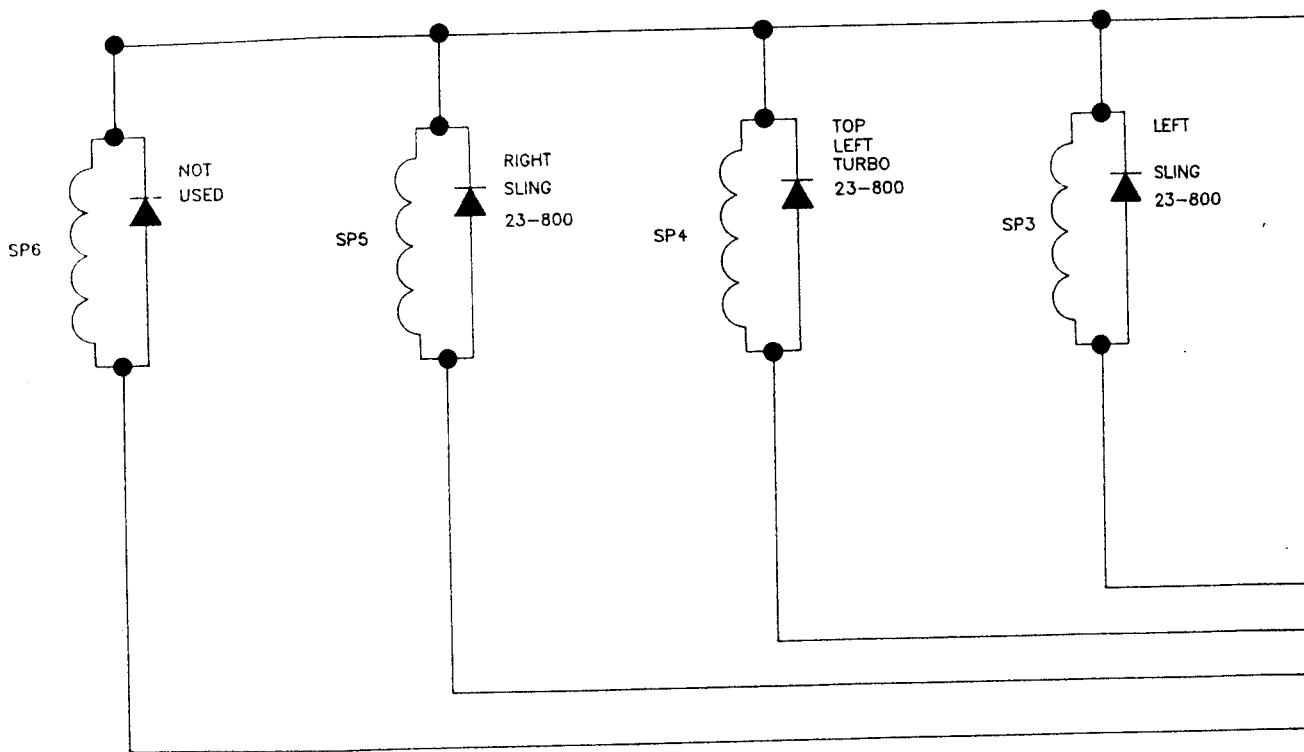

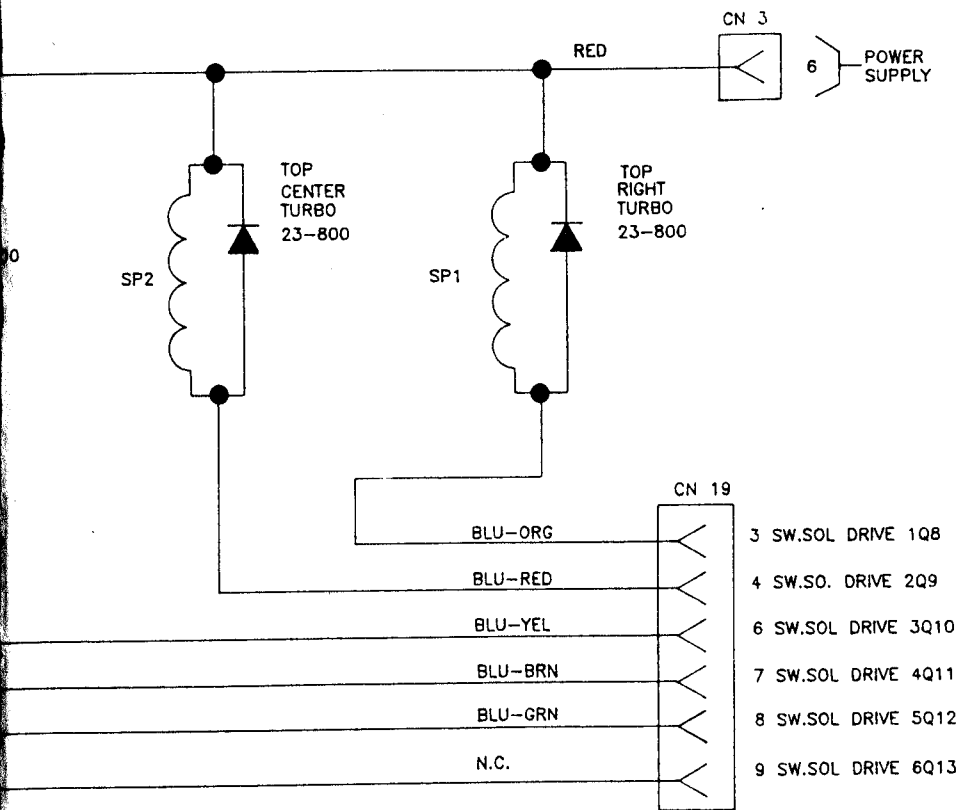

Switch Matrix No. & Description		Part No.
01*	Plumb Tilt	See Cabinet
02*	4th Coin (On Coin Door)	---
03*	Credit Button (Left of Coin Door)	500-5097-02
04*	Right Coin (On Coin Door)	180-5024-00
05*	Center Coin (On Coin Door)	180-5024-00
06*	Left Coin (On Coin Door)	180-5024-00
07*	Slam Tilt	180-5022-00
08*	Extra Ball Button (Under 03)	180-5073-00
09	Ball Trough #1 Left	180-5119-00
10	Ball Trough #2	180-5119-00
11	Ball Trough #3	180-5119-00
12	Ball Trough #4	180-5119-00
13	Ball Trough #5	180-5119-00
14	Ball Trough #6	180-5119-00
15	Ball Trough #7 Right	180-5118-00
16	Shooter Lane	180-5100-01

Switch Matrix No. & Description		Part No.
17	Left Slingshot	180-5023-00
18	Right Slingshot	180-5023-00
19	VUK Microswitch	180-5064-00
20	Left Ramp Stand-Up LEFT	515-5967-08
21	Left Ramp Stand-Up RIGHT	515-5967-08
22	Right Ramp Stand-Up	515-5967-08
23	Left Scoop	180-5116-00
24	Silver Ball Target	515-5932-00
25	Left 3-Bank Stand-Up Bottom	515-5966-06
26	Left 3-Bank Stand-Up Middle	515-5966-07
27	Left 3-Bank Stand-Up Top	515-5966-03
28	Mirror Up	180-5052-00
29	Top Left Rollover	500-5706-00
30	Right Ramp Enter	180-5090-00
31	Mirror Down	180-5052-00
32	Mirror Target	180-5083-00

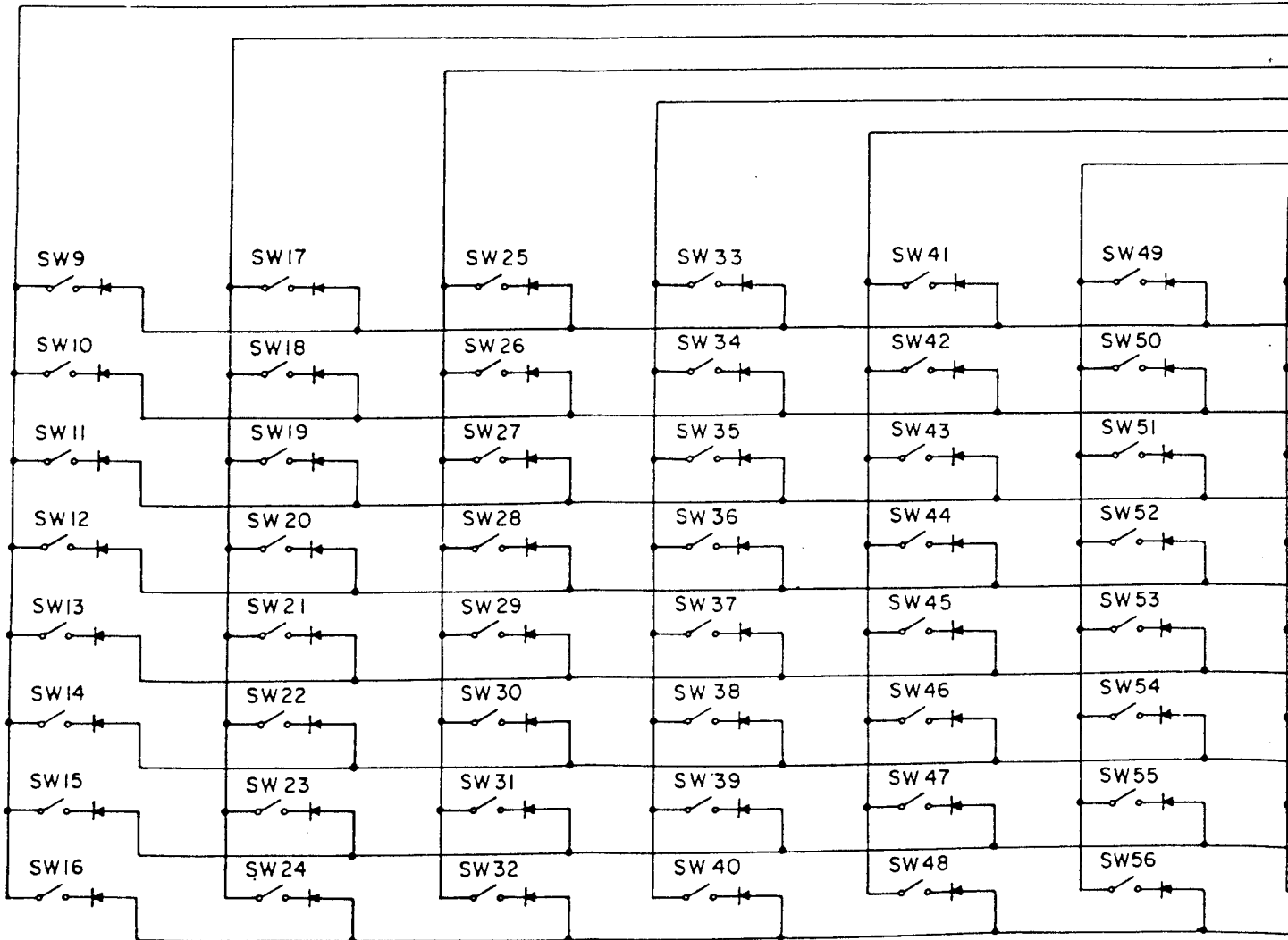

-00
 -00
 -00
 -08
 -08
 -08
 -00
 -00
 -06
 -07
 -03
 -00
 -00
 -00
 -00

Switch Matrix No. & Description	Part No.
33 Right 3-Bank Stand-Up Top	515-5966-03
34 Right 3-Bank Stand-Up Middle	515-5966-07
35 Right 3-Bank Stand-Up Bottom	515-5966-06
36 Left Return Lane	500-5707-00
37 Right Return Lane	500-5706-00
38 Middle Stand-Up	515-5966-08
39 Left Spinner	180-5010-04
40 Right Spinner	180-5010-04
41** Mirror Trough	180-5057-00
42** Skill Trough	180-5057-00
43 Captive Ball (Target Switch)	180-5114-08
44 Not Used	---
45 Not Used	---
46 Not Used	---
47 Eject (Micro Switch)	180-5027-01
48 Top Right Rollover	500-5706-00

Switch Matrix No. & Description	Part No.
49 Left Turbo Bumper	180-5015-01
50 Center Turbo Bumper	180-5015-01
51 Right Turbo Bumper	180-5015-01
52 Not Used	---
53 Not Used	---
54 Not Used	---
55 Left Outlane	500-5706-00
56 Right Outlane	500-5706-00
57 Left Ramp Enter	180-5090-00
58 Left Ramp Exit	180-5093-00
59 Not Used	---
60 Not Used	---
61 Not Used	---
62 Right Ramp Exit	180-5093-00
63* Left Flipper (Cabinet)	180-5124-00
64* Right Flipper (Cabinet)	180-5124-00

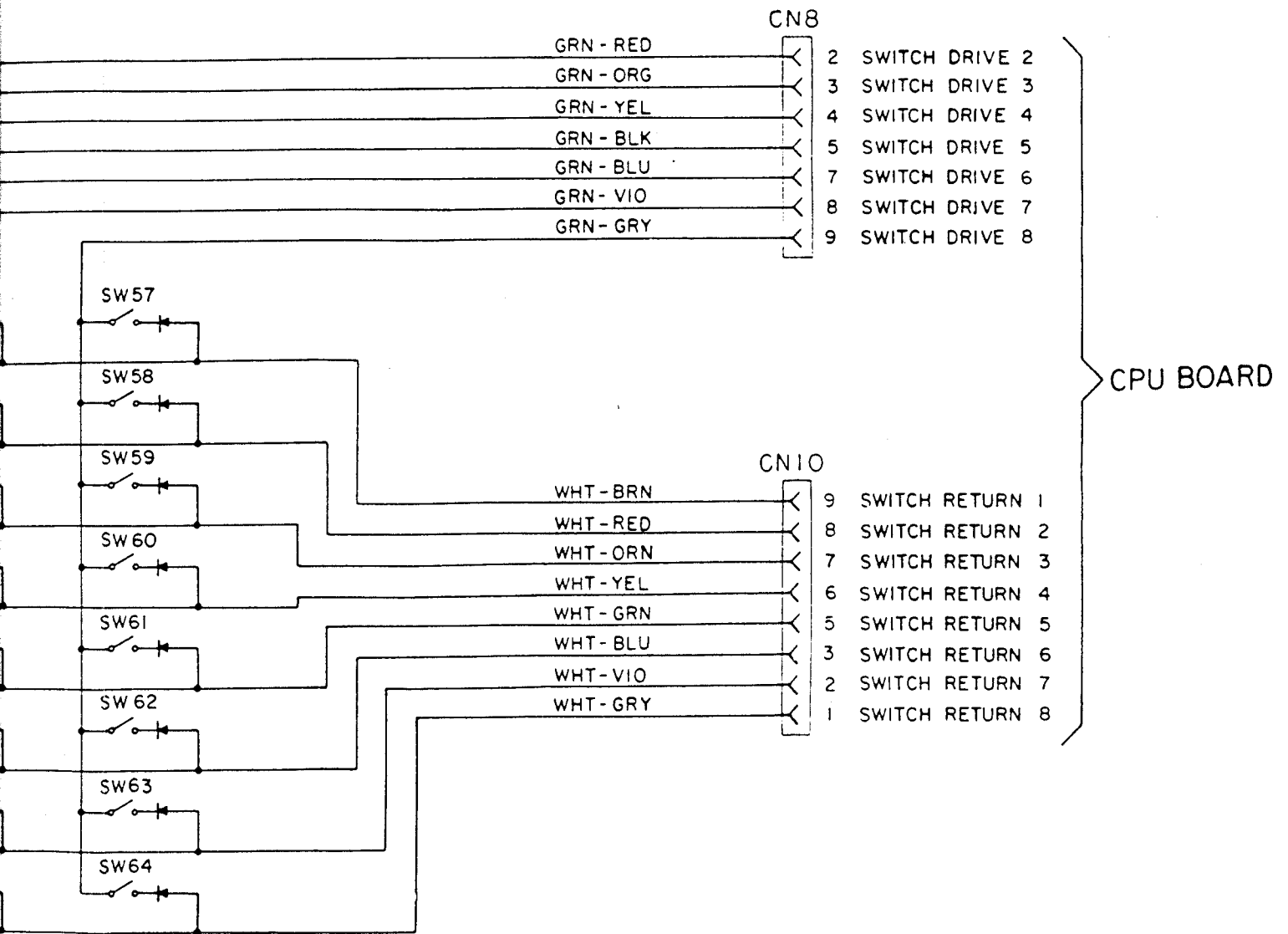

Lamp Matrix No. & Description	
01**	...T (Insert X2)
02	Grid: Christmas
03	Grid: Cousin Kevin
04	Grid: Holiday Camp
05	Grid: Lite Extra Ball
06	Grid: Silver Ball
07	Grid: Captain Walker
08	Grid: Wizard
09	Skill Shot
10**	...O (Insert X2)
11	Grid: Smash the Mirror
12	Grid: Fiddle About
13	Grid: Acid Queen
14	Grid: There's A Doctor
15	Grid: Tommy Scoring
16	Grid: Sally Simpson

Lamp Matrix No. & Description	
17	Jackpot
18	Double Jackpot
19**	...M (Insert X2)
20	Left Ramp Stand-Up Left
21	Left Ramp Stand-Up Right
22	Left Ramp Stand-Up Top
23*	Extra Ball Button (Cabinet)
24	Silver Ball
25	Left 3-Bank Stand-Up Bottom
26	Left 3-Bank Stand-Up Middle
27	Left 3-Bank Stand-Up Top
28**	...M (Insert X2)
29	Spinner Bonus Left
30	Extra Ball
31	Light Union Jack Left (Spinner)
32	Genius

Lamp Matrix No. & Description	
33	Right 3-Bank Stand-Up
34	Right 3-Bank S.U. Middle
35	Right 3-Bank S.U. Bottom
36	Mystery
37**	...Y (Insert X2)
38	More Time
39	Captain Walker LT (Spinner)
40	Captain Walker RT (Spinner)
41	...T (Playfield)
42	...O (Playfield)
43	...M (Playfield)
44	...M (Playfield)
45	...Y (Playfield)
46	Outlanes X2
47	Mirror Multiball
48	Shoot Again

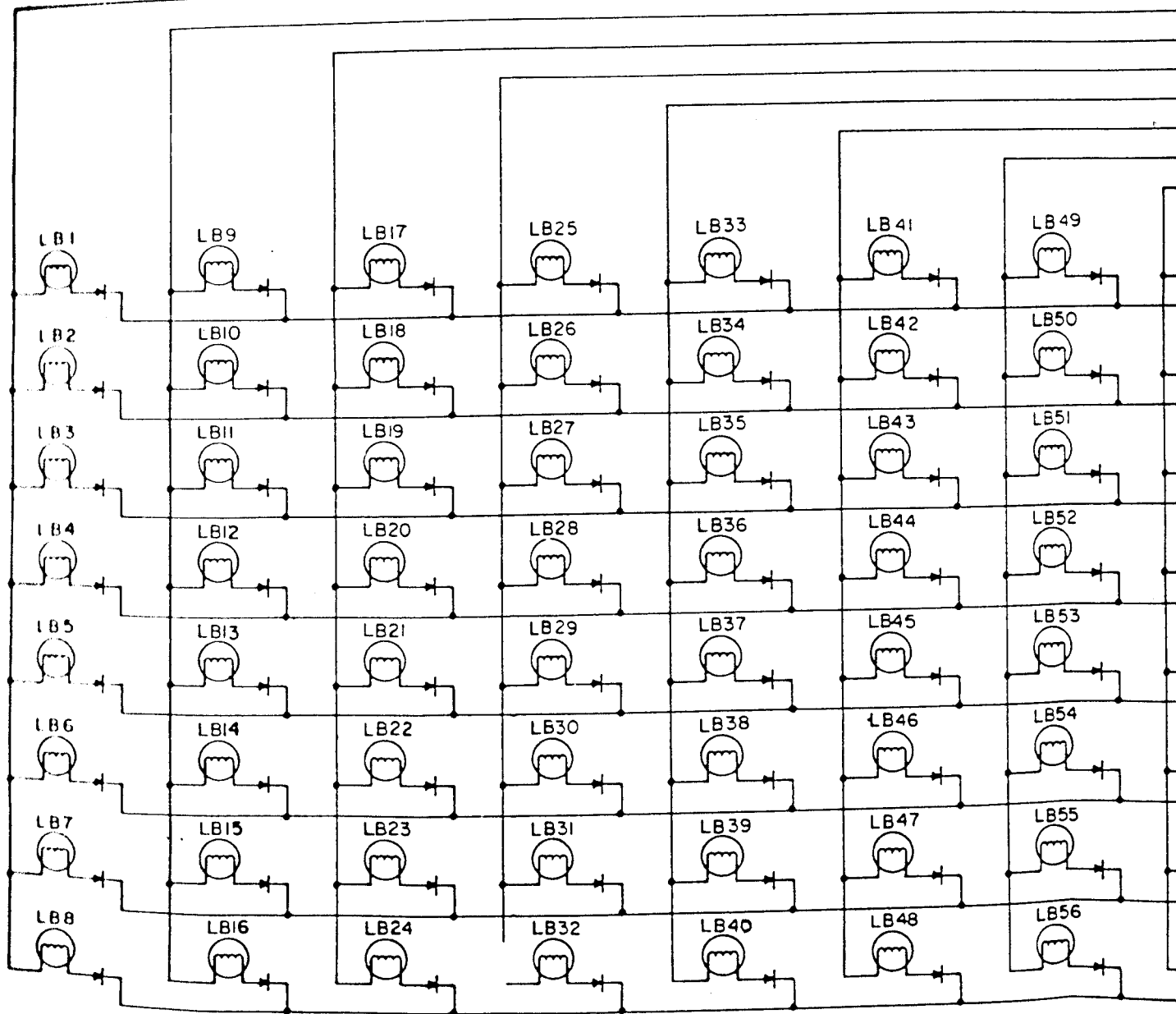

Description
Stand-Up Top
S.U. Middle
S.U. Bottom
Insert X2
LT (See Note 1)
RT (See Note 1)
Playfield
Playfield
Playfield
Playfield
Playfield

Lamp Matrix No. & Description
49 Left Turbo Bumper
50 Center Turbo Bumper
51 Right Turbo Bumper
52 Spinner Bonus
53 Lite Union Jack RT (Spinner)
54 Holiday Camp
55 Return Lanes X2
56 Airplane (See Note 2)
57 Acid Queen Left
58 Acid Queen Center
59 Acid Queen Right
60 Sally Simpson LT (See Note1)
61 Sally Simpson RT (See Note1)
62 Scoop Multiball
63 Collect Union Jack
64* Credit Button (Cabinet)

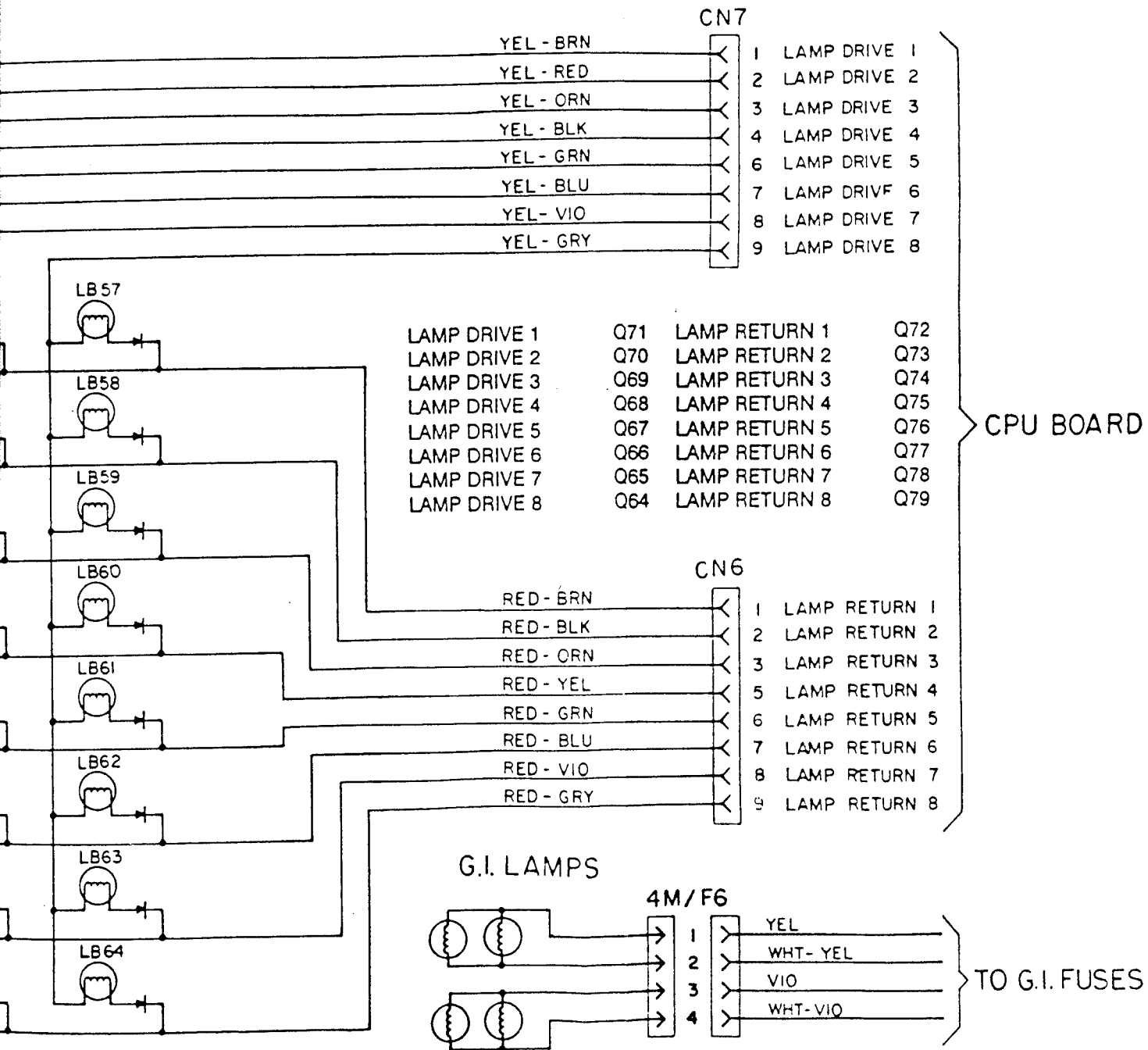

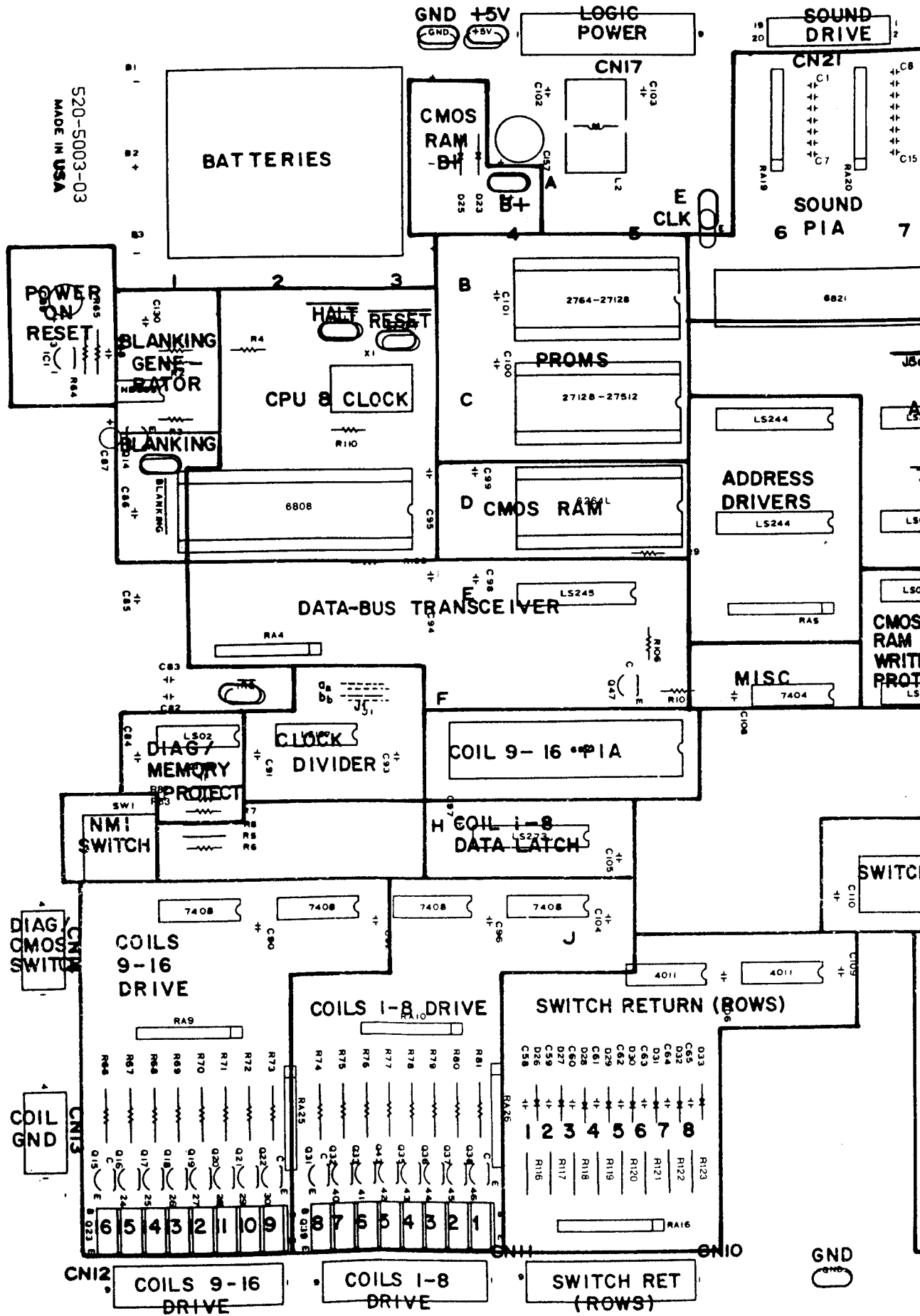

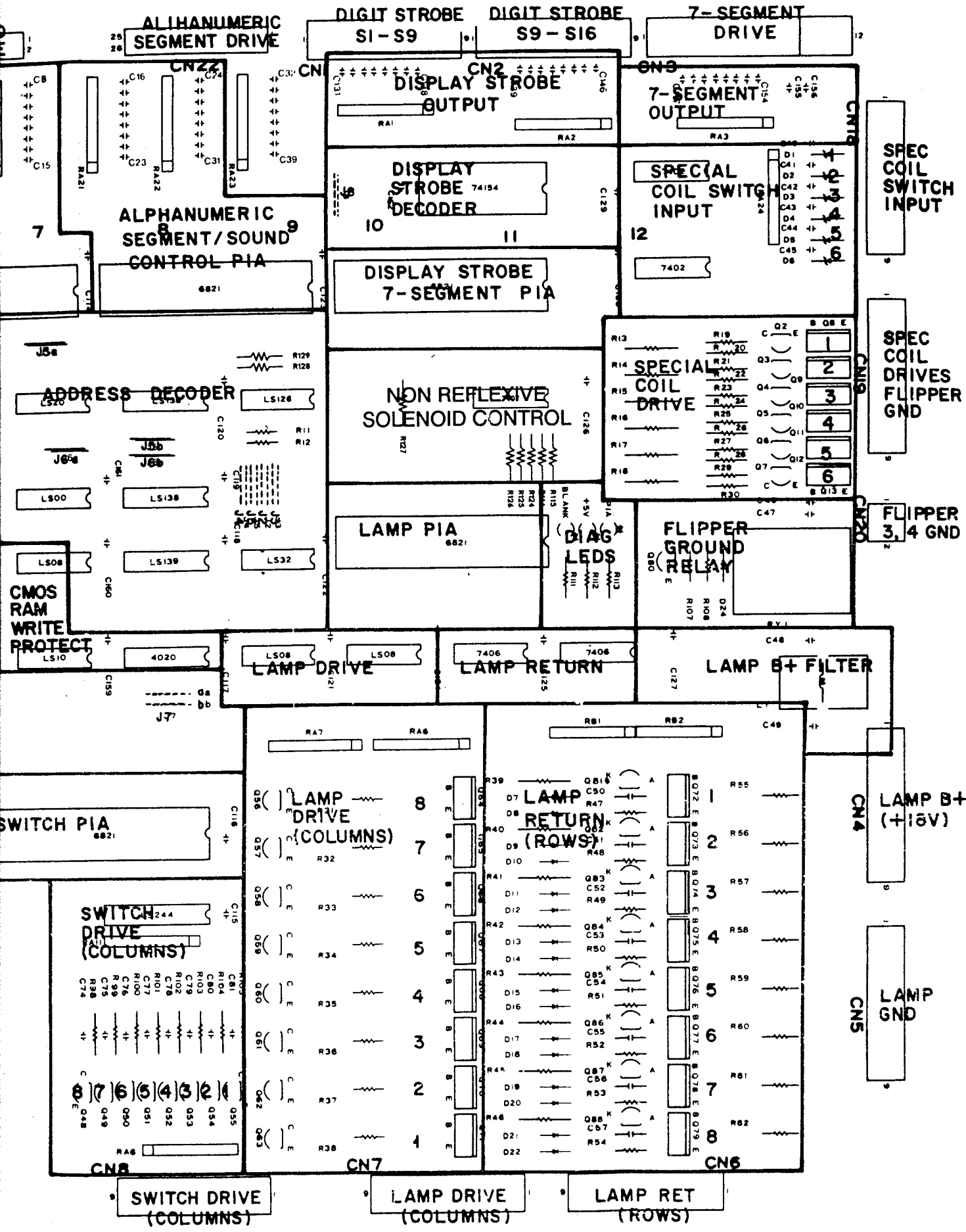

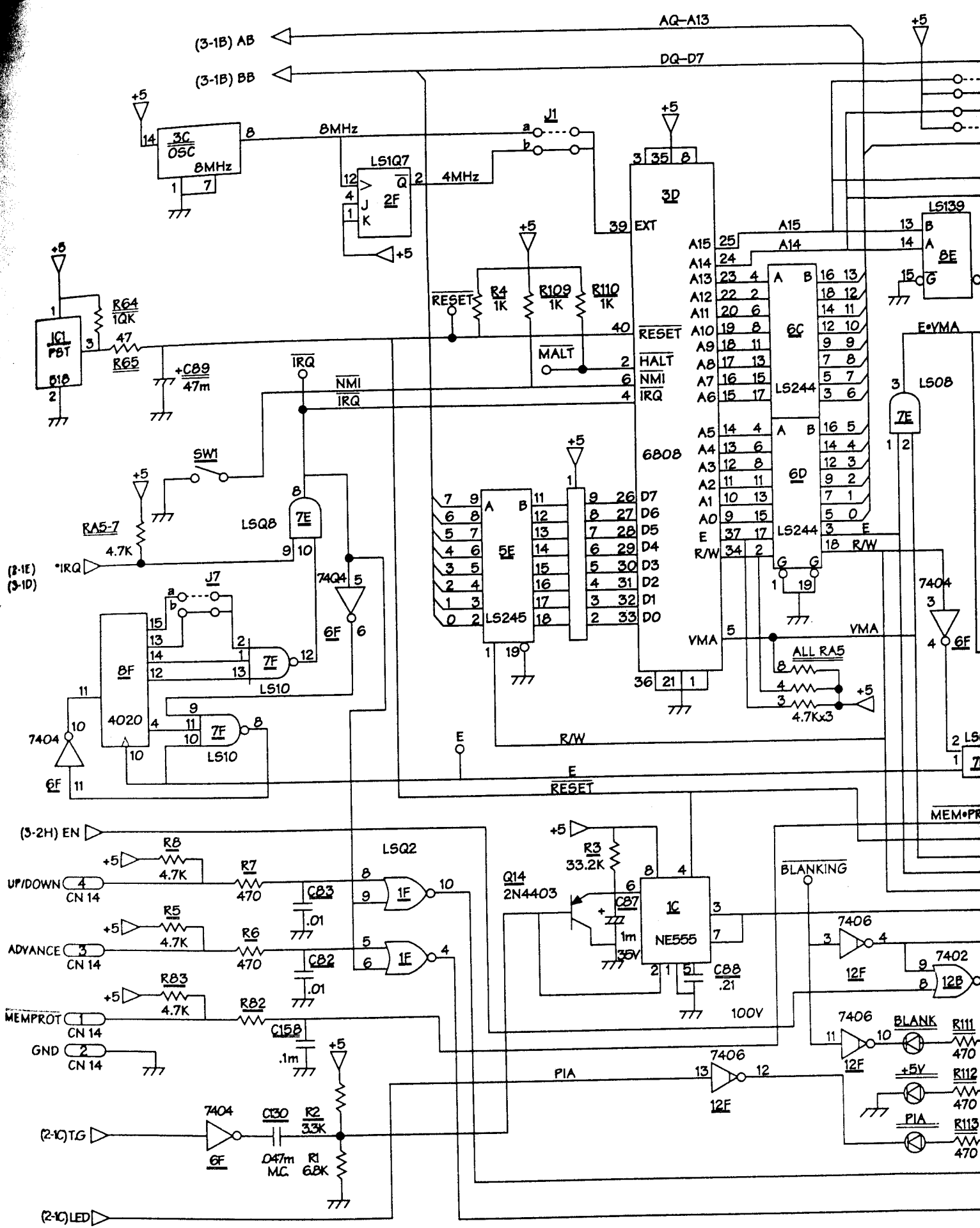

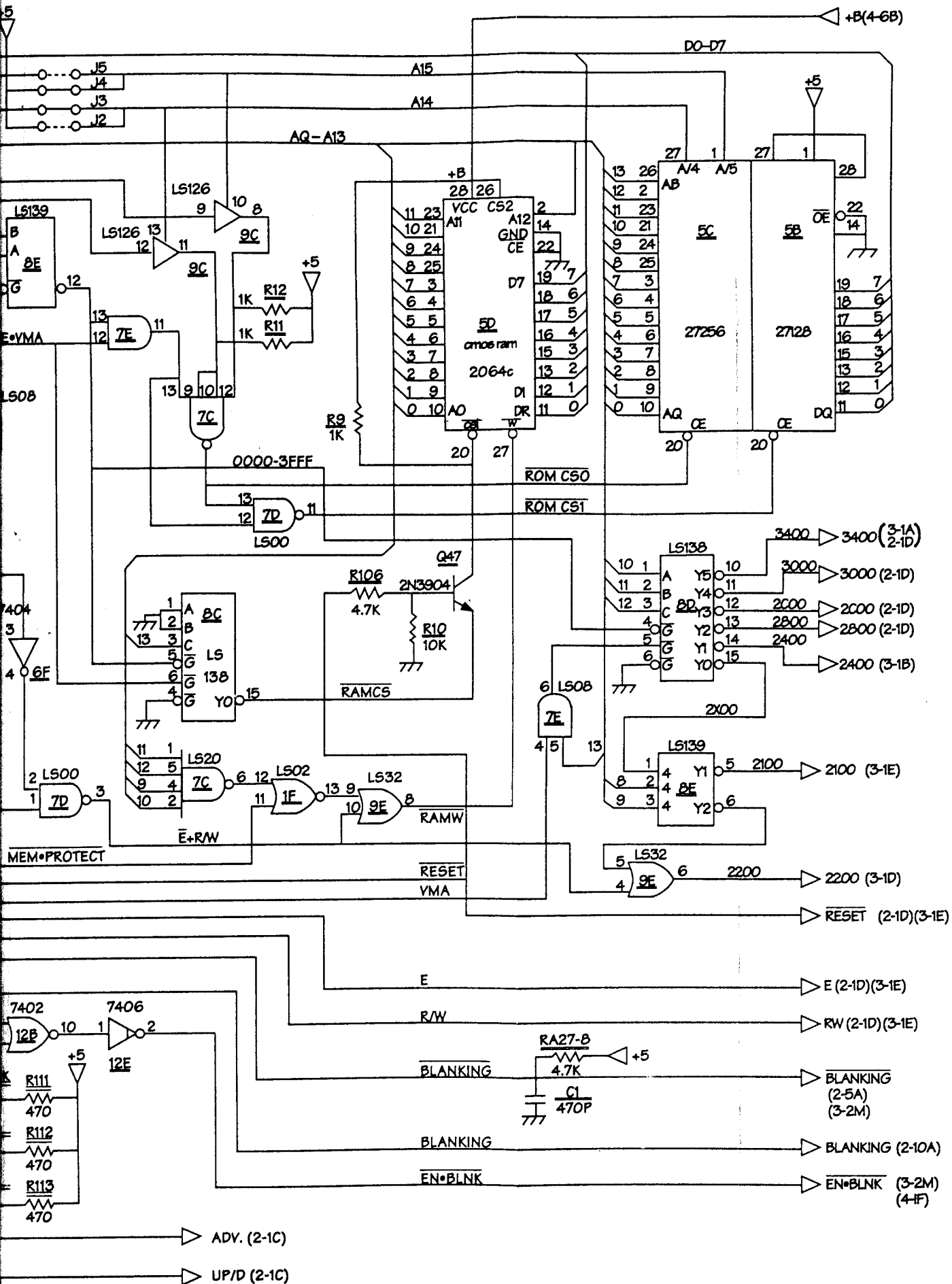

CPU Board Logic Diagram (Sheet 1)69

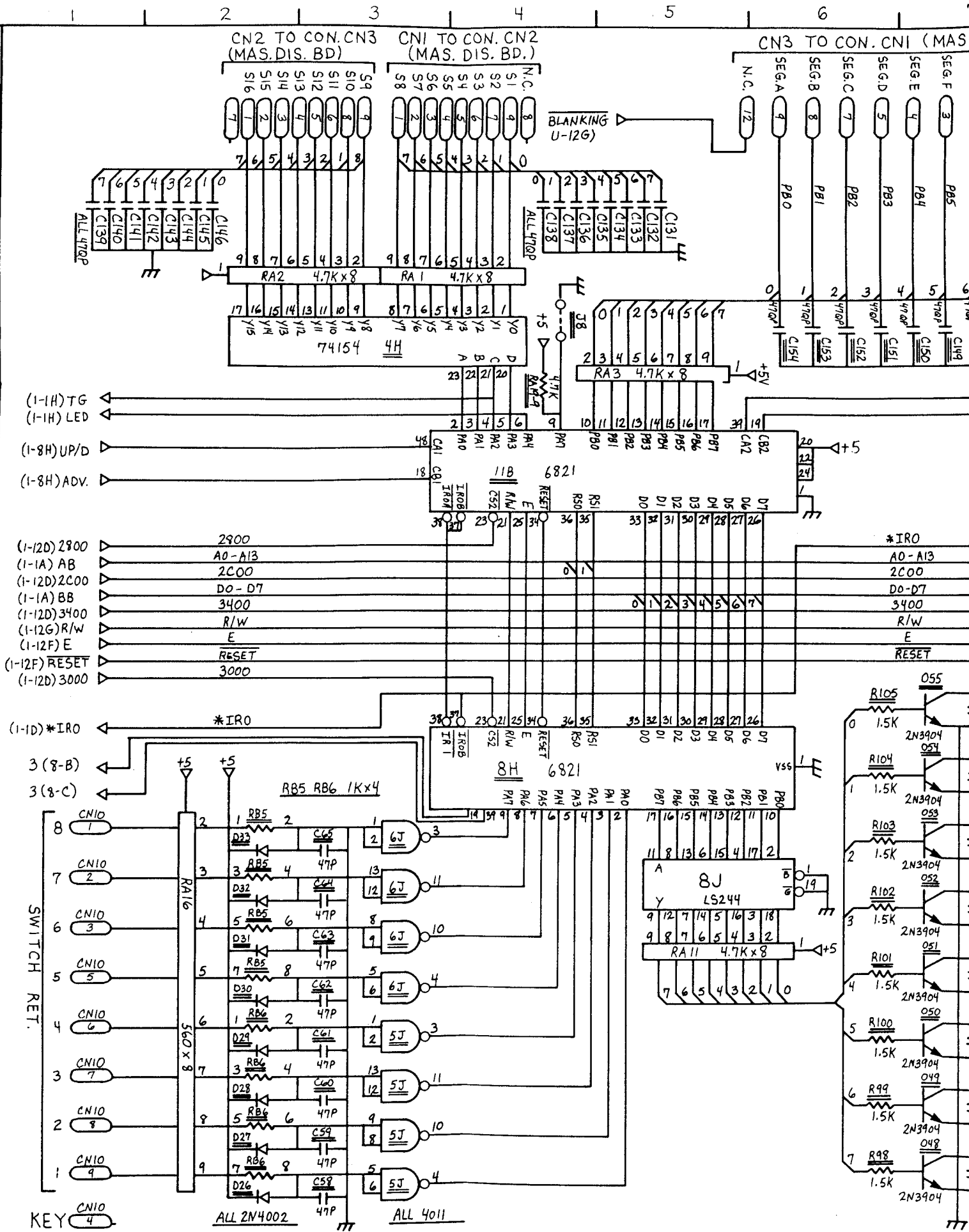

(MAS DIS. BD)

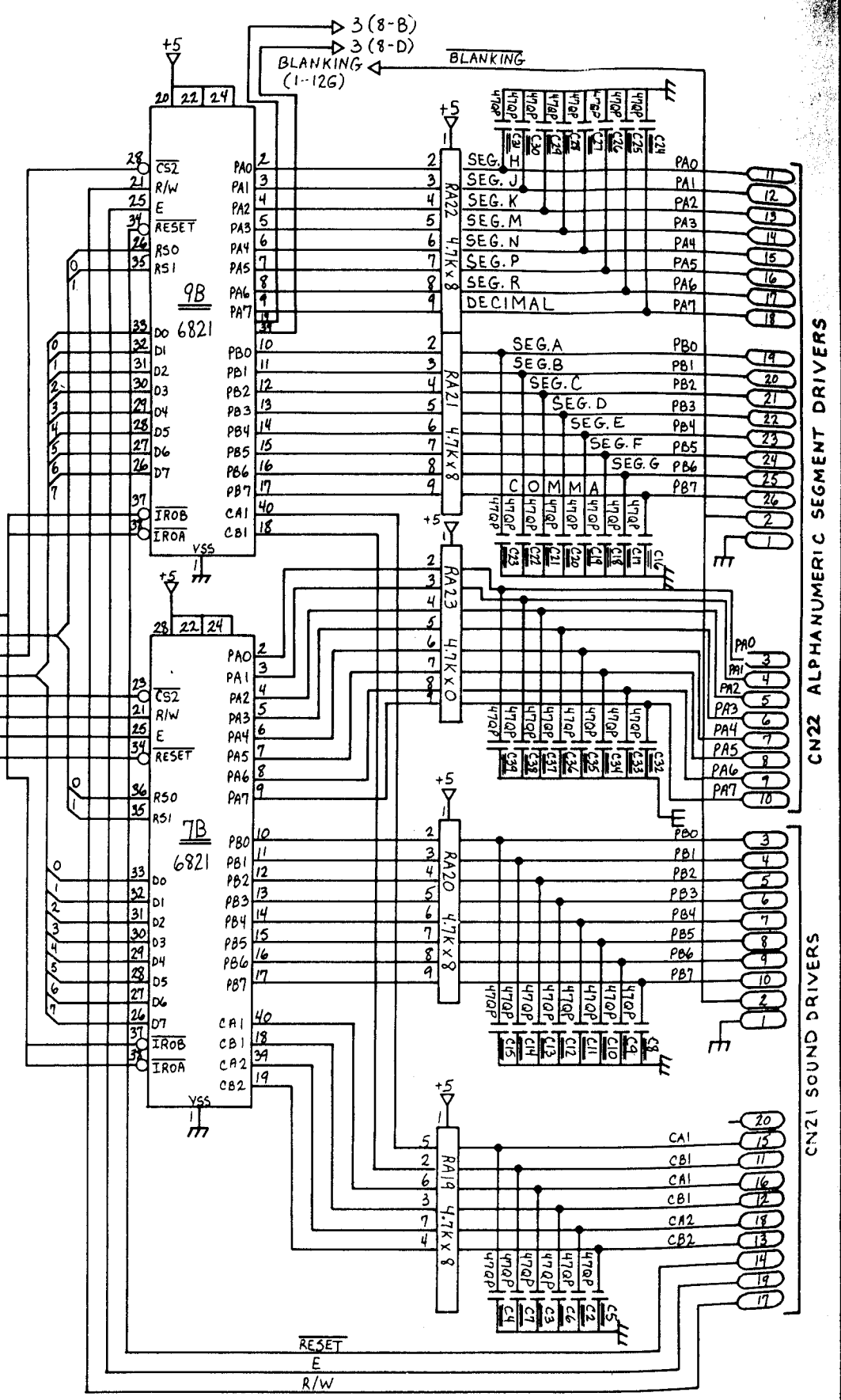
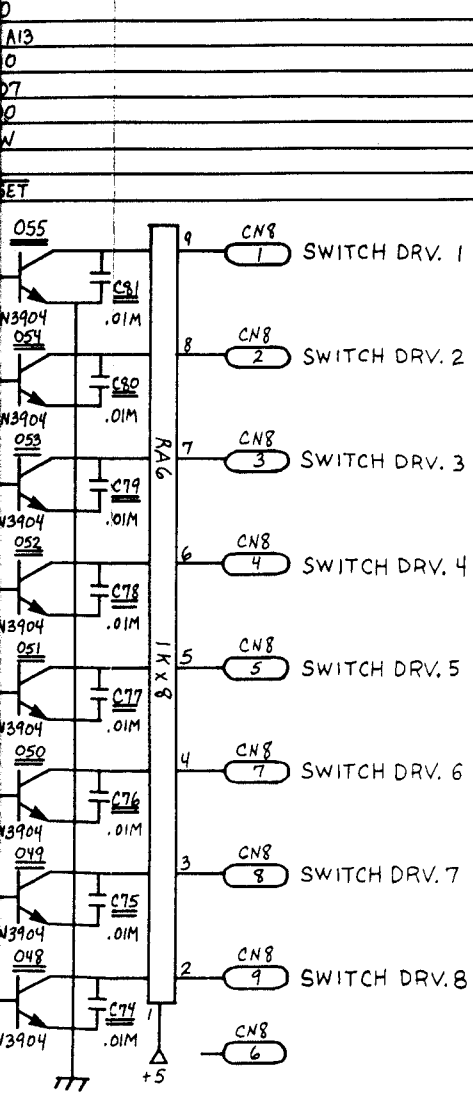
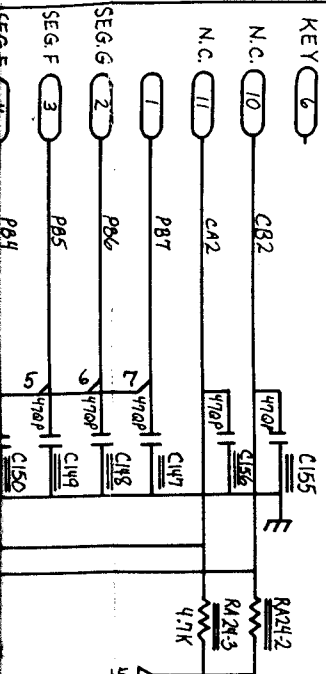

CN22 ALPHANUMERIC SEGMENT DRIVERS

CN21 SOUND DRIVERS

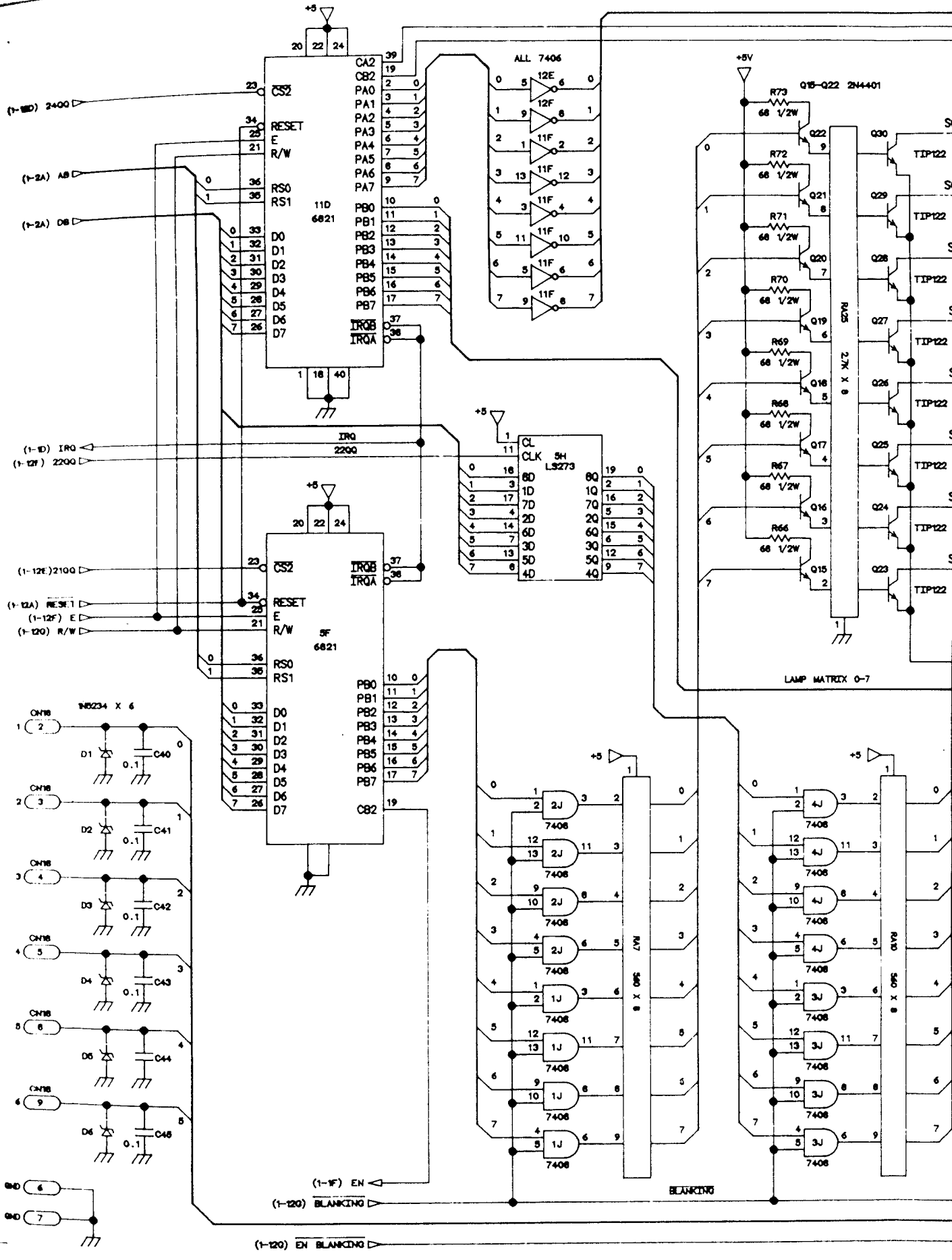

SPECIAL DEL. SWITCH INPUTS

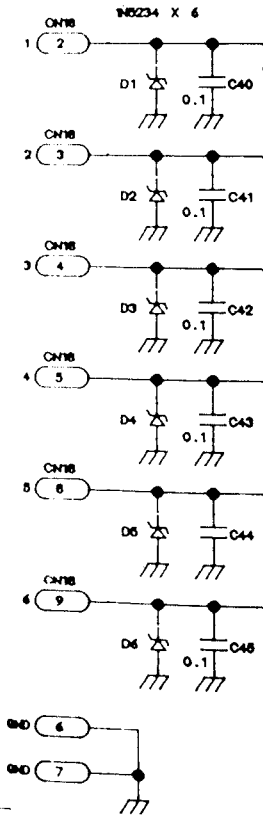

(1-120) EN BLANKING

BLANKING

LAMP MATRIX 0-7

LAMP MATRIX CONT. 0-7

LAMP CNT (4-8A)

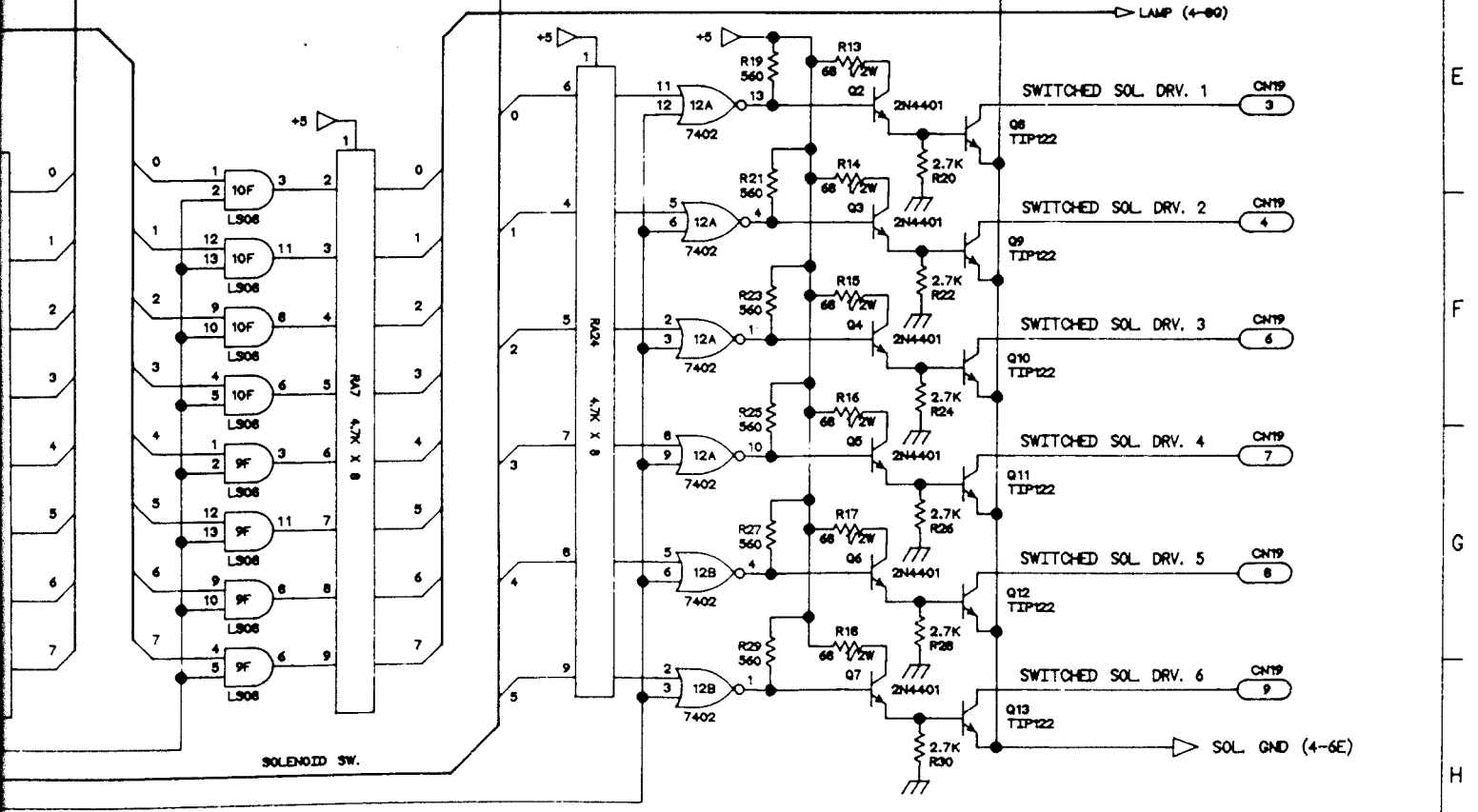
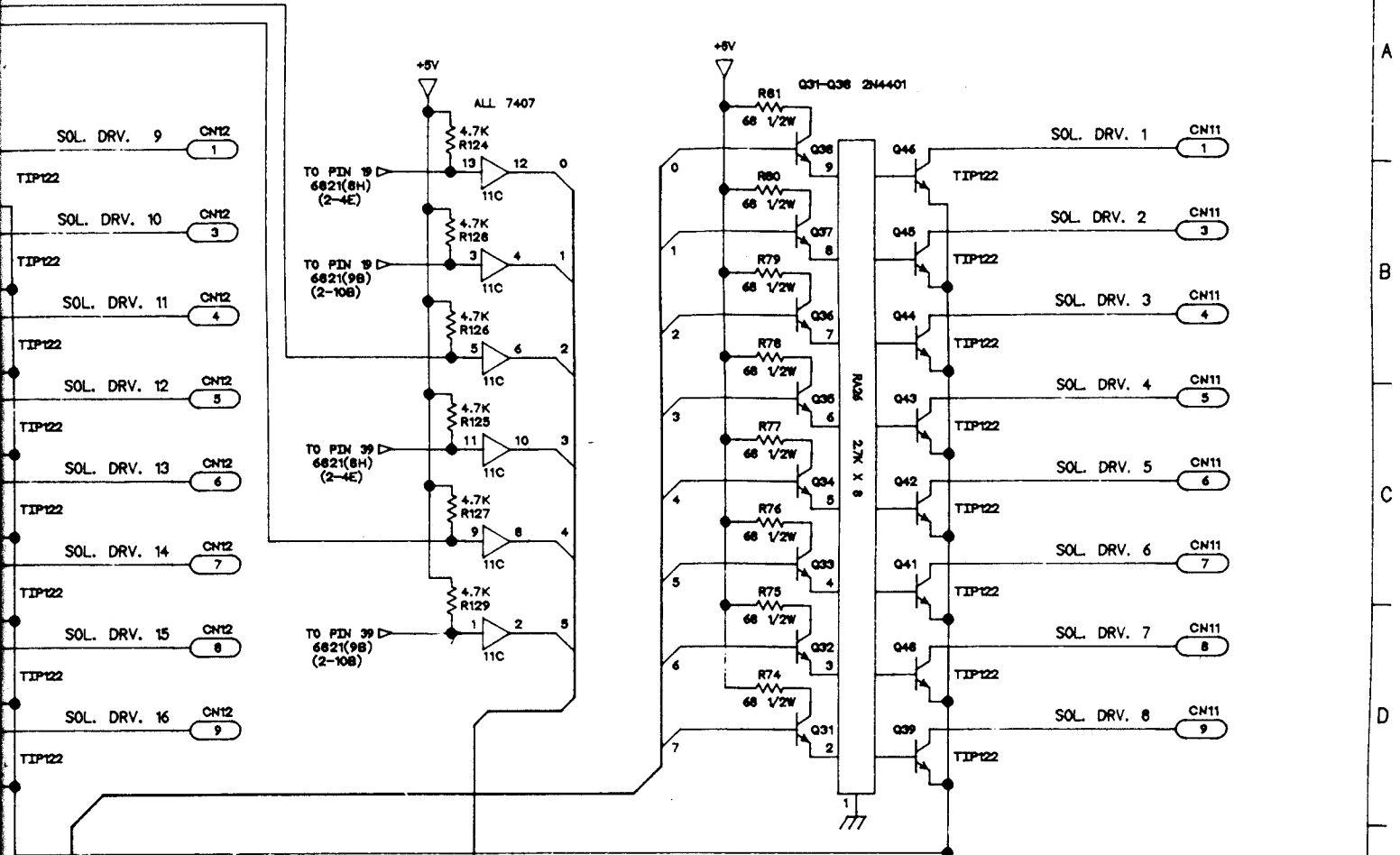

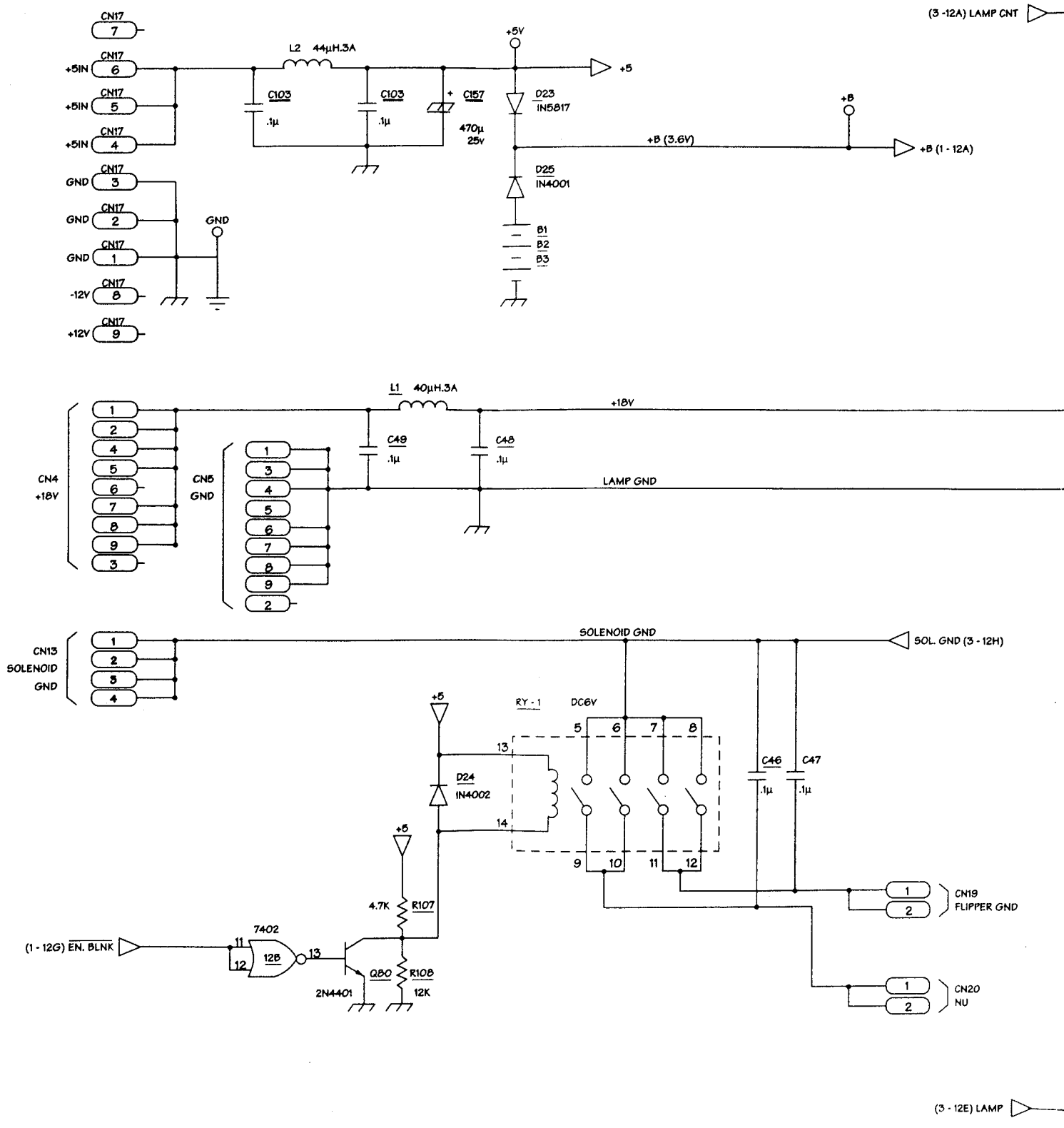

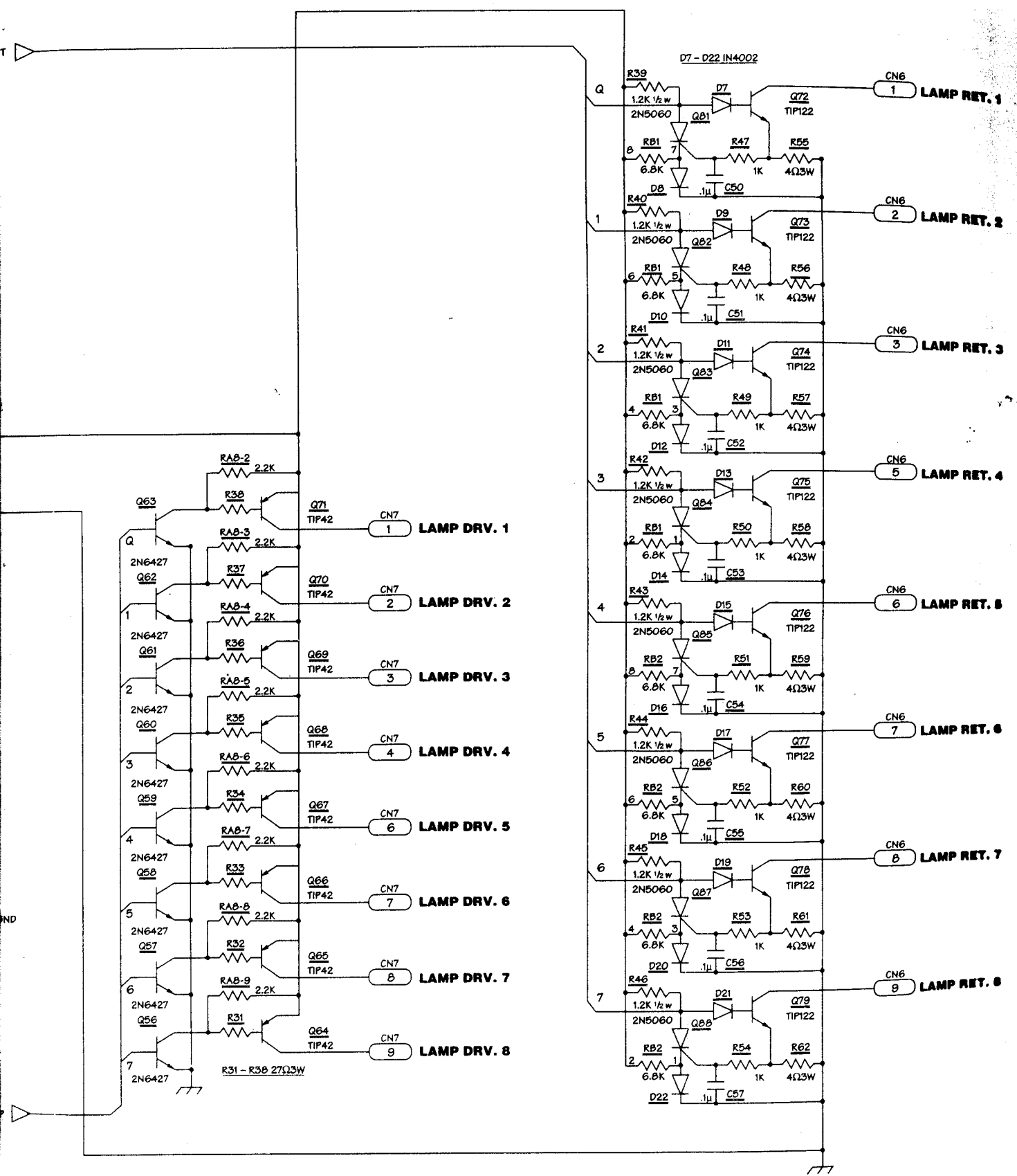

A
B
C
D
E
F
G
H

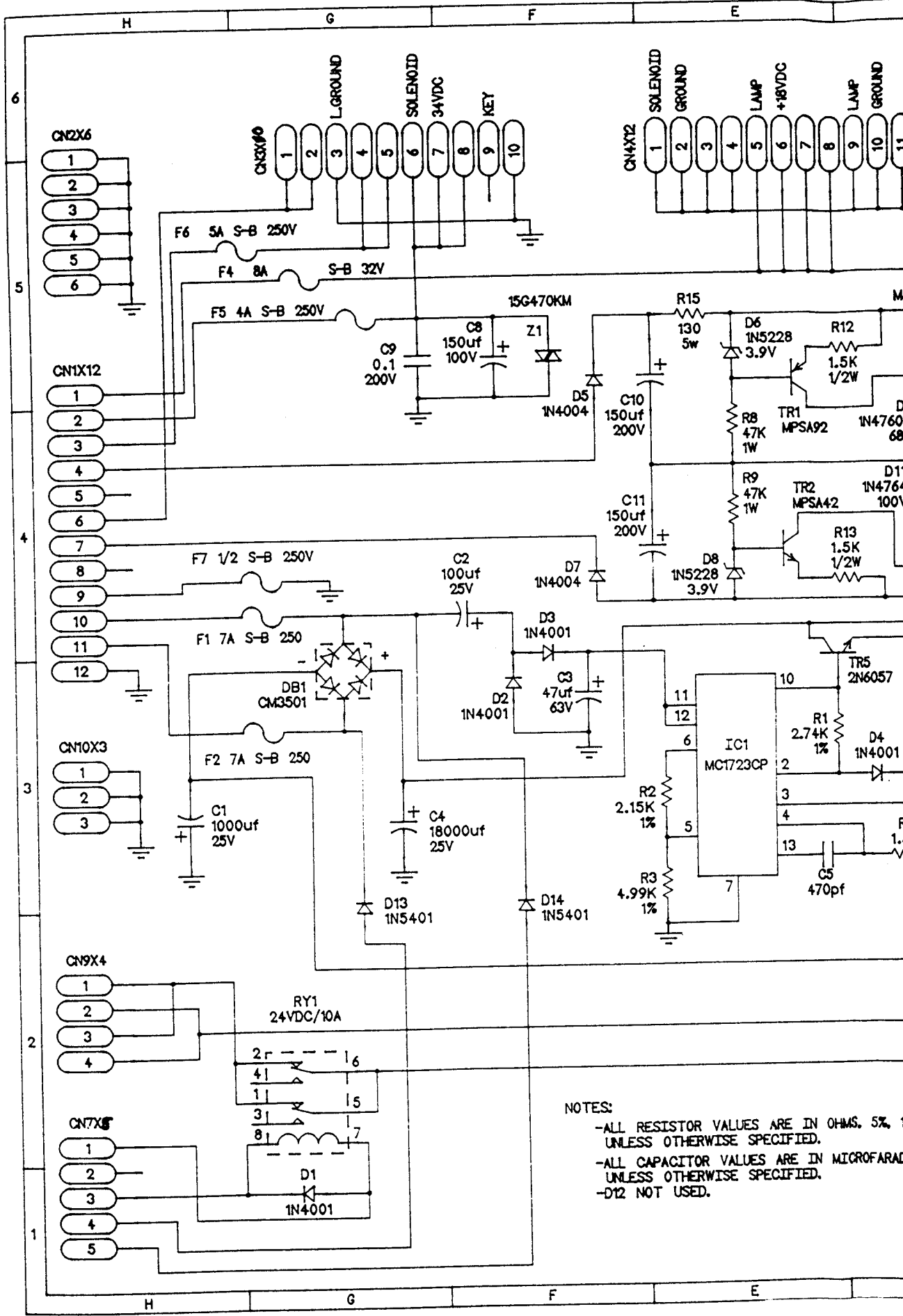

NOTES:

- ALL RESISTOR VALUES ARE IN OHMS. 5% UNLESS OTHERWISE SPECIFIED.
- ALL CAPACITOR VALUES ARE IN MICROFARAD UNLESS OTHERWISE SPECIFIED.
- D12 NOT USED.

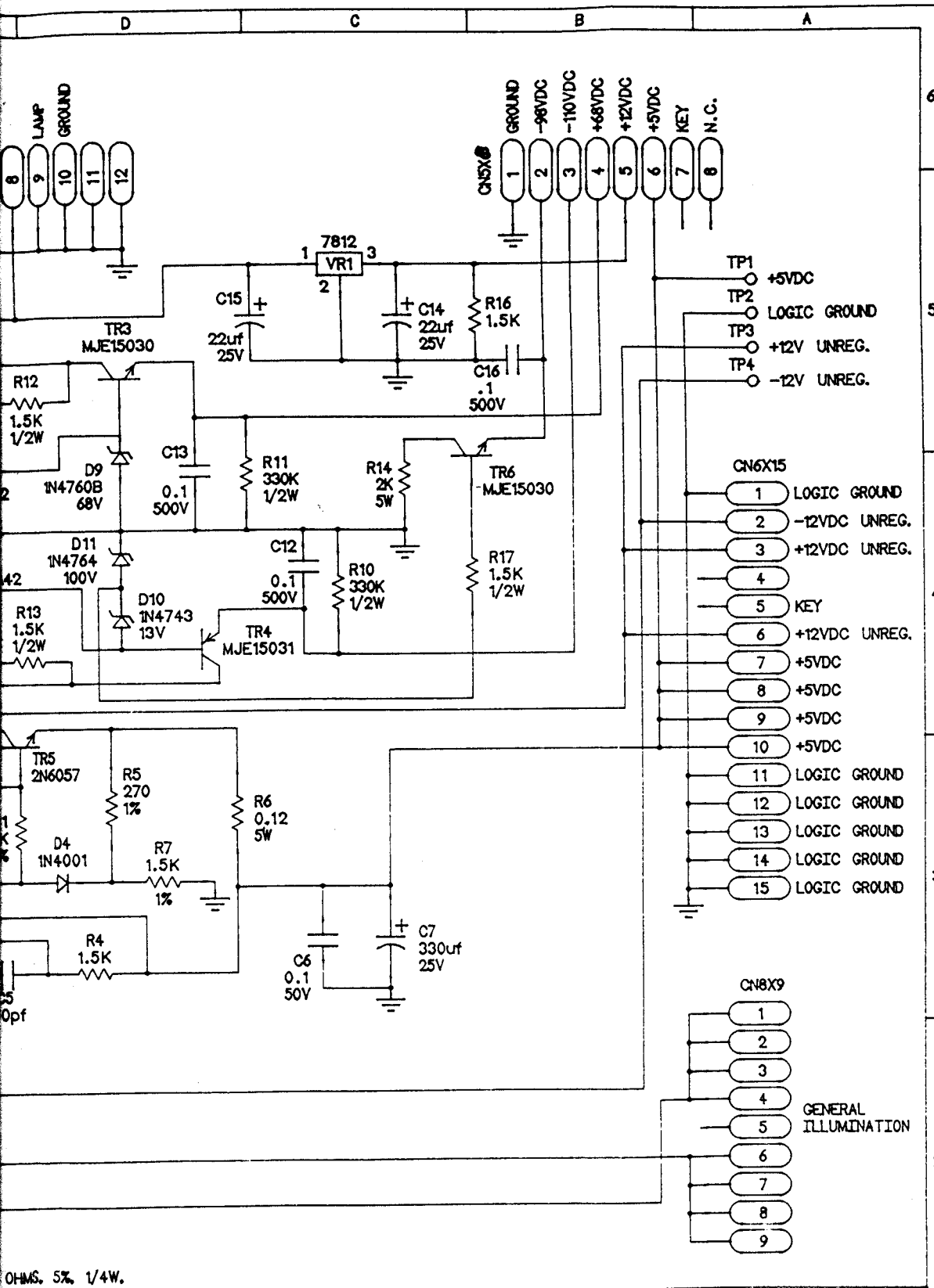

OHMS. 5% 1/4W.
MICROFARADS.

DATA EAST PINBALL
POWER SUPPLY BOARD SCHEMATIC

D	C	B	A	PREPARED BY: CES INC.	DWG C	PART NO. 520-5047-02	REV A
				SIZE SHEET 1 OF 1	MODEL		

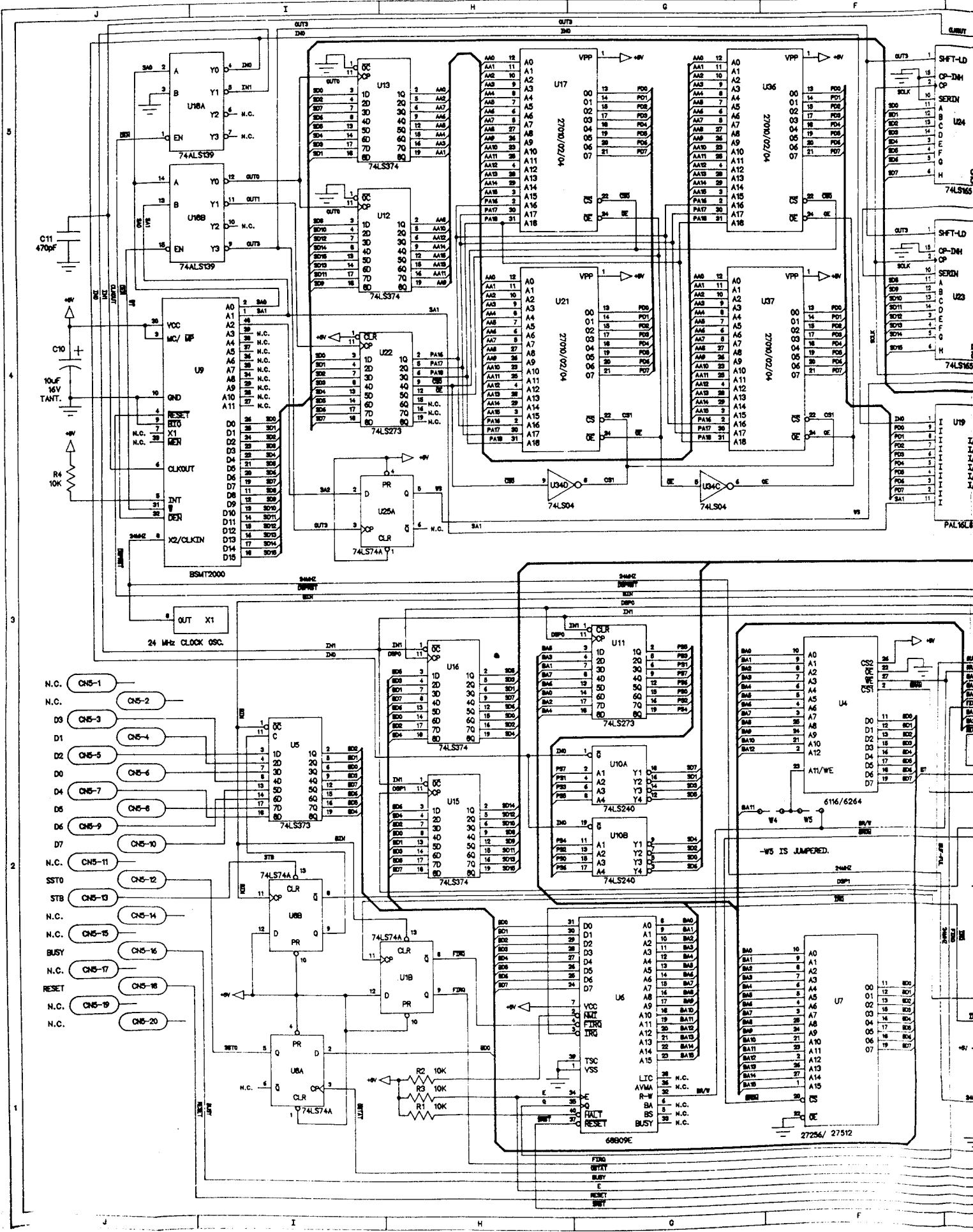

74 Sound Board (520-5077-00) Schematic

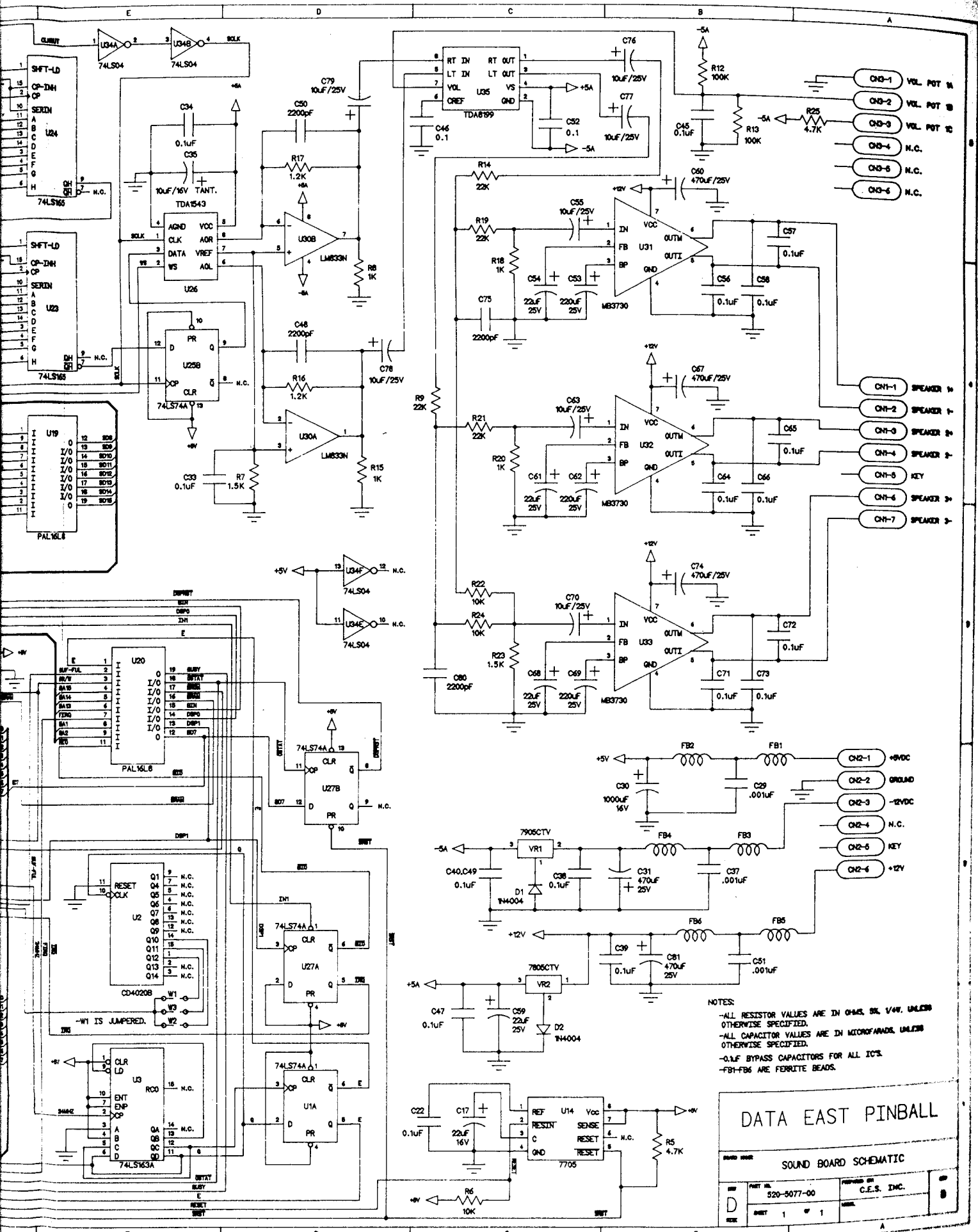

NOTES:
 -ALL RESISTOR VALUES ARE IN OHMS, OR 1/4W, UNLESS OTHERWISE SPECIFIED.
 -ALL CAPACITOR VALUES ARE IN MICROFARADS, UNLESS OTHERWISE SPECIFIED.
 -0.1UF BYPASS CAPACITORS FOR ALL IC'S.
 -FB1-FB6 ARE FERRITE BEADS.

DATA EAST PINBALL

SOUND BOARD SCHEMATIC

REV	PART NO. 520-5077-00	PREPARED BY C.E.S. INC.
D	SHEET 1 OF 1	DATE

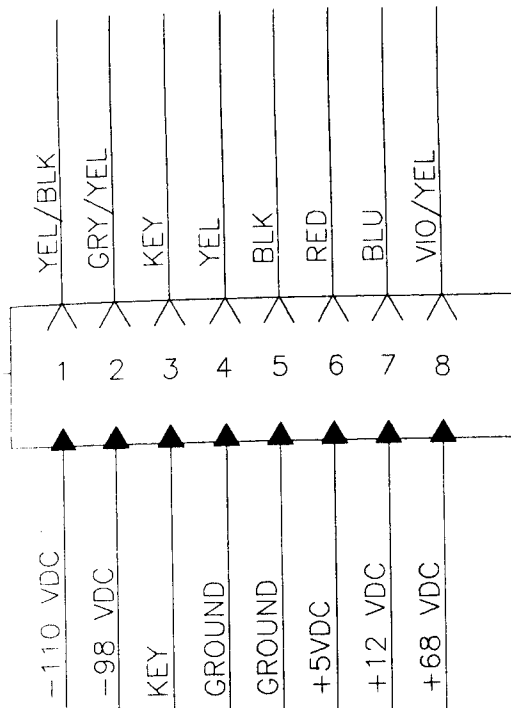

Pi

DOT MATRIX BOARD
520-5052-00

2	0	0	DISPLAY ENABLE	GROUND
1	0	0	ROW DATA	GROUND
	0	0	ROW CLOCK	GROUND
	0	0	COL. LATCH	GROUND
	0	0	PIX CLOCK	GROUND
	0	0	SER. DATA	GROUND
	0	0	NOT USED	NOT USED.

RIBBON CABLE
P2

2	0	0	DISPLAY ENABLE	GROUND
1	0	0	ROW DATA	GROUND
	0	0	ROW CLOCK	GROUND
	0	0	COL. LATCH	GROUND
	0	0	PIX CLOCK	GROUND

RIBBON CABLE
CNI

0	0	COL. LATCH	GROUND
0	0	PIX. CLOCK	GROUND
0	0	SER. DATA	GROUND
0	0	NOT USED	NOT USED

14 2
13 1

0	0	NOT USED	NOT USED
0	0	SWITCH 1	SWITCH 2
0	0	SWITCH 3	SWITCH 4
0	0	SWITCH 5	SWITCH 6
0	0	SWITCH 7	SWITCH 8
0	0	DATA 0	DATA 1
0	0	DATA 2	DATA 3
0	0	DATA 4	DATA 5
0	0	DATA 6	DATA 7
0	0	STROBE	RESET
0	0	NOT USED	STAT 0
0	0	STAT 1	STAT 2
0	0	STAT 3	BUSY

26
25

RIBBON CABLE
CN1

RIBBON CABLE
CN3

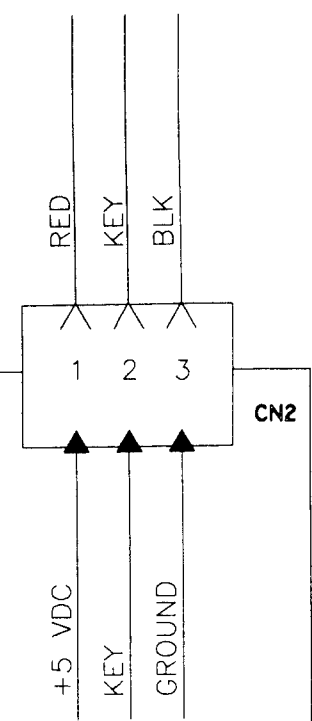

CONTROLLER BOARD
520-5055-00

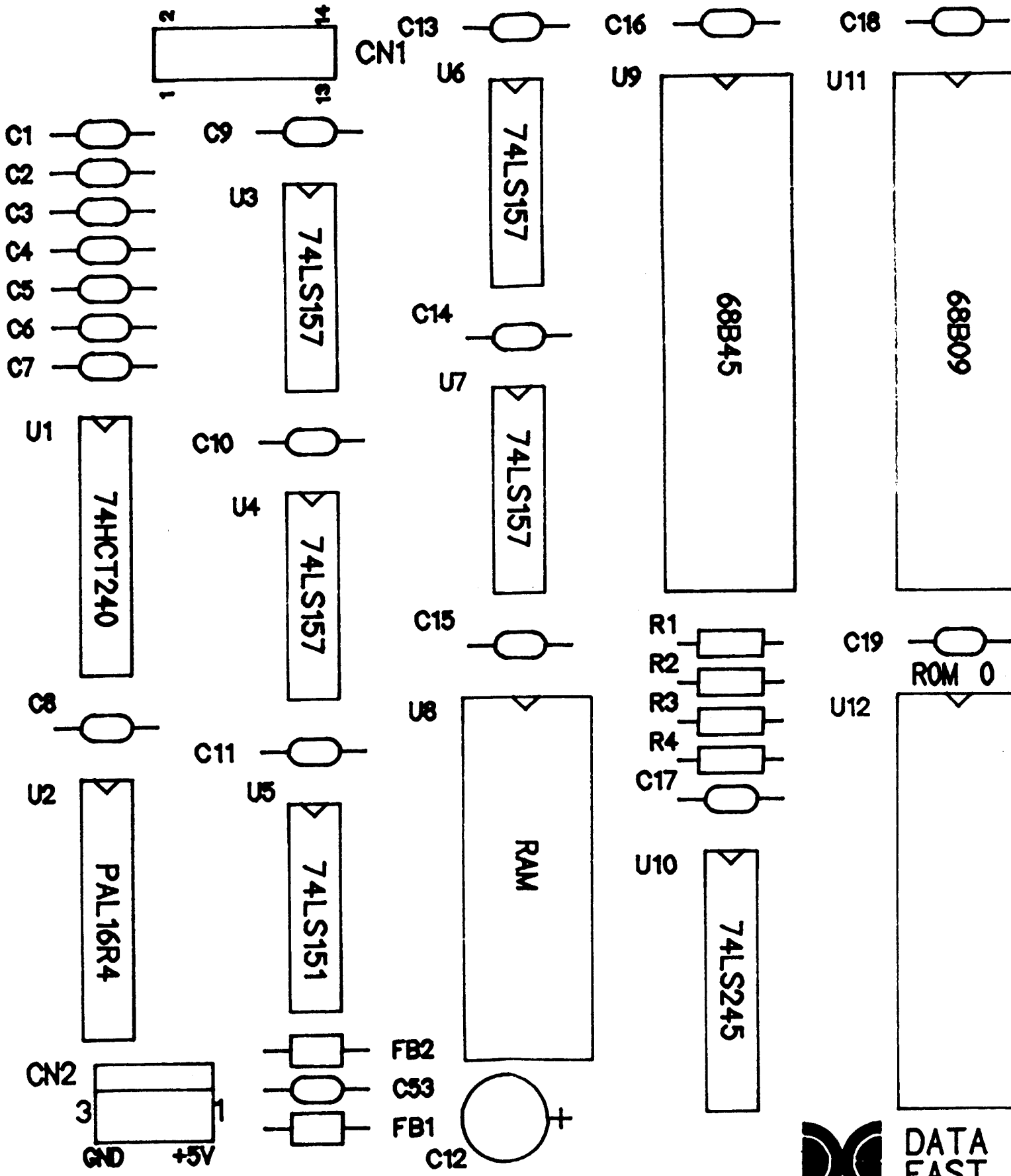

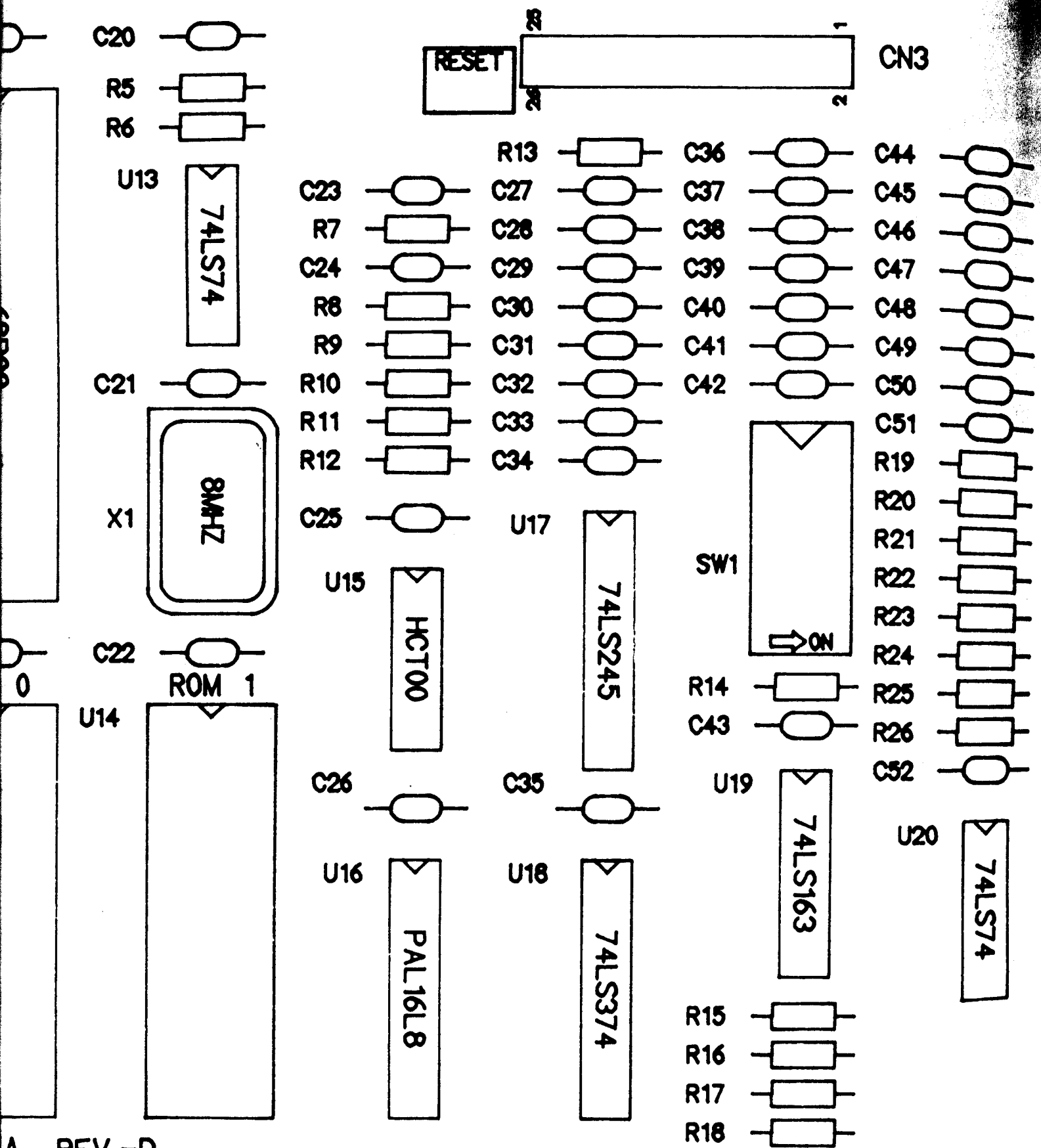

REV.-D
520-5055-00

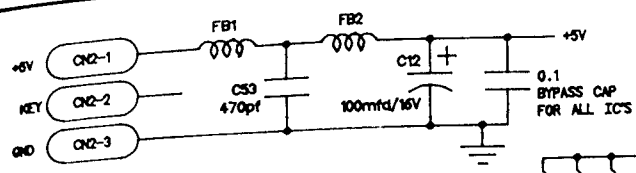

NOTES
 -ALL RESISTOR VALUES ARE IN OHMS, 1/4W, 5% UNLESS OTHERWISE SPECIFIED.
 -ALL CAPACITOR VALUES ARE IN MICROFARADS, UNLESS OTHERWISE SPECIFIED.
 -FB1 AND FB2 ARE FERRITE BEADS.

R19-R26 = 4.7K

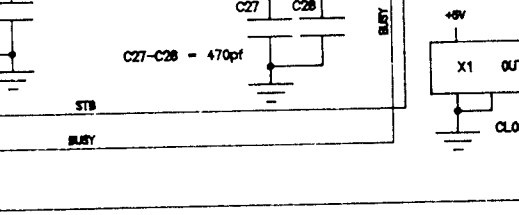
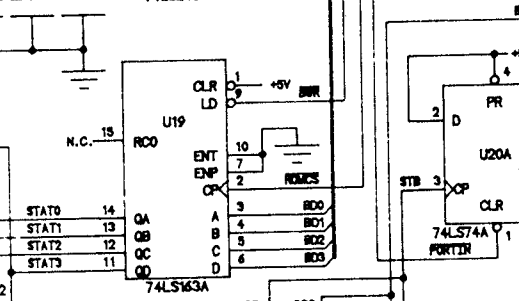
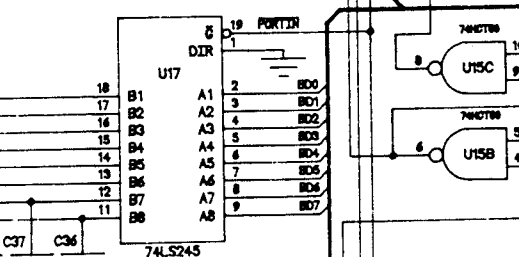
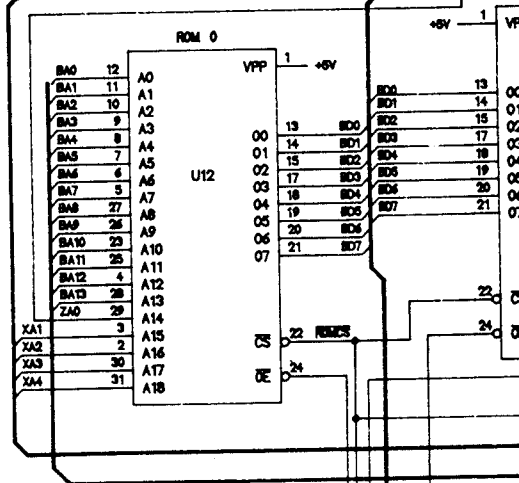
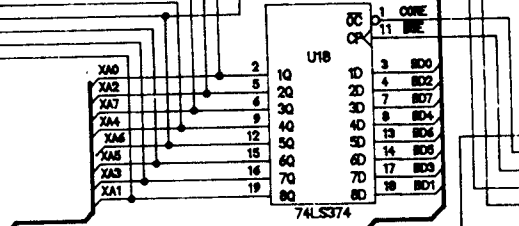
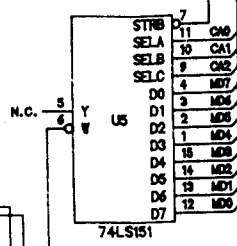
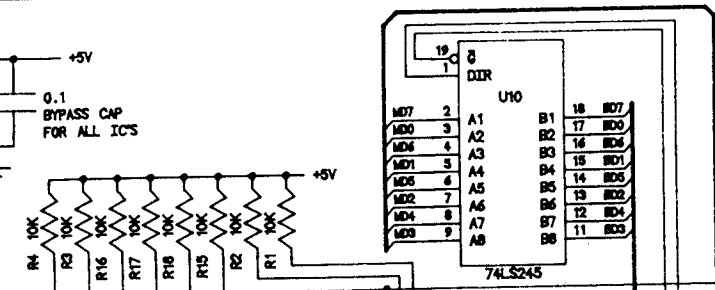
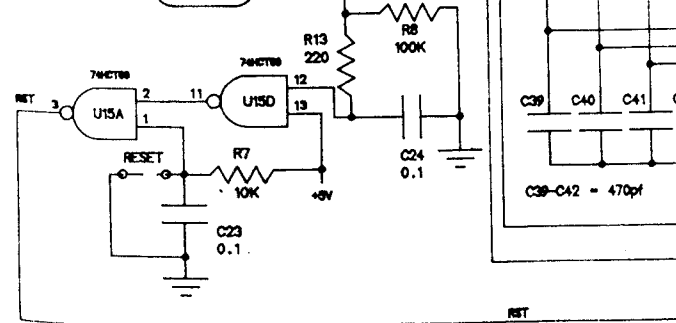
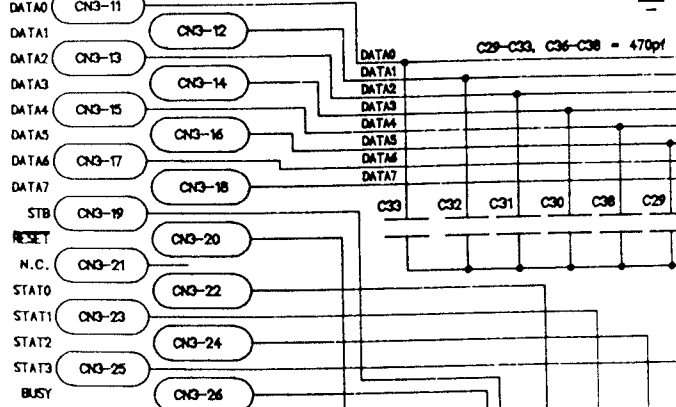
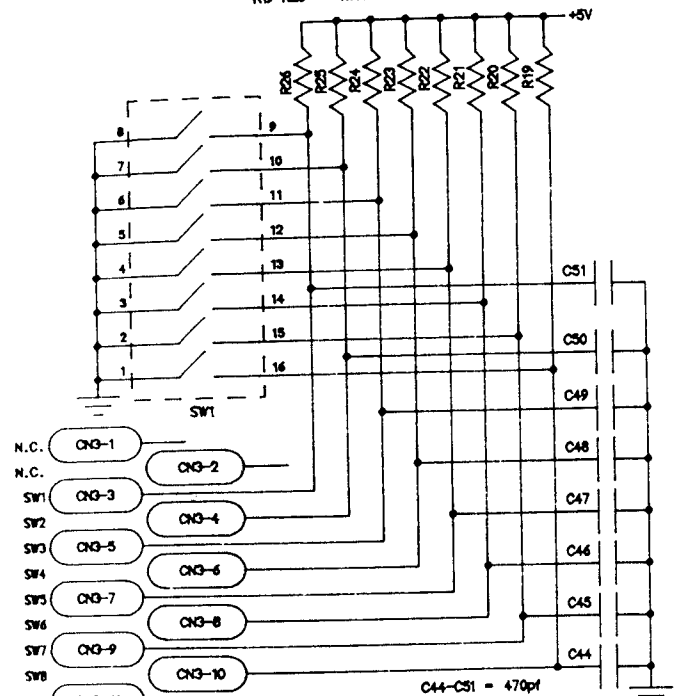

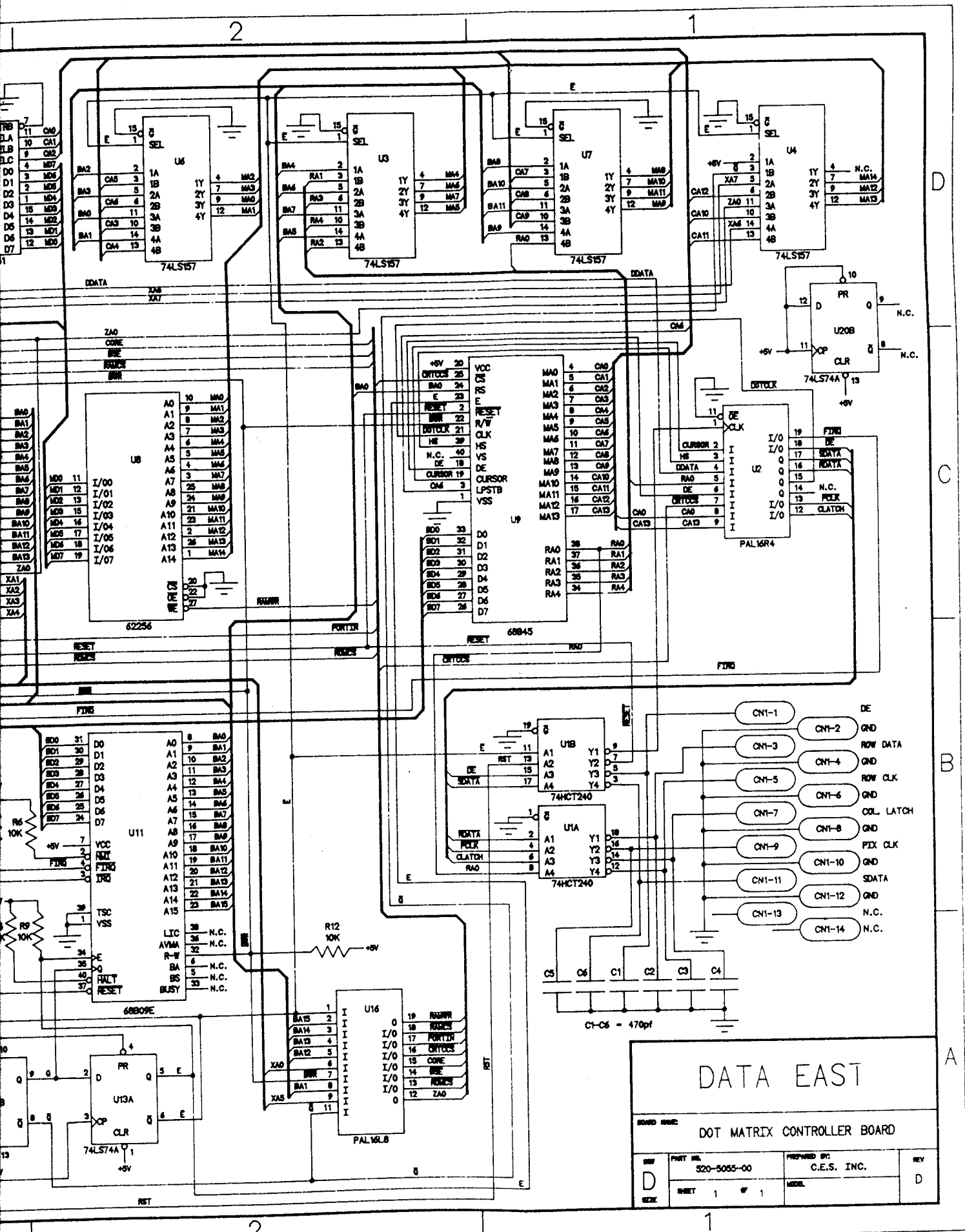

DATA EAST

BOARD NAME: DOT MATRIX CONTROLLER BOARD			
REV	PART NO. 320-5055-00	PREPARED BY: C.E.S. INC.	REV
D	SHEET 1 OF 1	MODEL	D

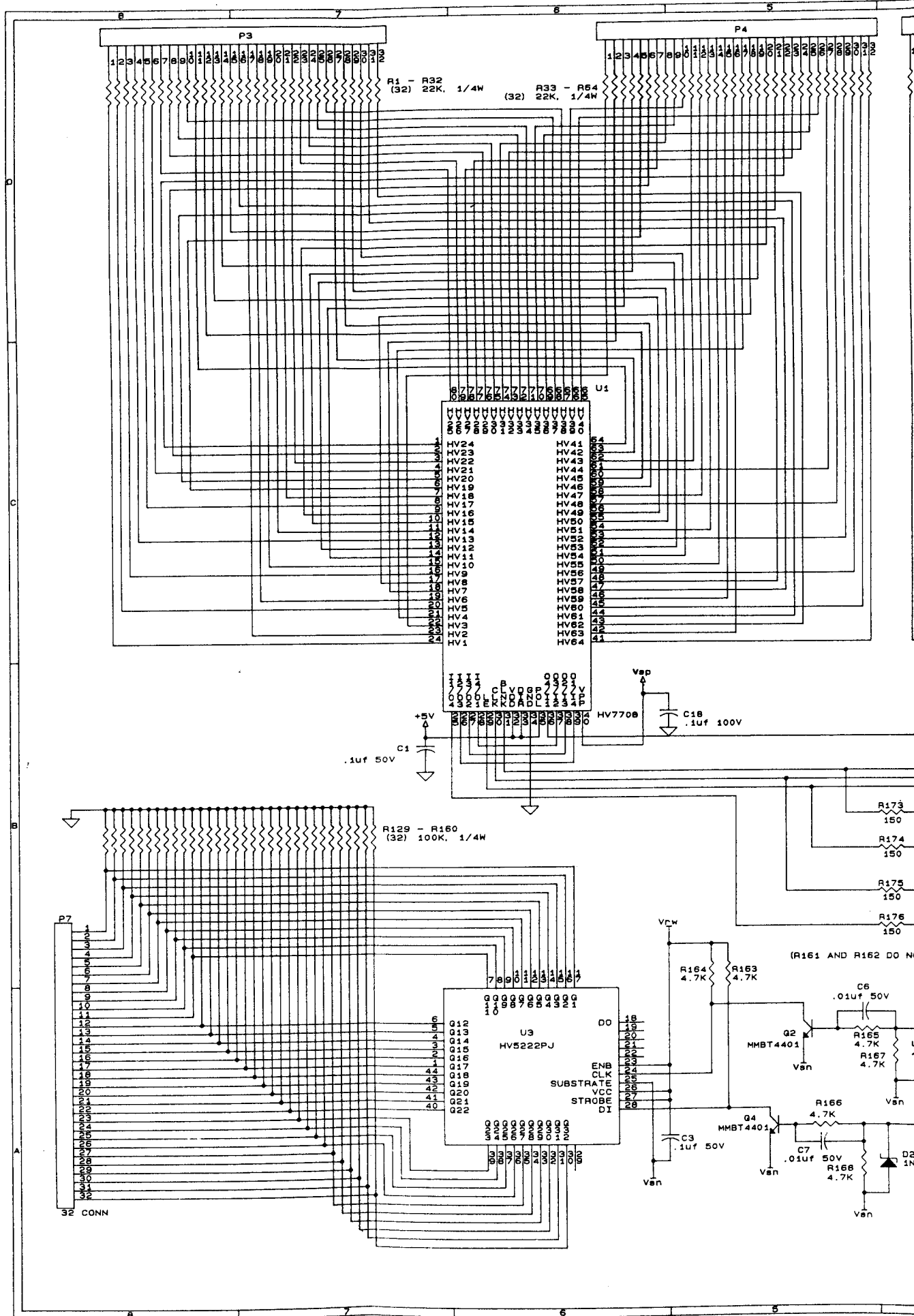

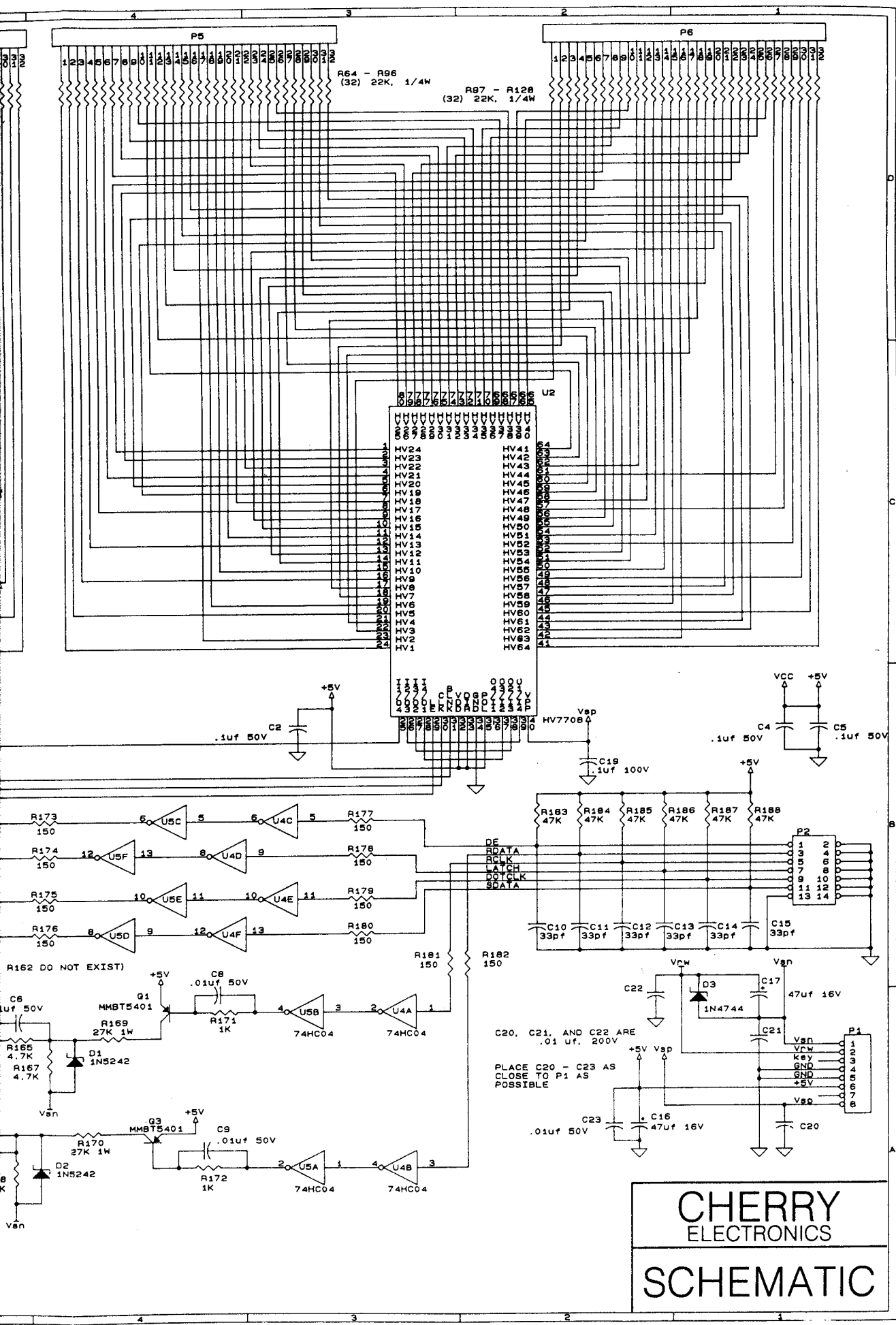

CHERRY
ELECTRONICS
SCHEMATIC

DISPLAY GP-4

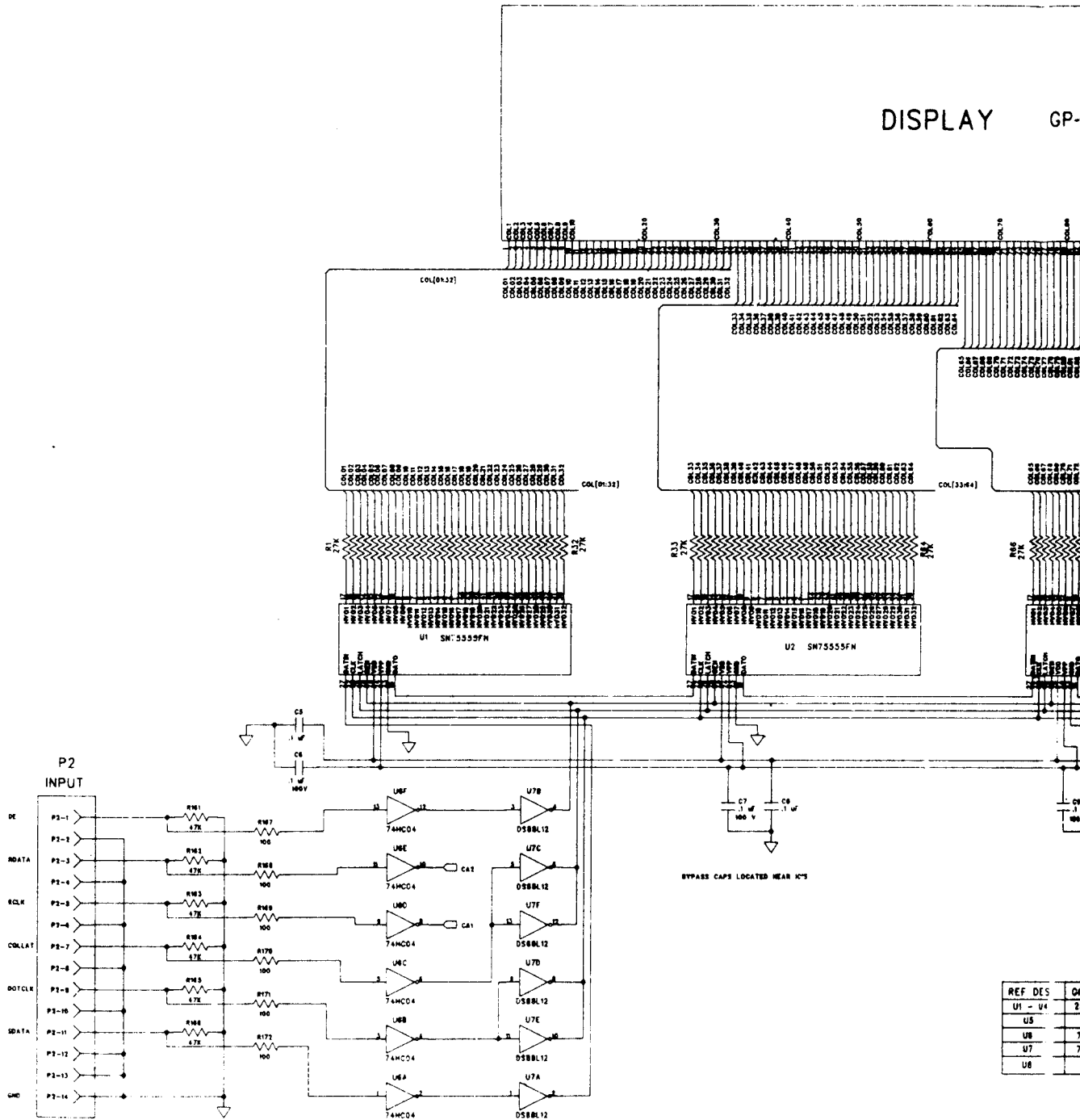

REF	DES	QTY
U1 - U4		23
U5		7
U6		7
U7		7
U8		7

2. RESISTOR VALUES ARE IN OHMS, 1/8 WATT, 5%.
1. CAPACITOR VOLTAGES ARE 50V, 20%.
- NOTES: UNLESS OTHERWISE SPECIFIED.

GP-032X128-01

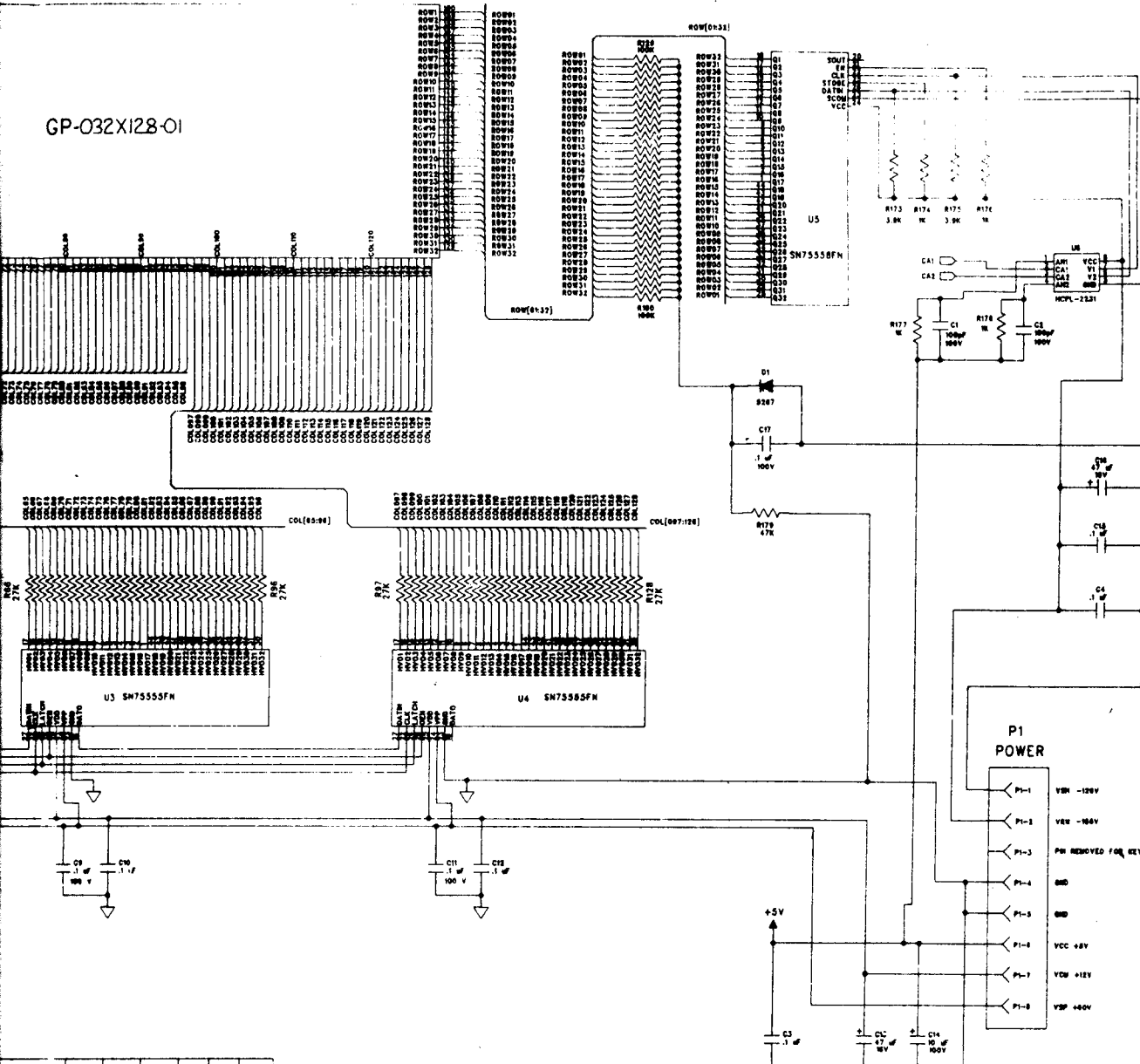

REF DES	QND	VCC	VRW	VSN	VCM	VSP
U1 - U4	23			23	24	
U5			24	23		
U6	7	14			14	
U7	7					
U8			8	5		

PADS LOGIC VER. 2.03 FILE: DM32128.SCH		UNLESS OTHERWISE SPECIFIED DIMENSIONS ARE IN INCHES. TOLERANCES: XX ± .005 XX ± .020 ANGLES ±		CONTR NO.		BABCOCK DISPLAY PRODUCTS, INC. 1051 S. EAST STREET ANAHEIM, CALIFORNIA 92805			
		MATERIAL		DRAWN BY RAY DEESE CHECK BY				DATE 10/6/91 DATE	
				APPR BY		DATE			
				DO NOT SCALE PRINT				SCHEMATIC	
NEXT ASSY USED ON		APPLICATION		CODE IDENT		REV			
GP-032X128-01				66846 1510-0106		A			
				SCALE		SIZE D SHEET 1 OF 1			

PART NO.	INTL CODE
281103-01	S

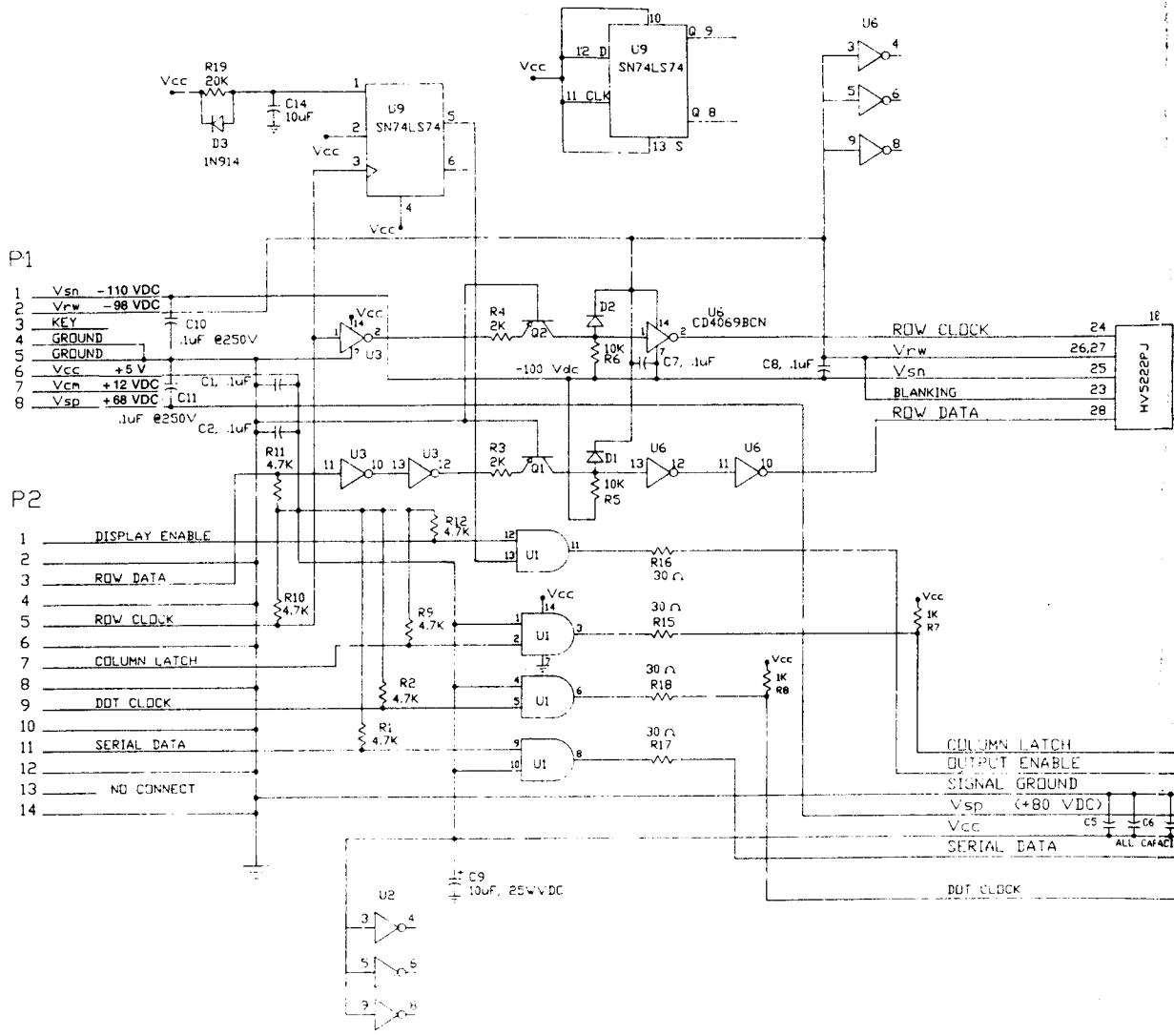

NOTES

REVISIONS				
ZDNE	SYM	DESCRIPTION	DATE	APPROVED

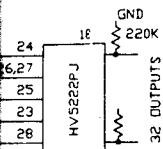

CATHODE CONNECTIONS

DALE PLASMA DISPLAY
PD-128G032

ANODE CONNECTIONS

ANODE CONNECTIONS

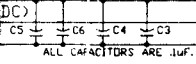
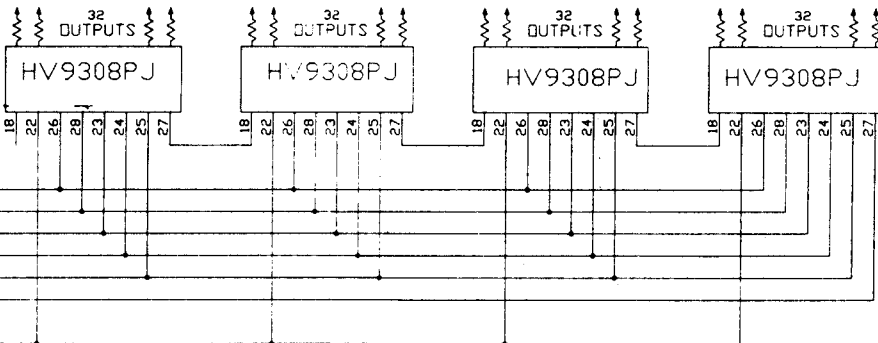

281103

FIG. D
B

CLASS 2

<small>THIS DRAWING AND SPECIFICATIONS ARE THE PROPERTY OF DALE ELECTRONICS, INC. AND ARE TO BE USED IN STRICT CONFIDENCE AND SHALL NOT BE REPRODUCED OR COPIED OR USED AS THE BASIS FOR THE MANUFACTURE OR SALE OF APPARATUS WITHOUT PERMISSION.</small> <small>WEAR SHARP EDGES AND CORNERS</small> <small>UNITS APPLY OVER NON-PAINTED FINISHES</small> <small>COMMERCIAL TOLERANCES APPLY TO STOCK ITEMS</small> <small>GEOMETRIC SYMBOLS PER ANSI Y14.5</small> <small>ALL MACHINE SURFACES</small> <small>DIMENSIONS IN BRACKETS OR ARE IN MILLIMETERS UNLESS OTHERWISE SPECIFIED</small>	<small>UNLESS OTHERWISE SPECIFIED</small> <small>DIMENSIONS ARE IN INCHES</small> <small>TOLERANCES ON FRACTIONS DECIMALS ANGLES</small> <small>11/64 .005 .030</small> <small>XXXX 1.000</small>	<small>METRIC</small> <small>(ALL METERS)</small> <small>DECIMALS ANGLES</small> <small>XXXXX .001</small>	SIGNATURES DR <i>David Antyka</i> 92-12-21 CHKD <i>Zora Rydzman</i> 92-03-06 DSGN <i>Z. SHANKS</i> 92-02-06 DR FILED DESK SEXT SUPV APPD <i>(K. R. RAY)</i> 92-03-07	DATE 92-12-21 92-03-06 92-02-06 92-03-07	DALE ELECTRONICS, INC. A COMPANY OF VISHAY COLUMBUS, NEBRASKA
	MATERIAL			TITLE ELECTRICAL SCHEMATIC	
	FINISH			APD-128G032	SIZE CODE IDENT NO. DRAWING NO. D 91637 281103
				SCALE NONE	SHEET 1 OF 1

Solid State Flippers PCB Wiring Diagram

Connector CN 1

Pin#	Goes to...	Wire Color	It Is...
1	Right Flipper EOS	BRN-VIO	Right Flipper End of Stroke
2			Key
3	CPU CN 10-1	WHT-GRY	Switch Ret. 8
4	CPU CN 8-9	GRN-GRY	Switch Drive 8
5	CPU CN 10-2	WHT-VIO	Switch Ret. 7
6	Right Flipper Switch	BLU-VIO	Right Flipper Enable
7	CPU CN 5-9	BLK	GND
8	PS CN 6-10	GRY-WHT	+ 5V DC
9	Left Flipper EOS	BRN-GRY	Left Flipper End of Stroke
10			
11	Left Flipper Switch	BLU-GRY	Left Flipper Enable
12	Upper Right Flipper Switch	GRY-VIO	Upper Right Flipper Enable

Connector CN 2

Pin #	Goes To...	Wire Color	It Is...
1	Upper Right Flipper Coil	BLK-YEL	Upper Right Flipper Power
2	Upper Right Flipper Coil	BLK-YEL	Upper Right Flipper Power
3			Not Used
4	Left Flipper Coil	GRY-YEL	Left Flipper Power
5	Left Flipper Coil	GRY-YEL	Left Flipper Power
6			Key
7	Right Flipper Coil	BLU-YEL	Right Flipper Power
8	Right Flipper Coil	BLU-YEL	Right Flipper Power
9	PS CN 1-11	GRY	9V AC
10	PS CN 1-10	GRY-GRN	9V AC
11	PPB J7-1	BLK-WHT	50V DC

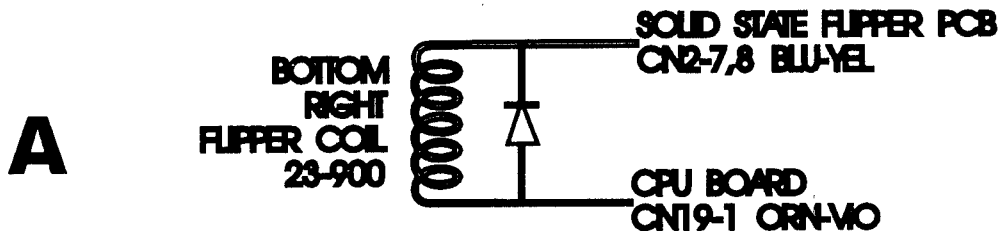
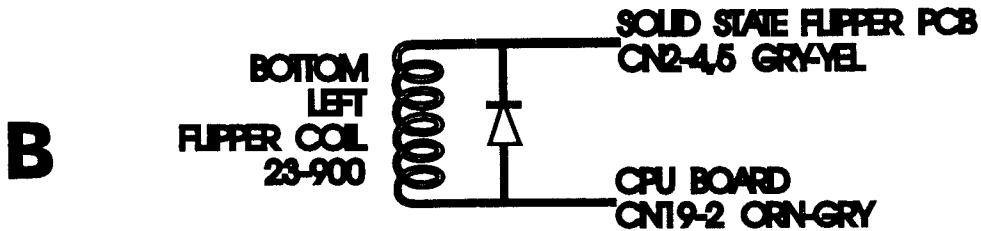
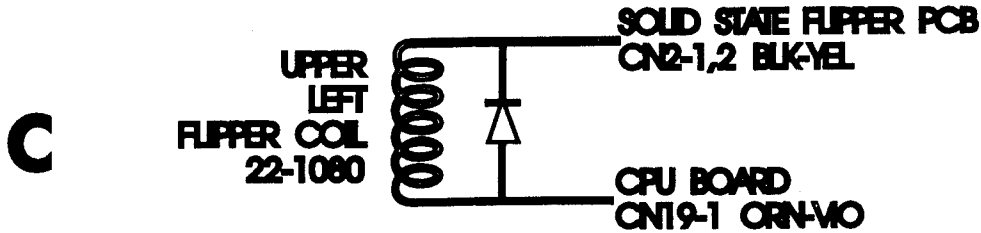

		CN1		CN2			
Upper Flip. Switch	GRY-VIO	1 2	Upper Flipper Enable	Upper Flipper Power	0 1	BLK-YEL	Upper Flipper Coil
Left Flipper Switch	BLU-GRY	1 1	Left Flipper Enable	Upper Flipper Power	0 2	BLK-YEL	Upper Flipper Coil
Not Used		1 0	Not Used	Not Used	0 3		Not Used
Left Flipper EOS	BRN-GRY	0 9	Left Flipper EOS	Left Flipper Power	0 4	GRY-YEL	Left Flipper Coil
PS CN6-10	GRY-WHT	0 8	+5v DC	Left Flipper Power	0 5	GRY-YEL	Left Flipper Coil
Right Flipper Switch	BLU-VIO	0 7	Right Flipper Enable	KEY	0 6	KEY	
CPU CN5-7	BLK	0 6	Ground (GND)	Right Flipper Power	0 7	BLU-YEL	Right Flipper Coil
CPU CN10-2	WHT-VIO	0 5	Switch Return 7	Right Flipper Power	0 8	BLU-YEL	Right Flipper Coil
CPU CN8-9	GRN-GRY	0 4	Switch Drive 8	+8v AC	0 9	GRY	PS CN1-11
CPU CN10-1	WHT-GRY	0 3	Switch Return 8	+8v AC	1 0	GRY-GRN	PS CN1-10
	KEY	0 2	KEY	+50v DC	1 1	BLK-WHT	PPB J7-1
Right Flipper EOS	BRN-VIO	0 1	Right Flipper EOS	+50v DC	1 2	BLK-WHT	PPB J7-5

SOLID STATE 3 FLIPPER PCB
520-5033-03

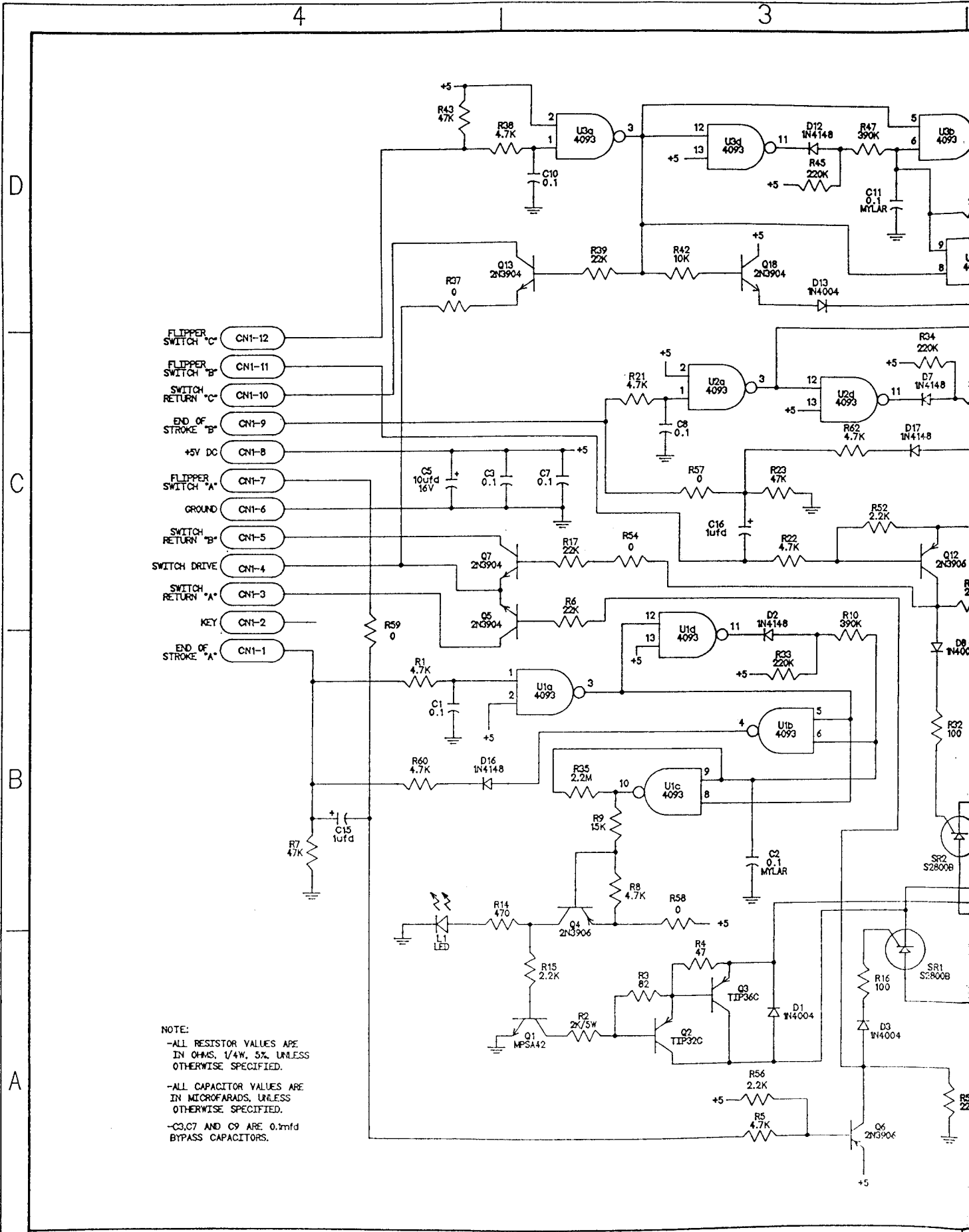

NOTE:
 -ALL RESISTOR VALUES ARE IN OHMS, 1/4W, 5%, UNLESS OTHERWISE SPECIFIED.
 -ALL CAPACITOR VALUES ARE IN MICROFARADS, UNLESS OTHERWISE SPECIFIED.
 -C3, C7 AND C9 ARE 0.1mfd BYPASS CAPACITORS.

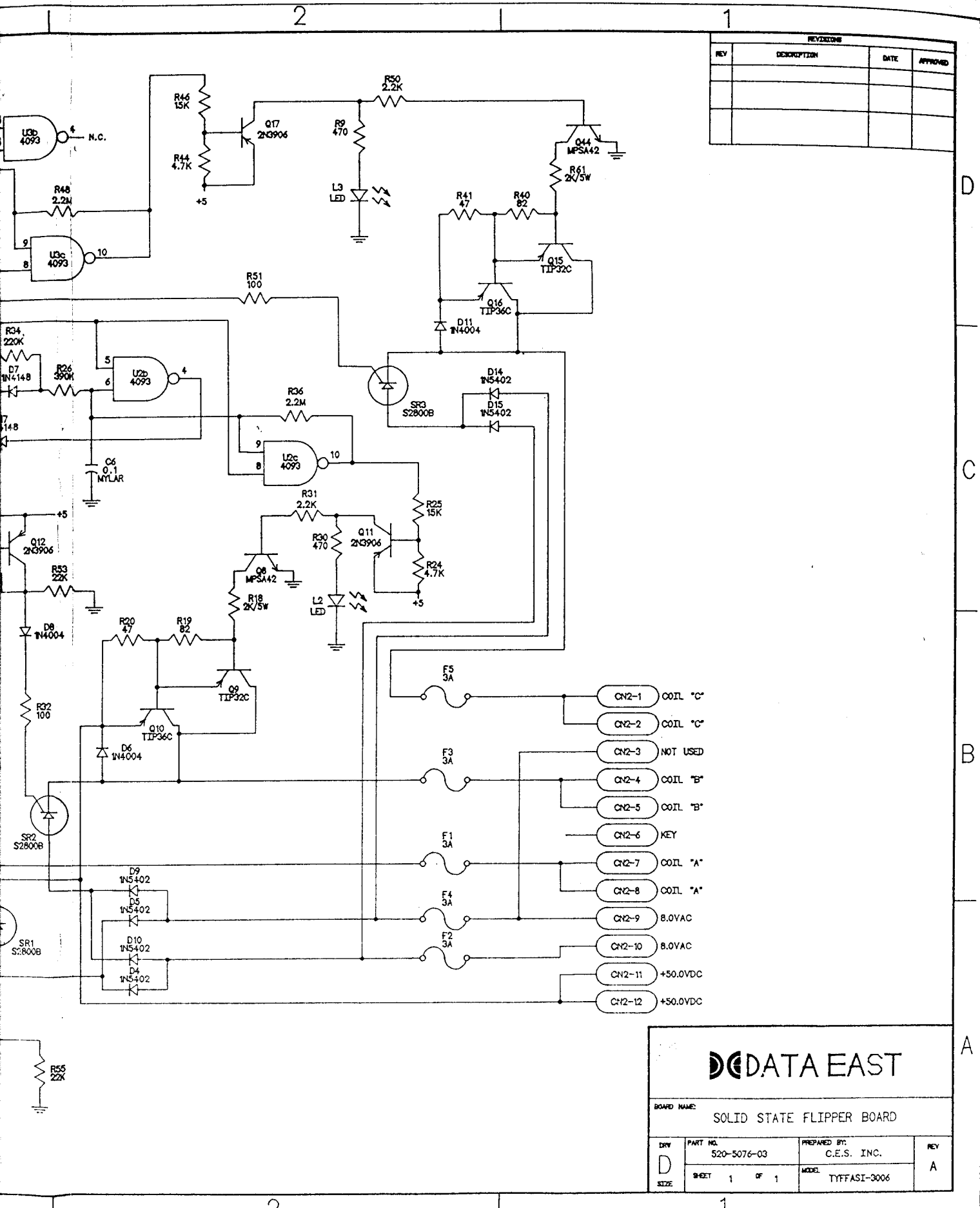

REVISIONS			
REV	DESCRIPTION	DATE	APPROVED

DATA EAST

BOARD NAME: SOLID STATE FLIPPER BOARD

DRY	PART NO. 520-5076-03	PREPARED BY: C.E.S. INC.	REV A
SIZE	SHEET 1 OF 1	MODEL TYFFASI-3006	

Solid State Flipper Switch Wiring Diagram

(Fig 1)

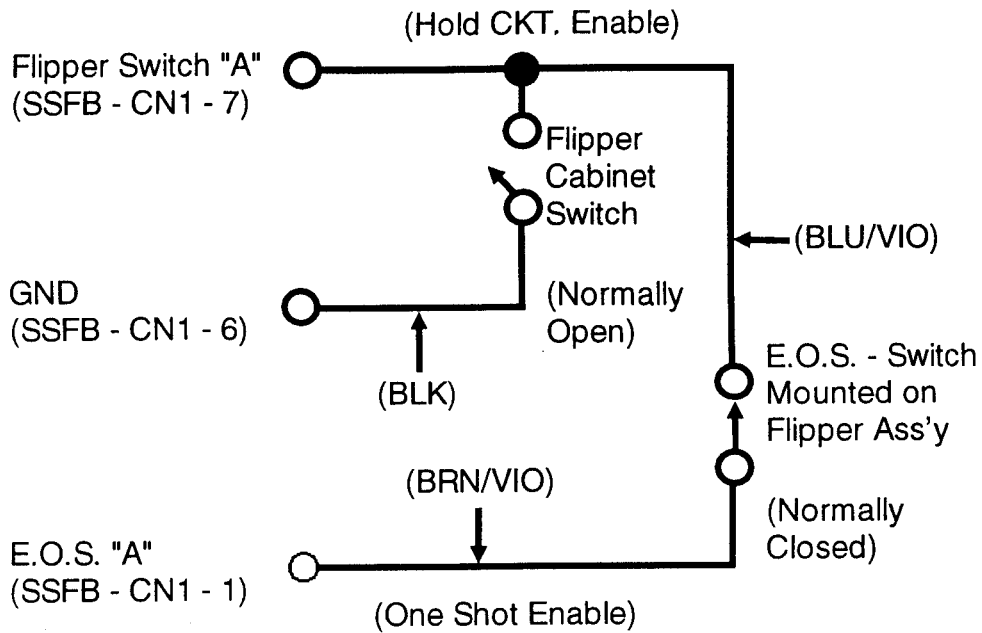

New Solid State Flipper Board

We have redesigned our Solid State Flipper Board (S.S.F.B.) so that a misadjustment or failure of the End-of-Stroke (E.O.S.) Switch will not affect the operation of the flippers. The flippers will still work! The E.O.S. switch is strictly an added feature, not a functional part of the circuit (see E.O.S. Theory of Operation).

Theory of Operation for the Solid State Flippers

The Solid State Flipper Board is a Multiple Flipper Solenoid Driver Circuit. Each solenoid driver circuit contains a One Shot Timer, a 50V Driver, and an 8V Driver.

Looking at one circuit, Schmidt NAND gates U1A, U1b, and U1D make up the One Shot Timer. The timer length is controlled by R10, R33 and C2. The output of the timer is gated at U1C with the buffered switch input from Q6. The output of U1C controls the 50V driver circuit consisting of Q4, Q1, Q2, Q3, and D1. As long as the flipper button is activated, Q6 will keep the 8V driver circuit, SR1, on.

The 50 volts provides the actuation power to the flipper solenoid while the 8 volts provides the holding power.

E.O.S. Switch Theory of Operation

The End of Stroke (E.O.S.) Switch used in our flipper circuit is a Gold Peened Contact, Blade Switch Assembly, mounted on the flipper assembly.

Electrically, it is connected in series with the Cabinet Flipper Switch and the Flipper E.O.S. input on the Solid State Flipper Board (S.S.F.B.) connector CN1 which enables the 50 Volt DC Drive Circuit.

Referring to Fig. 1, one side of the Flipper Cabinet Switch is connected to ground (BLK-Wire), the other side (BLU-VIO Wire) is connected to the flipper switch input on the S.S.F.B. connector CN1 which enables your 9 Volt DC holding voltage and is connected in series to the E.O.S. switch which is a normally closed switch.

The function of the E.O.S. switch is to prevent the flipper bat from being knocked back by a high velocity shot on the playfield. If while holding the flipper in the up position, the bat is moved back 1/16" or more, the E.O.S. switch will close giving the coil another 50 Volt pulse.

E.O.S. Switch Adjustment

The switch contacts should be adjusted so that when the solenoid is energized, the contacts stay closed for almost the full travel of the plunger. The contacts should open 1/16" before the plunger bottoms out or reaches maximum travel.

Troubleshooting Tips

The only indication of a problem you will have is the player complaining that when the flipper bat is being held in the up position, a high velocity shot from one of the playfield solenoids causes the ball to hit the flipper bat and physically knock it back. This will not occur if the E.O.S. is working. Check switch for alignment and continuity, replace if necessary.

Solid State Flipper Circuit Troubleshooting Flowchart

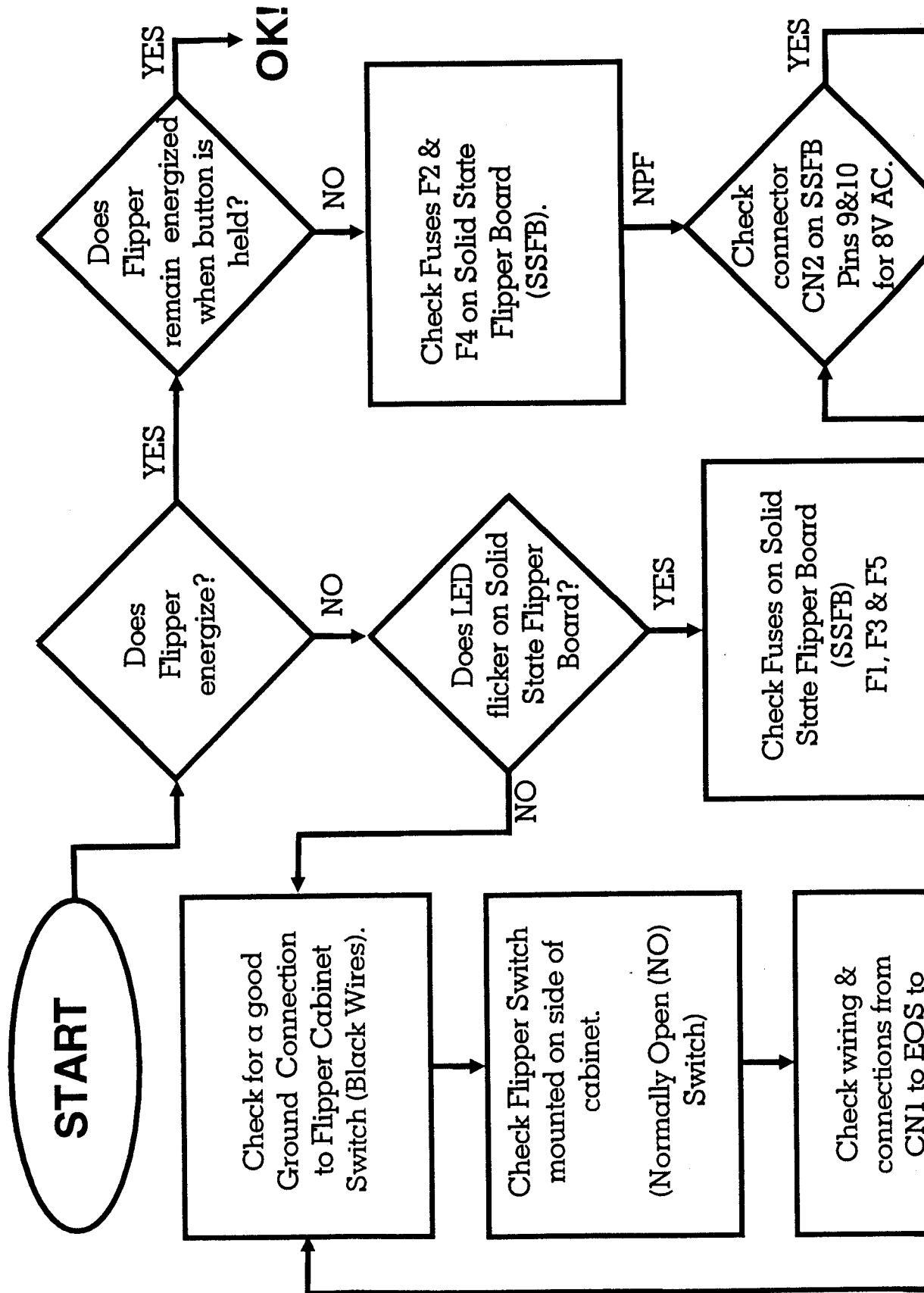

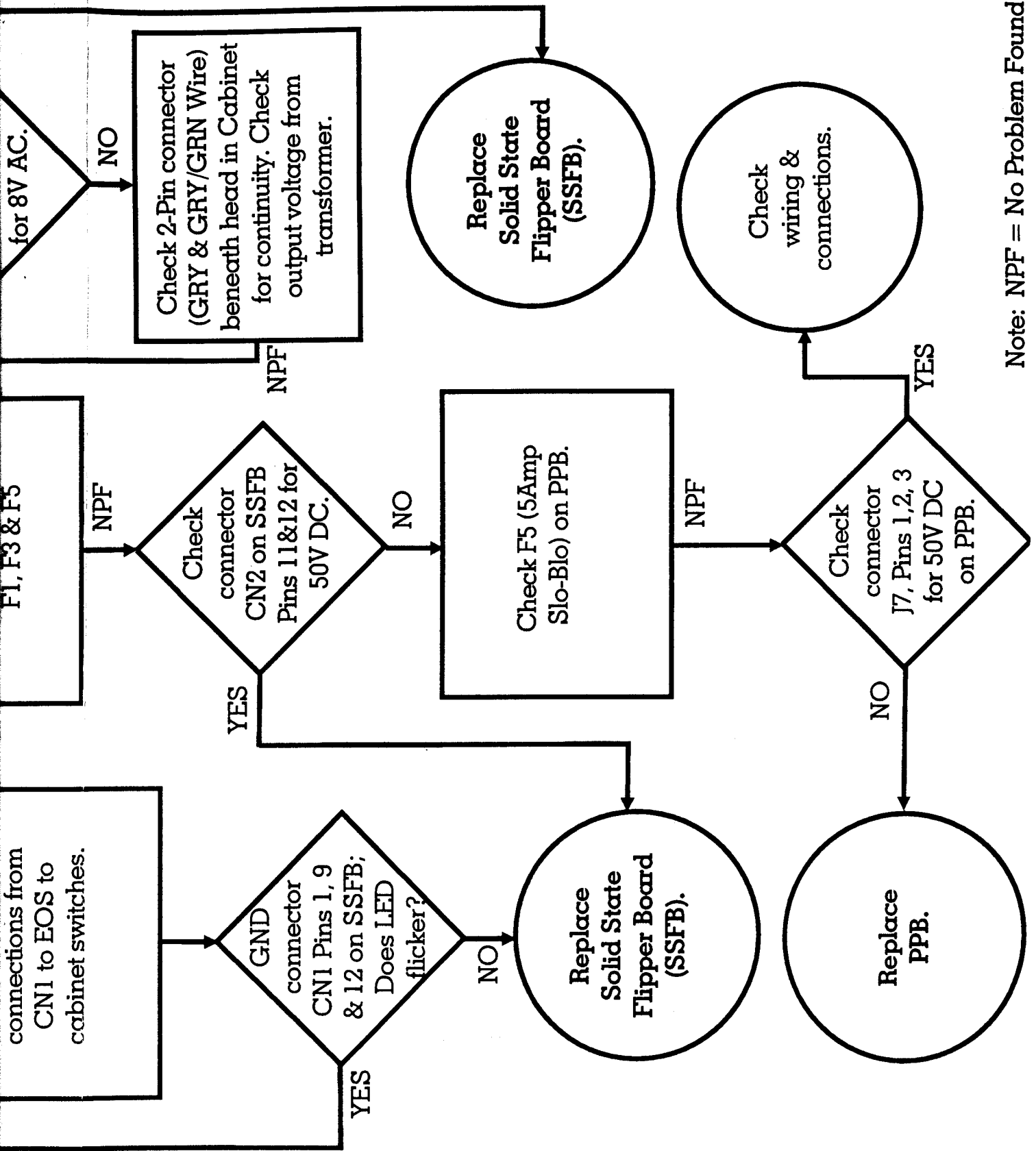

Note: NPF = No Problem Found

PINBALL SERVO CONTROLLER BOARD

THEORY OF OPERATION

The Pinball Servo Controller has been designed to interface between the microprocessor system and the servo operating the "Blinders." The servo used is a conventional radio control model servo and is a mechanical motor drive unit controlled by a servo amplifier that has electro-mechanical feedback positioning. The input signal to these servos is a positive pulse of at least 3.2 volts amplitude and is repeated at 12 to 20 milliseconds intervals. This repetition rate is important to keep the mechanical output resolution smooth, with no "cogging" action, and to provide full torque. The input controlling pulse varies its width to drive the servo output to a required position, and typically varies from 1.0 milliseconds to 2.0 milliseconds for 180 degrees of output rotation by the servo. The operating voltage for full torque is 5.0 volts +/- 0.5 volts, with a current capability of at least 500 milliamps.

CIRCUIT DESCRIPTION

The interface connector is a seven-pin unit and supplies +5 volts, +12 volts, common ground, clock, data and clear/not. It is keyed for correct insertion and has friction lock. The output connector is a three-pin which supplies +5 volt, common ground and a controlling pulse to the servo.

The +5 volt is run directly to the output connector for the servo power, and is filtered by C1 (.01uf) and C3 (100uf). The +12 volt is used to supply VCC to the three ICs, and is regulated by the three terminal voltage regulator U1 (LM78L05). The input side has a filter, C2 (.1uf) and the output side has filters at each IC, being C7, C8 (.01uf) and C4 (100uf).

All three digital control signals are fed to U4, which is a Hex D Flip-Flop (74HC174) and have series resistors, R7, R8 and R9, of 100 ohms, with additional pull-down resistors R10, R11 and R12, of 100K ohm, which form a noise rejection network on the input lines. Only one section of the IC is used, and the other five unused inputs are tied to ground. The DATA OUT is toggled by the input control signals, with the INPUT DATA level being strobed through on a CLOCK transition, and being reset by the CLEAR/NOT signal.

This DATA OUT is now sent to the CONTROL pin of one section of IC3 which is a Quad FET Bi-directional Switch, (CD4066). The input side of this section is tied to VCC, so that when it is enabled by a High, the output side of the switch will also go to VCC. This output drives the remaining three control inputs which are tied together and are also terminated with a pull-down resistor R13 of 10K ohm. This resistor is required because when the output of the first section of the switch is open, the control inputs will "float" and cause intermittent false triggering of their respective sections. All three remaining switches are connected in parallel so that their combined "on" resistance values will be a minimum, and are connected across a timing resistor network R3, R5 and R6.

U2 is a LM555 which is a timer and configured in a "free-running" mode. R4 (91K ohm) sets the cycle time which is nominally 18 milliseconds. The pulse width is determined by C5 (.22uf) and R1, R2, R3, R5 and R6. When the FET Switch is closed, this will short out R3, R5 and R6, leaving R1 (4.3K ohm) and R2 (5K ohm) to set the minimum pulse width by adjusting R2. When the FET Switch opens, it includes R3 (16K ohm), R5 (10K ohm) and R6 (4.7K ohm) in the timing network, and R5 is adjusted for maximum pulse width.

The complete I/O sequence is that when the DATA is strobed in, the output pulse width is MINIMUM, and when the DATA is CLEARED, the output pulse width is MAXIMUM. These are individually set to each required servo output position due to the tolerances in each servo's components.

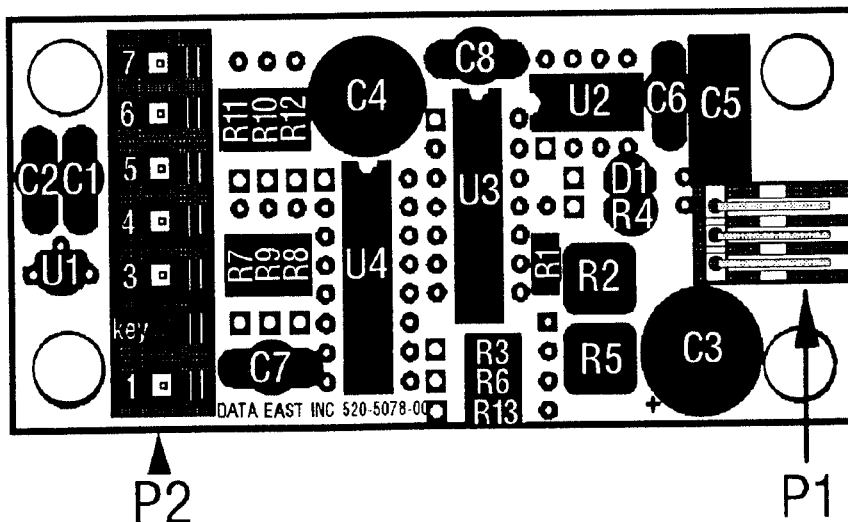

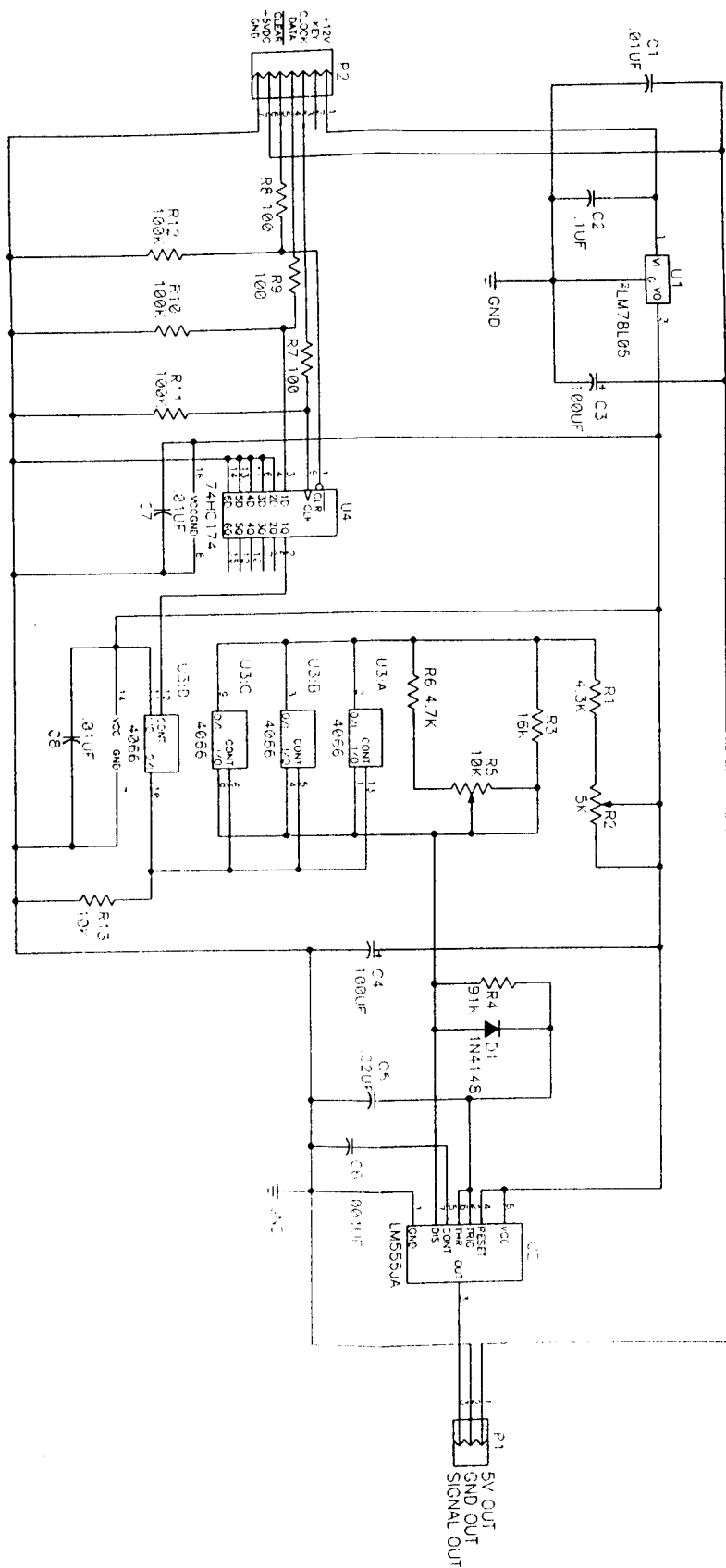

Pinball Servo Controller Adjustment Procedure for Blinders

The Servo Interface (driver) Board has two (2) adjustment control pots. These adjustments are for the closure and opening movements.

Adjustments are necessary when either Servo Interface Board or Motor have to be replaced.

TO REMOVE OLD SERVO MOTOR:

- TURN GAME POWER OFF.
- REMOVE THE BOTTOM ARCH (See Figure 2 for location of the four (4) Bottom Arch Screws).
- DISCONNECT P1 PLUG ON SERVO INTERFACE BOARD TO SERVO MOTOR. (See Figures 4 & 5)
- REMOVE THE THREE (3) BLINDER ASSEMBLY MOUNTING SCREWS FROM THE SERVO MOTOR BRACKET. (See Figure 1)
- REMOVE LINK ARM SET SCREW AND LIFT LINK OFF. (See Figure 3)
- REMOVE THE FOUR (4) SERVO MOTOR MOUNTING SCREWS WITH RUBBER BUSHINGS AND SLIDE MOTOR OUT. (See Figures 1 & 5)

TO INSTALL NEW SERVO MOTOR:

- A. HOLD MOTOR WITH THE SHAFT AND HARNESS POSITIONED TOWARDS YOU. (See Figure 5)
 - B. 'BIAS' THE MOTOR BY TURNING THE SHAFT *CLOCKWISE* (RIGHT) UNTIL IT STOPS. (Fig. 5)
 - C. INSTALL THE FOUR (4) RUBBER MOTOR MOUNT BUSHINGS. (See Figure 5)
 - D. MOUNT MOTOR USING REMOVAL PROCEDURE STEPS IN REVERSE ORDER. (STEPS 1F., 1E., 1D., & 1C.)
- IMPORTANT! USE A NYLON OR NON-METALLIC SCREWDRIVER.**

ADJUST SERVO MOTOR VIA SERVO INTERFACE BOARD-- BLINDER CENTERING (OPEN) ALIGNMENT.

- A. TURN GAME POWER ON.
- B. TURN ON POWER TO TEST. THE BLINDER ASS'Y WILL CYCLE AND OPEN THE BLINDERS, TO A SEMI-OPEN POSITION, ACCORDING TO THE PRESET SERVO INTERFACE BOARD.
- C. REMOVE LINK ARM, MANUALLY FOLD BLINDERS IN (CLOSED). RE-ATTACH THE LINK ARM TO SERVO MOTOR AND BLINDERS. SECURE SCREW. (See Figures 1 & 3)
- D. START DIAGNOSTIC SERVO ARCH TEST.
- E. ONCE IN PLAYFIELD RECHECK ALIGNMENT, USE DIAGNOSTIC ARCH TEST IN THE DIAGNOSTIC PROGRAM. PRESS START AND HOLD BUTTON TO OPEN BLINDER. ENSURE BLINDER STILL HOLDS OPEN ALIGNMENT. (ALSO ENSURE THE LEFT BLINDER BLADE DOES NOT HIT THE WIRE FORM UNDER THE ARCH (See Figure 2)). IF NOT ALIGNED CORRECTLY OR IT HITS THE WIRE FORM, ADJUST THE YELLOW POT R2 (See Figures 2 & 4).
- F. RELEASE START BUTTON. THE BLINDERS WILL CLOSE. AT THIS POINT, ENSURE BLINDER CLOSURE DOES NOT PROTRUDE MORE THAN 3/16" BEYOND ARCH WALL (See Fig. 1) PROCEED TO STEP 4.

4. ADJUST SERVO MOTOR VIA SERVO INTERFACE BOARD--BLINDER CLOSURE ALIGNMENT.

- A. RELEASE START BUTTON. THE BLINDERS WILL CLOSE. AT THIS POINT, ENSURE BLINDER CLOSES AND DOES NOT PROTRUDE MORE THAN 3/16" BEYOND ARCH WALL (See Fig. 1).
- B. TURN RED POT (See Figure 4) TO ADJUST THE CLOSURE SO THE BOTTOM BLINDER DOES NOT EXTEND PAST THE RIGHT STEEL FLAT RAIL. (See Figure 1). LINK ARM SHOULD NOT HAVE ANY TWISTING OR FLEXING WHEN IN THE CLOSED POSITION. IF THIS OCCURS, RELIEVE STRESS BY TURNING THE RED POT R5 (See Figure 4), HOWEVER, ENSURE THE CLOSURE ALIGNMENT STILL REMAINS.
- C. PRESS AND HOLD START BUTTON TO ENSURE OPEN (CENTERING) ALIGNMENT REMAINS THE SAME. (IF NOT, REPEAT STEP 4.)
- D. RELEASE START BUTTON. BLINDERS WILL NOW CLOSE. ENSURE CLOSURE ALIGNMENT STILL REMAINS THE SAME. (IF NOT, REPEAT STEP 3.)

NOTE 1: Alignment adjustments may overlap. Steps 3 & 4 may have to be repeated until desired adjustments are achieved. Adjustments to the red & yellow pots should not require much movements.

5. REINSTALL BOTTOM ARCH.

NOTE 2: If re-alignment is necessary after the Bottom Arch has been re-attached to the playfield, simply remove the Instruction Card and use the Upper Left Corner Cut-Out (See Figure 2, "Service Hole to Servo Board") as an access hole to the Servo Board. Insert the nylon screwdriver for pot R2 or pot R5 adjustment(s). A flashlight may be required.

Figure 1

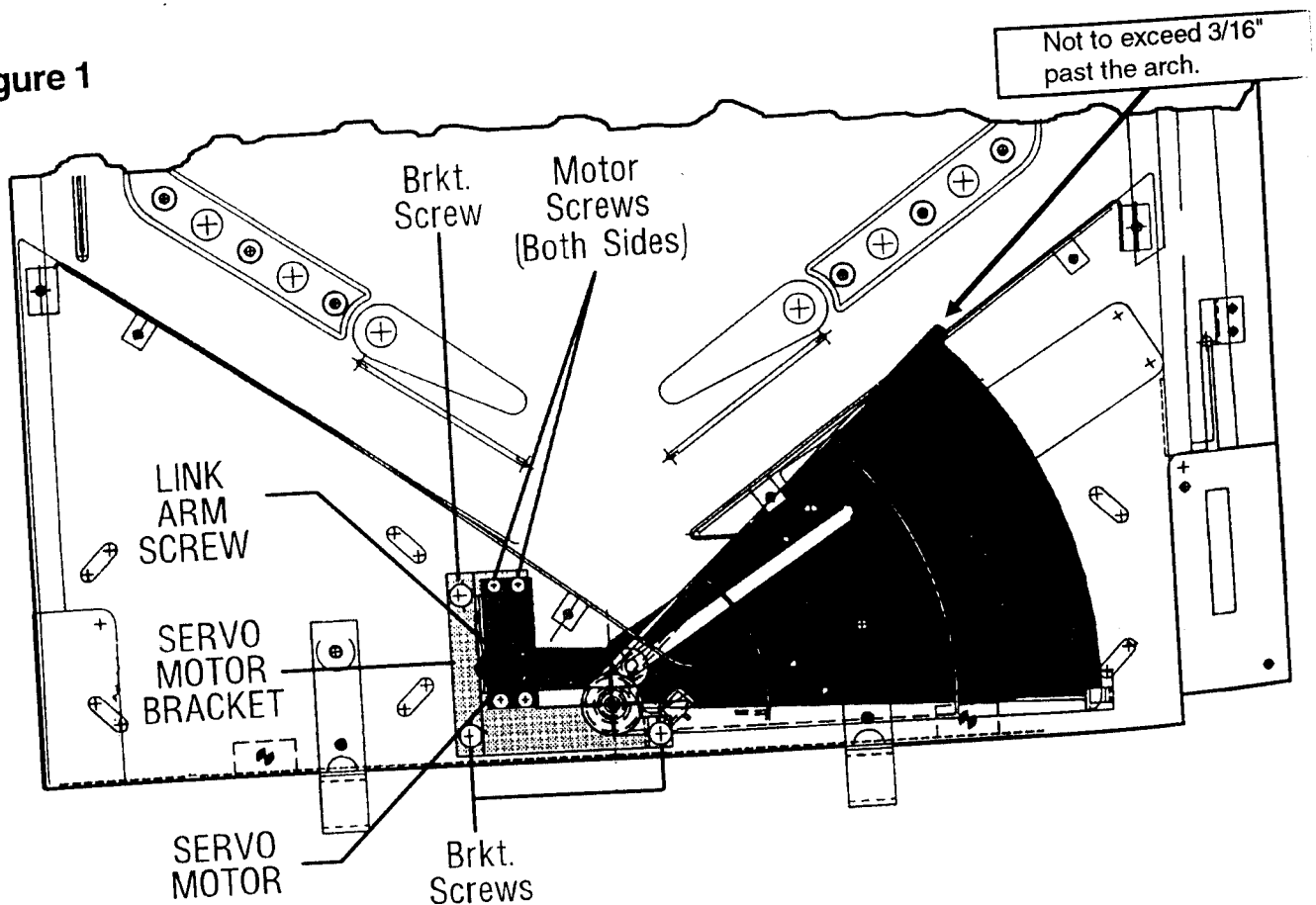

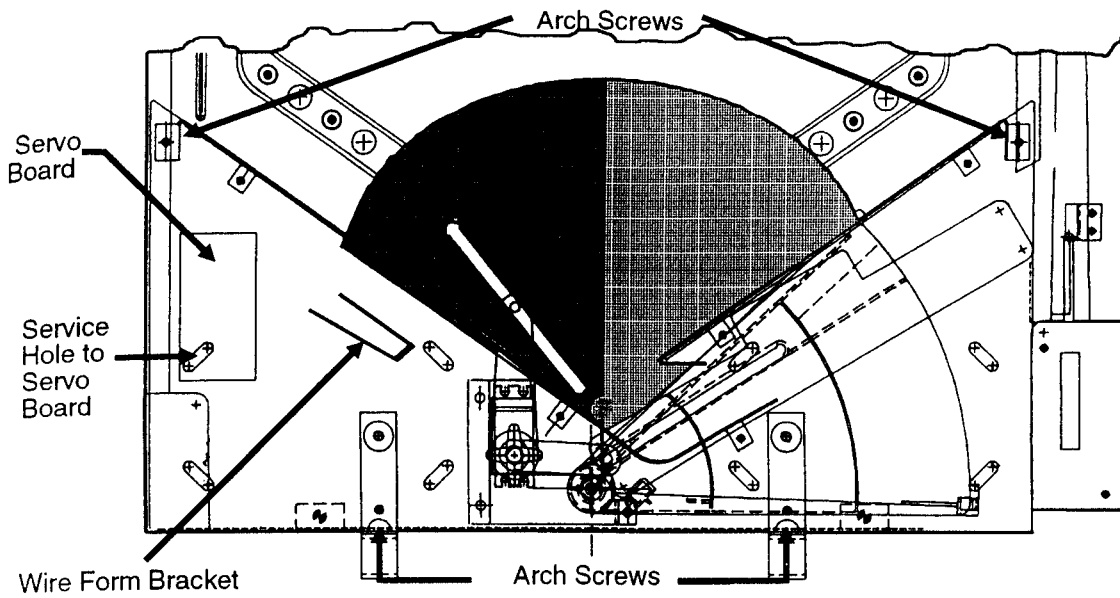

Figure 2

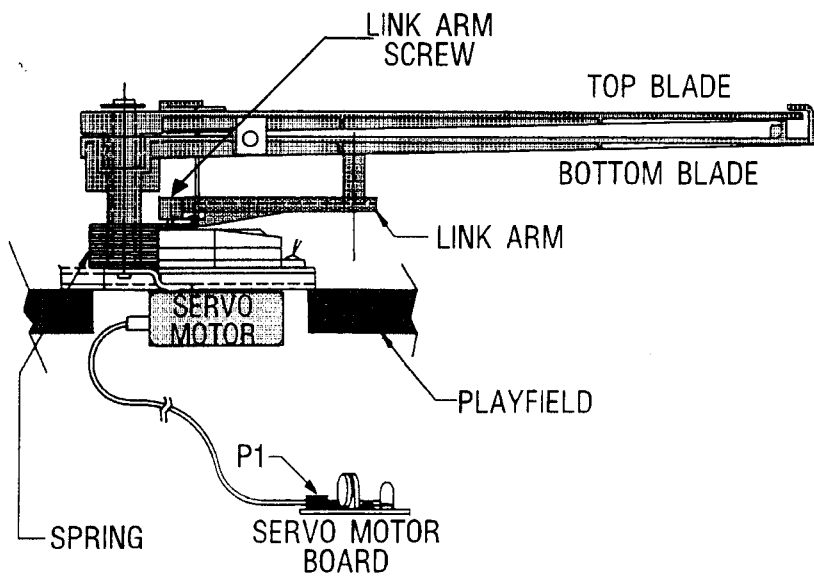

Figure 3

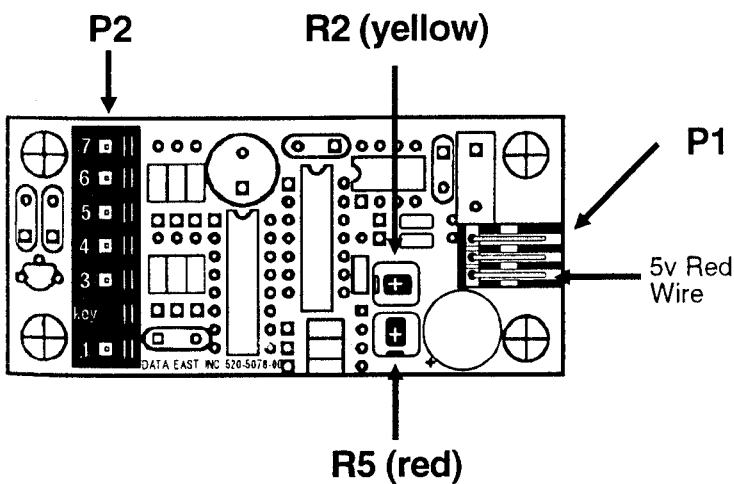

Figure 4

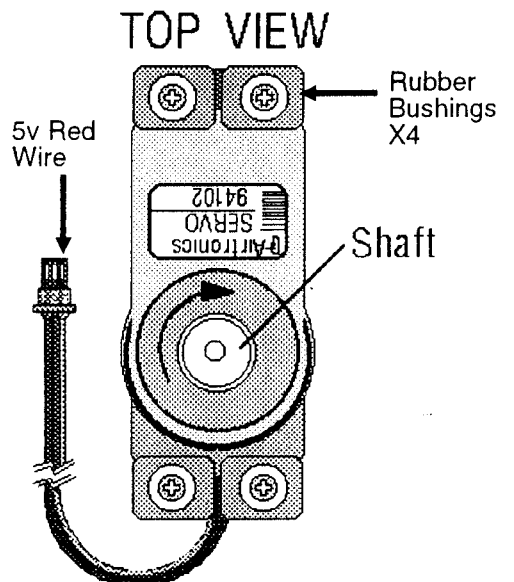

Figure 5